

# SDH Telecommunications Standard Primer

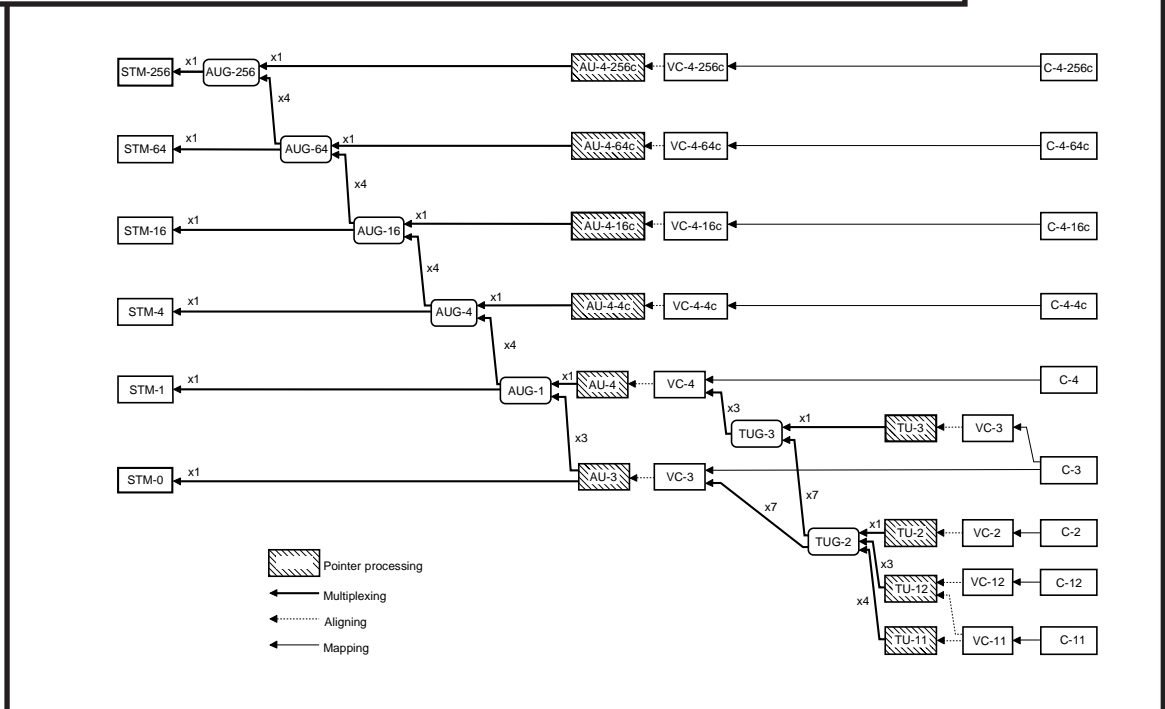

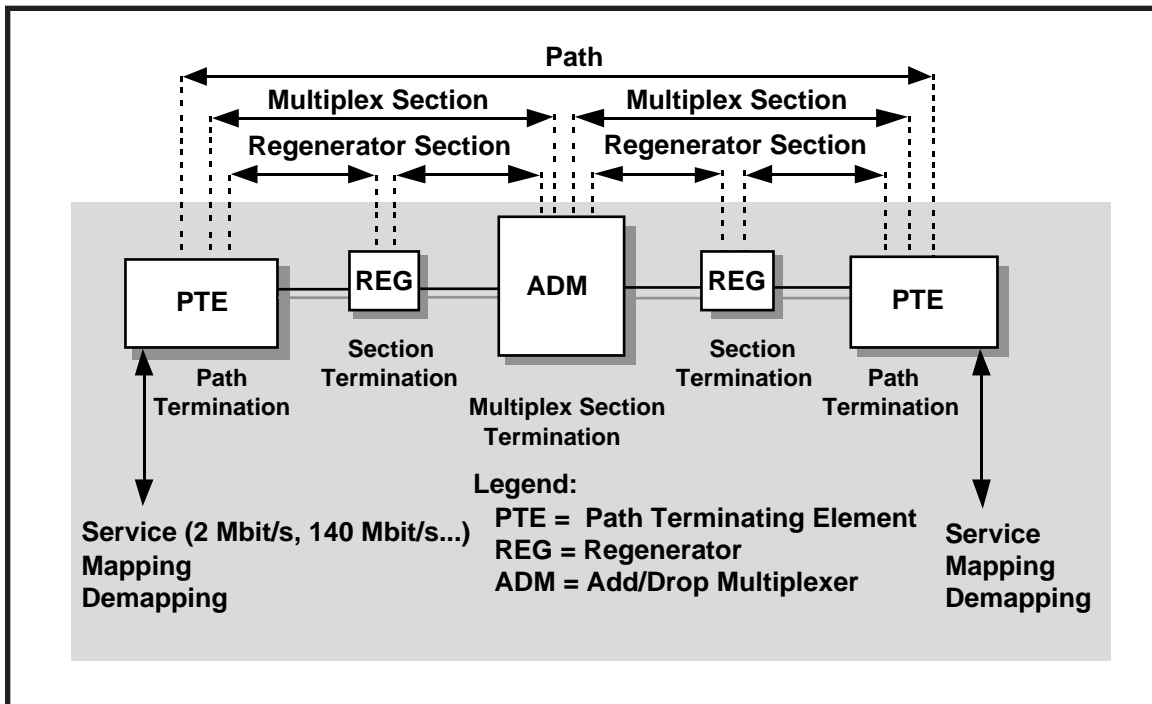

# **SDH**

## **Telecommunications**

### **Standard**

#### **Primer**

---

## **What is SDH?**

This document is intended as an introductory guide to the Synchronous Digital Hierarchy (SDH) multiplexing standard. Standards in the telecommunications field are always evolving. Information in this SDH primer is based on the latest information available from the ITU-T standardisation organization.

Use this primer as an introduction to the technology of SDH. Consult the actual material from ITU-T, paying particular attention to the latest revision, if more detailed information is required.

For help in understanding the language of SDH telecommunications, a comprehensive Glossary appears at the end of this document.



---

# SDH Telecommunications Standard Primer

## Contents

<b>What is SDH?</b> .....	<b>i</b>
<b>Introduction To SDH</b> .....	<b>1</b>
Background .....	1
Synchronisation of Digital Signals .....	1
SDH Advantages .....	1
Plesiochronous Digital Hierarchy (PDH) .....	2
Limitations of PDH Network .....	2
Basic SDH Signal .....	2
Transmission Hierarchies .....	3
<b>Introduction to Synchronisation</b> .....	<b>4</b>
Synchronous versus Asynchronous .....	4
Synchronisation Hierarchy .....	4
Synchronising SDH .....	4
Evolution of Timing and Synchronisation .....	4
<b>SDH Frame Structure</b> .....	<b>5</b>
Virtual Container .....	5
<b>SDH Overhead</b> .....	<b>6</b>
Regenerator Section Overhead .....	6
Multiplex Section Overhead .....	7
Higher-Order Path Overhead (VC-4/VC-3) .....	9
Lower-Order Path Overhead (VC-2/VC-1) .....	12
<b>SDH Anomalies, Defects, Failures, and Alarms</b> .....	<b>15</b>
Definitions .....	15
SDH Error Performance Monitoring .....	15
<b>SDH Pointers</b> .....	<b>17</b>
Payload Pointers .....	17
Positive Pointer Justification .....	17
Negative Pointer Justification .....	18
<b>SDH Multiplexing</b> .....	<b>19</b>
<b>SDH Tributary Multiplexing</b> .....	<b>21</b>
Tributary Unit Group .....	21
TU Multiframe .....	21
TU Payload Pointer .....	22
<b>Automatic Protection Switching</b> .....	<b>23</b>
Multiplex Section Protection, K1/K2 Bytes .....	23
1+1 Protection .....	23
1:N Protection .....	24

<b>SDH Network Elements</b> .....	<b>25</b>
Terminal Multiplexer .....	25
Regenerator .....	25
Add/Drop Multiplexer .....	25
Wideband Digital Cross-connect .....	26
Broadband Digital Cross-connect .....	26
Flexible Multiplexer .....	26
<b>SDH Network Configurations</b> .....	<b>27</b>
Point-to-Point .....	27
Point-to-Multipoint .....	27
Mesh Architecture .....	27
Ring Architecture .....	28
<b>Benefits of SDH – Conclusions</b> .....	<b>29</b>
Pointers, MUX/DEMUX .....	29
Reduced Back-to-Back Multiplexing .....	29
Optical Interconnect .....	29
Multi-point Configurations .....	29
Grooming .....	29
Enhanced OAM .....	29
Enhanced Performance Monitoring .....	29
Convergence, ATM, Video, and SDH .....	29
<b>SONET Reference</b> .....	<b>31</b>
SONET and SDH Hierarchies .....	31
Further Information .....	31
<b>Glossary</b> .....	<b>33</b>
<b>SDH Reference Materials</b> .....	<b>39</b>
ITU-T: .....	39

# Introduction To SDH

SDH (Synchronous Digital Hierarchy) is a standard for telecommunications transport formulated by the International Telecommunication Union (ITU), previously called the International Telegraph and Telephone Consultative Committee (CCITT).

SDH was first introduced into the telecommunications network in 1992 and has been deployed at rapid rates since then. It's deployed at all levels of the network infrastructure, including the access network and the long-distance trunk network. It's based on overlaying a synchronous multiplexed signal onto a light stream transmitted over fibre-optic cable. SDH is also defined for use on radio relay links, satellite links, and at electrical interfaces between equipment.

The comprehensive SDH standard is expected to provide the transport infrastructure for worldwide telecommunications for at least the next two or three decades.

The increased configuration flexibility and bandwidth availability of SDH provides significant advantages over the older telecommunications system. These advantages include:

- A reduction in the amount of equipment and an increase in network reliability.
- The provision of overhead and payload bytes – the overhead bytes permitting management of the payload bytes on an individual basis and facilitating centralised fault sectionalisation.
- The definition of a synchronous multiplexing format for carrying lower-level digital signals (such as 2 Mbit/s, 34 Mbit/s, 140 Mbit/s) which greatly simplifies the interface to

digital switches, digital cross-connects, and add-drop multiplexers.

- The availability of a set of generic standards, which enable multi-vendor interoperability.
- The definition of a flexible architecture capable of accommodating future applications, with a variety of transmission rates.

In brief, SDH defines synchronous transport modules (STMs) for the fibre-optic based transmission hierarchy.

## Background

Before SDH, the first generations of fibre-optic systems in the public telephone network used proprietary architectures, equipment line codes, multiplexing formats, and maintenance procedures. The users of this equipment wanted standards so they could mix and match equipment from different suppliers.

The task of creating such a standard was taken up in 1984 by the Exchange Carriers Standards Association (ECSA) in the U.S. to establish a standard for connecting one fibre system to another. In the late stages of the development, the CCITT became involved so that a single international standard might be developed for fibre interconnect between telephone networks of different countries. The resulting international standard is known as Synchronous Digital Hierarchy (SDH).

## Synchronisation of Digital Signals

To correctly understand the concepts and details of SDH, it's important to be clear about the meaning of Synchronous, Plesiochronous, and Asynchronous.

In a set of **Synchronous** signals, the digital transitions

in the signals occur at exactly the same rate. There may however be a phase difference between the transitions of the two signals, and this would lie within specified limits. These phase differences may be due to propagation time delays, or low-frequency wander introduced in the transmission network. In a synchronous network, all the clocks are traceable to one Stratum 1 Primary Reference Clock (PRC). The accuracy of the PRC is better than  $\pm 1$  in  $10^{11}$  and is derived from a cesium atomic standard.

If two digital signals are **Plesiochronous**, their transitions occur at "almost" the same rate, with any variation being constrained within tight limits. These limits are set down in ITU-T recommendation G.811. For example, if two networks need to interwork, their clocks may be derived from two different PRCs. Although these clocks are extremely accurate, there's a small frequency difference between one clock and the other. This is known as a plesiochronous difference.

In the case of **Asynchronous** signals, the transitions of the signals don't necessarily occur at the same nominal rate. Asynchronous, in this case, means that the difference between two clocks is much greater than a plesiochronous difference. For example, if two clocks are derived from free-running quartz oscillators, they could be described as asynchronous.

## SDH Advantages

The primary reason for the creation of SDH was to provide a long-term solution for an optical mid-span meet between operators; that is, to allow equipment from different vendors to communicate with each other. This ability is referred to as multi-vendor interworking and

allows one SDH-compatible network element to communicate with another, and to replace several network elements, which may have previously existed solely for interface purposes.

The second major advantage of SDH is the fact that it's synchronous. Currently, most fibre and multiplex systems are plesiochronous. This means that the timing may vary from equipment to equipment because they are synchronised from different network clocks. In order to multiplex this type of signal, a process known as bit-stuffing is used. Bit-stuffing adds extra bits to bring all input signals up to some common bit-rate, thereby requiring multi-stage multiplexing and demultiplexing. Because SDH is synchronous, it allows single-stage multiplexing and demultiplexing. This single-stage multiplexing eliminates hardware complexity, thus decreasing the cost of equipment while improving signal quality.

In plesiochronous networks, an entire signal had to be demultiplexed in order to access a particular channel; then the non-accessed channels had to be re-multiplexed back together in order to be sent further along the network to their proper destination. In SDH format, only those channels that are required at a particular point are demultiplexed, thereby eliminating the need for back-to-back multiplexing. In other words, SDH makes individual channels "visible" and they can easily be added and dropped.

### Plesiochronous Digital Hierarchy (PDH)

Traditionally, digital transmission systems and hierarchies have been based on multiplexing signals which are plesiochronous (running at almost the same speed). Also, various parts of the world use different hierarchies which lead to problems of international interworking; for example, between those countries using 1.544 Mbit/s

systems (U.S.A. and Japan) and those using the 2.048 Mbit/s system.

To recover a 64 kbit/s channel from a 140 Mbit/s PDH signal, it's necessary to demultiplex the signal all the way down to the 2 Mbit/s level before the location of the 64 kbit/s channel can be identified. PDH requires "steps" (140-34, 34-8, 8-2 demultiplex; 2-8, 8-34, 34-140 multiplex) to drop out or add an individual speech or data channel (see Figure 1). This is due to the bit-stuffing used at each level.

### Limitations of PDH Network

The main limitations of PDH are:

- Inability to identify individual channels in a higher-order bit stream.
- Insufficient capacity for network management;
- Most PDH network management is proprietary.
- There's no standardised definition of PDH bit rates greater than 140 Mbit/s.
- There are different hierarchies in use around the world. Specialized interface equipment is required to interwork the two hierarchies.

### Basic SDH Signal

The basic format of an SDH signal allows it to carry many different services in its Virtual Container (VC) because it is bandwidth-flexible. This capability allows for such things as the transmission of high-speed packet-switched services, ATM, contribution video, and distribution video. However, SDH

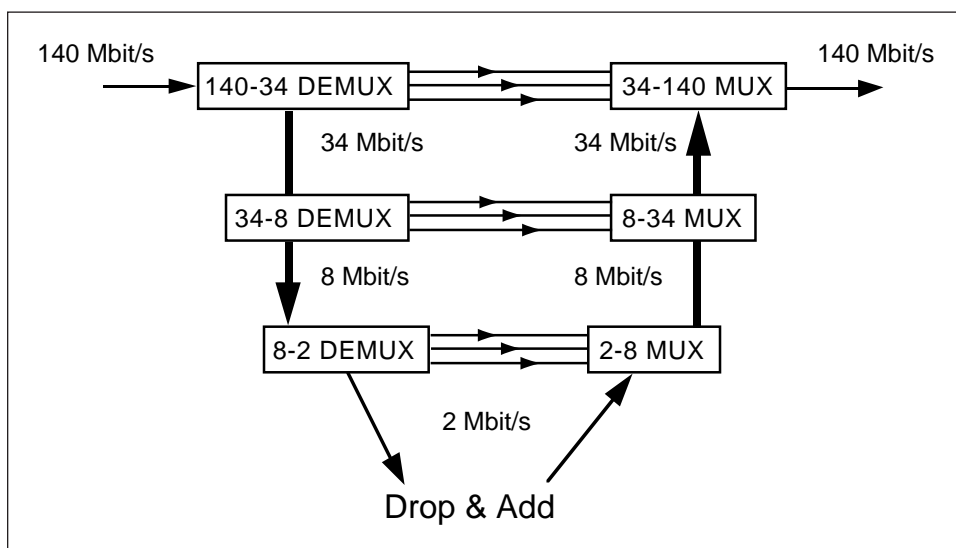

Figure 1. PDH multiplexing by steps, showing add/drop function.



still permits transport and networking at the 2 Mbit/s, 34 Mbit/s, and 140 Mbit/s levels, accommodating the existing digital hierarchy signals. In addition, SDH supports the transport of signals based on the 1.5 Mbit/s hierarchy.

### Transmission Hierarchies

Following ANSI's development of the SONET standard, the ITU-T undertook to define a standard that would address interworking between the 2048 kbit/s and 1554 kbit/s transmission hierarchies. That effort culminated in

1989 with ITU-T's publication of the Synchronous Digital Hierarchy (SDH) standards.

Tables 1 and 2 compare the Non-synchronous and Synchronous transmission hierarchies.

**Table 1. Non-Synchronous, PDH Hierarchy**

Signal	Digital Bit Rate	Channels
<b>E0</b>	64 kbit/s	One 64 kbit/s
<b>E1</b>	2.048 Mbit/s	32 E0
<b>E2</b>	8.448 Mbit/s	128 E0
<b>E3</b>	34.368 Mbit/s	16 E1
<b>E4</b>	139.264 Mbit/s	64 E1

**Table 2. SDH Hierarchy**

Bit Rate	Abbreviated	SDH	SDH Capacity
<b>51.84 Mbit/s</b>	51 Mbit/s	STM-0	21 E1
<b>155.52 Mbit/s</b>	155 Mbit/s	STM-1	63 E1 or 1 E4
<b>622.08 Mbit/s</b>	622 Mbit/s	STM-4	252 E1 or 4 E4
<b>2488.32 Mbit/s</b>	2.4 Gbit/s	STM-16	1008 E1 or 16 E4
<b>9953.28 Mbit/s</b>	10 Gbit/s	STM-64	4032 E1 or 64 E4
<b>39813.12 Mbit/s</b>	40 Gbit/s	STM-256	16128 E1 or 256 E4

STM = Synchronous Transport Module

# Introduction to Synchronisation

## Synchronous versus Asynchronous

Traditionally, transmission systems have been asynchronous, with each terminal in the network running on its own recovered clock timing. In digital transmission, “timing” is one of the most fundamental operations.

Since these clocks are not synchronised, large variations can occur in the clock rate and thus the signal bit rate. For example, an E3 signal specified at 34 Mbit/s  $\pm 20$  ppm (parts per million) can produce a timing difference of up to 1789 bit/s between one incoming E3 signal and another.

Asynchronous multiplexing uses multiple stages. Signals such as asynchronous E1s (2 Mbit/s) are multiplexed (bit-interleaving), extra bits are added (bit-stuffing) to account for the timing variations of each individual stream and are combined with other bits (framing bits) to form an E2 (8 Mbit/s) stream. Bit-interleaving and bit-stuffing is used again to multiplex up to E3 (34 Mbit/s). The E1s are neither visible nor accessible within an E3 frame. E3s are multiplexed up to higher rates in the same manner. At the higher asynchronous rate, they cannot be accessed without demultiplexing.

In a synchronous system, such as SDH, the average frequency of all clocks in the system is the same. Every slave clock can be traced back to a highly stable reference clock. Thus, the STM-1 rate remains at a nominal 155.52 Mbit/s, allowing many synchronous STM-1 signals to be multiplexed without any bit-stuffing. Thus, the STM-1s are easily accessed at a higher STM-N rate.

Low-speed synchronous virtual container (VC) signals are also simple to interleave and transport at higher rates. At low speeds, 2.048 Mbit/s E1 signals are transported within synchronous VC-12 signals which run at a constant rate of 2.304 Mbit/s. Single-step multiplexing up to STM-1 requires no bit-stuffing and VCs are easily accessed.

A mechanism known as “pointers,” operating in conjunction with buffers, accommodates differences in the reference source frequencies and phase wander, and so prevents data loss during synchronisation failures. This is discussed in more detail later in this primer.

## Synchronisation Hierarchy

Digital switches and digital cross-connect systems are commonly employed in the digital network synchronisation hierarchy. The network is organized with a master-slave relationship with clocks of the higher-level nodes feeding timing signals to clocks of the lower-level nodes. All nodes can be traced up to a Primary Reference Clock (PRC).

## Synchronising SDH

The internal clock of an SDH terminal may derive its timing signal from a Synchronisation Supply Unit (SSU) used by switching systems and other equipment. Thus, this terminal can serve as a master for other SDH nodes, providing timing on its outgoing STM-N signal. Other SDH nodes will operate in a slave mode with their internal clocks timed by the incoming STM-N signal. Present standards specify that an SDH network must ultimately be able to derive its timing from a PRC.

## Evolution of Timing and Synchronisation

This is a time of great change for Timing and Synchronisation in the network and there are many challenges for operators and suppliers – and many issues to resolve:

- Synchronisation networks are changing with the introduction of SDH; the historical PDH-based sync network will be replaced by an SDH-based architecture.
- New equipment, network timing, and sync standards have been developed (Tektronix is contributing expertise at ITU and ETSI).
- Transport networks are evolving and hybrid SDH/PDH has specific problems due to the quantisation of network phase variation as pointer justifications.
- New services such as video and ATM depend on excellent timing and network sync to deliver good Quality of Service.
- Jitter/Wander measurement technology is changing from analogue to digital, leading to dramatically new instrument capabilities.
- New test equipment standards are being developed (Tektronix is taking a leading role at ITU).

These and many other timing and sync issues are addressed in another publication from Tektronix: ***Performance Assessment of Timing and Synchronisation in Broadband Networks***.

Copies can be requested from Tektronix offices around the world, or by e-mail at: [timingsync@tek.com](mailto:timingsync@tek.com).

# SDH Frame Structure

The STM-1 frame is the basic transmission format for SDH. The frame lasts for 125 microseconds, therefore, there are 8000 frames per second.

The STM-1 frame consists of overhead plus a virtual container capacity (see Figure 2). The first nine columns of

each frame make up the Section Overhead, and the last 261 columns make up the Virtual Container (VC) capacity. The VC plus the pointers (H1, H2, H3 bytes) is called the AU (Administrative Unit).

Carried within the VC capacity, which has its own frame structure of nine rows and 261 columns, is the Path Overhead and the Container (see Figure 3). The first column is for Path Overhead; it's followed by the payload container, which can itself carry other containers.

Virtual Containers can have any phase alignment within

the Administrative Unit, and this alignment is indicated by the Pointer in row four, as described later in the Pointers section. Within the Section Overhead, the first three rows are used for the Regenerator Section Overhead, and the last five rows are used for the Multiplex Section Overhead.

The STM frame is transmitted in a byte-serial fashion, row-by-row, and is scrambled immediately prior to transmission to ensure adequate clock timing content for downstream regenerators.

## Virtual Container

SDH supports a concept called virtual containers (VC). Through the use of pointers and offset values, VCs can be carried in the SDH payload as independent data packages. VCs are used to transport lower-speed tributary signals. Figure 3 illustrates the location of a VC-4 within the STM-1 frame.

Note that it can start (indicated by the J1 path overhead byte) at any point within the STM-1 frame. The start location of the J1 byte is indicated by the pointer byte values.

Virtual containers can also be concatenated to provide more capacity in a flexible fashion.

Table 3 lists the names and some of the parameters of the virtual containers.

**Table 3. Virtual Containers (VC)**

SDH	Digital Bit Rate	Size of VC
VC-11	1.728 Mbit/s	9 rows, 3 columns
VC-12	2.304 Mbit/s	9 rows, 4 columns
VC-2	6.912 Mbit/s	9 rows, 12 columns
VC-3	48.960 Mbit/s	9 rows, 85 columns
VC-4	150.336 Mbit/s	9 rows, 261 columns

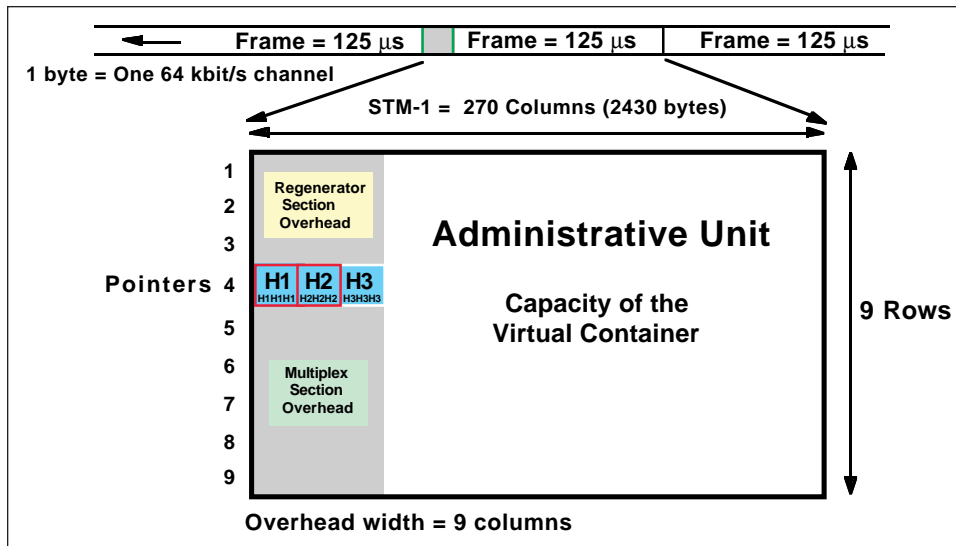

Figure 2. STM-1 frame structure.

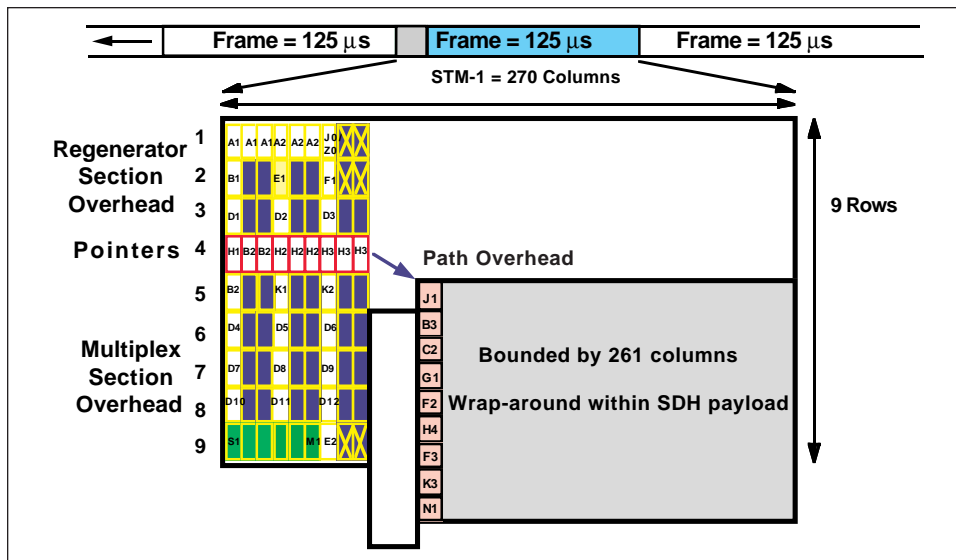

Figure 3. Virtual container structure showing VC-4.

# SDH Overhead

The SDH standard was developed using a client/server layer approach (see Figure 4). The overhead and transport functions are divided into layers. They are:

- Regenerator Section
- Multiplex Section
- Path

The layers have a hierarchical relationship, with each layer building on the services provided by all the lower layers.

This section details the different SDH overhead information, specifically:

- Regenerator Section Overhead
- Multiplex Overhead
- Path Overhead

## Regenerator Section Overhead

The Regenerator Section Overhead contains only the information required for the elements located at both ends of a section. This might be

two regenerators, a piece of line terminating equipment and a regenerator, or two pieces of line terminating equipment.

The Regenerator Section Overhead is found in the first three rows of Columns 1 through 9 of the STM-1 frame (see Figure 5). Byte by byte, the Regenerator Section Overhead is shown in Table 4.

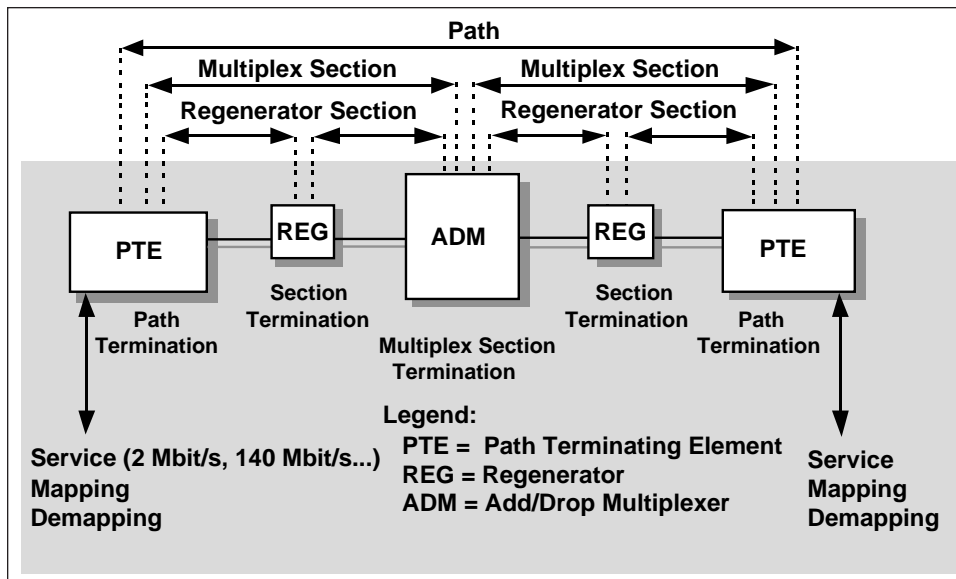

Figure 4. SDH network layers.

Regenerator Section	STM-1								
1	A1	A1	A1	A2	A2	A2	J0		
2	B1	△	△	E1	△		F1		
3	D1	△	△	D2	△		D3		
4	H1	H1	H1	H2	H2	H2	H3	H3	H3
5	B2	B2	B2	K1			K2		
6	D4			D5			D6		
7	D6			D8			D9		
8	D10			D11			D12		
9	S1					M1	E2		

△ = Media-dependent bytes

Figure 5. STM-1 Regenerator section overhead.

**Table 4. Regenerator Section Overhead**

Byte	Description
A1 and A2	<b>Framing bytes</b> – These two bytes indicate the beginning of the STM-N frame. The A1, A2 bytes are unscrambled. A1 has the binary value 11110110, and A2 has the binary value 00101000. The frame alignment word of an STM-N frame is composed of (3 x N) A1 bytes followed by (3 x N) A2 bytes.
J0	<b>Regenerator Section (RS) Trace message</b> – It's used to transmit a Section Access Point Identifier so that a section receiver can verify its continued connection to the intended transmitter. The coding of the J0 byte is the same as for J1 and J2 bytes. This byte is defined only for STM-1 number 1 of an STM-N signal.
Z0	These bytes, which are located at positions S[1,6N+2] to S[1,7N] of an STM-N signal (N > 1), are reserved for future international standardisation.
B1	<b>RS bit interleaved parity code (BIP-8) byte</b> – This is a parity code (even parity), used to check for transmission errors over a regenerator section. Its value is calculated over all bits of the previous STM-N frame after scrambling, then placed in the B1 byte of STM-1 before scrambling. Therefore, this byte is defined only for STM-1 number 1 of an STM-N signal.
E1	<b>RS orderwire byte</b> – This byte is allocated to be used as a local orderwire channel for voice communication between regenerators.
F1	<b>RS user channel byte</b> – This byte is set aside for the user's purposes; it can be read and/or written to at each section terminating equipment in that line.
D1, D2, D3	<b>RS Data Communications Channel (DCC) bytes</b> – These three bytes form a 192 kbit/s message channel providing a message-based channel for Operations, Administration and Maintenance (OAM) between pieces of section terminating equipment. The channel can be used from a central location for control, monitoring, administration, and other communication needs.

**Multiplex Section Overhead**

The Multiplex Section Overhead contains the information required between the multiplex section termination equipment at each end of the

Multiplex section (that is, between consecutive network elements excluding the regenerators).

The Multiplex Section Overhead is found in Rows 5

to 9 of Columns 1 through 9 of the STM-1 frame (see Figure 6). Byte by byte, the Multiplex Section Overhead is shown in Table 5.

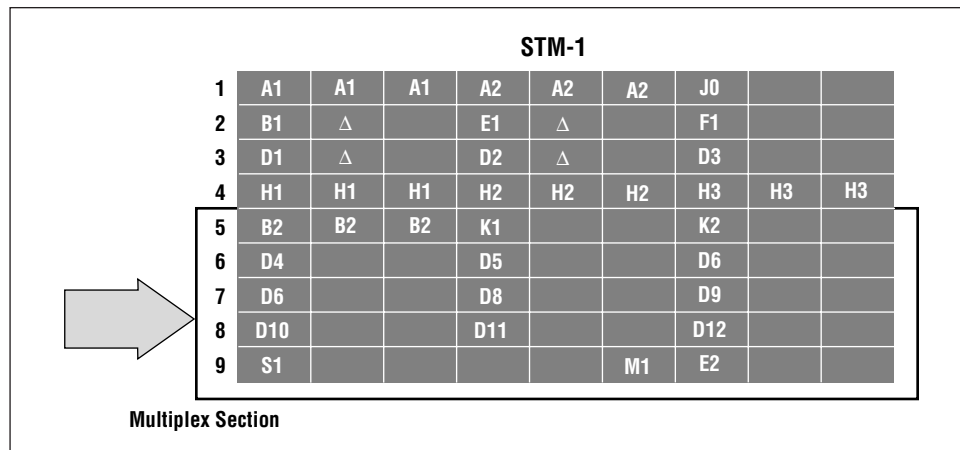

Figure 6. STM-1 Multiplex section overhead.

**Table 5. Multiplex Section Overhead**

Byte	Description
<b>B2</b>	<b>Multiplex Section (MS) bit interleaved parity code (MS BIP-24) byte</b> – This bit interleaved parity N x 24 code is used to determine if a transmission error has occurred over a multiplex section. It's even parity, and is calculated overall bits of the MS Overhead and the STM-N frame of the previous STM-N frame before scrambling. The value is placed in the three B2 bytes of the MS Overhead before scrambling. These bytes are provided for all STM-1 signals in an STM-N signal.
<b>K1 and K2</b>	<b>Automatic Protection Switching (APS channel) bytes</b> – These two bytes are used for MSP (Multiplex Section Protection) signaling between multiplex level entities for bi-directional automatic protection switching and for communicating Alarm Indication Signal (AIS) and Remote Defect Indication (RDI) conditions. The Multiplex Section Remote Defect Indication (MS-RDI) is used to return an indication to the transmit end that the received end has detected an incoming section defect or is receiving MS-AIS. MS-RDI is generated by inserting a "110" code in positions 6, 7, and 8 of the K2 byte before scrambling.
	<u>K1 Byte</u>
	Bits 1-4      Type of request
	1111      Lock out of Protection
	1110      Forced Switch
	1101      Signal Fail – High Priority
	1100      Signal Fail – Low Priority
	1011      Signal Degrade – High Priority
	1010      Signal Degrade – Low Priority
	1001      (not used)
	1000      Manual Switch
	0111      (not used)
	0110      Wait-to-Restore
	0101      (not used)
	0100      Exercise
	0011      (not used)
	0010      Reverse Request
	0001      Do Not Revert
	0000      No Request
	Bits 5-8      Indicate the number of the channel requested
	<u>K2 Byte</u>
	Bits 1-4      Selects channel number
	Bit 5          Indication of architecture
	0          1+1
	1          1:n
	Bits 6-8      Indicate mode of operation
	111      MS-AIS
	110      MS-RDI
	101      Provisioned mode is bi-directional
	100      Provisioned mode is unidirectional
	011      Future use
	010      Future use
	001      Future use
	000      Future use
<b>D4 to D12</b>	<b>MS Data Communications Channel (DCC) bytes</b> – These nine bytes form a 576 kbit/s message channel from a central location for OAM information (control, maintenance, remote provisioning, monitoring, administration and other communication needs).
<b>S1</b>	<b>Synchronisation status message byte (SSMB)</b> – Bits 5 to 8 of this S1 byte are used to carry the synchronisation messages. Following is the assignment of bit patterns to the four synchronisation levels agreed to within ITU-T (other values are reserved):
	<u>Bits 5-8</u>
	0000      Quality unknown (existing sync. network)
	0010      G.811 PRC
	0100      SSU-A (G.812 transit)
	1000      SSU-B (G.812 local)
	1011      G.813 Option 1 Synchronous Equipment Timing Clock (SEC)
	1111      Do not use for synchronisation. This message may be emulated by equipment failures and will be emulated by a Multiplex Section AIS signal.
<b>M1</b>	<b>MS remote error indication</b> – The M1 byte of an STM-1 or the first STM-1 of an STM-N is used for a MS layer remote error indication (MS-REI). Bits 2 to 8 of the M1 byte are used to carry the error count of the interleaved bit blocks that the MS BIP-24xN has detected to be in error at the far end of the section. This value is truncated at 255 for STM-N >4.
<b>E2</b>	<b>MS orderwire byte</b> – This orderwire byte provides a 64 kbit/s channel between multiplex entities for an express orderwire. It's a voice channel for use by craftspersons and can be accessed at multiplex section terminations.

**Higher-Order Path Overhead (VC-4/VC-3)**

The Path Overhead is assigned to, and transported with the Virtual Container from the time it's created by

path terminating equipment until the payload is demultiplexed at the termination point in a piece of path terminating equipment.

The Path Overhead is found in Rows 1 to 9 of the first column of the VC-4 or VC-3 (see Figure 7). Byte by byte, the Higher Order Path Overhead is shown in Table 6.

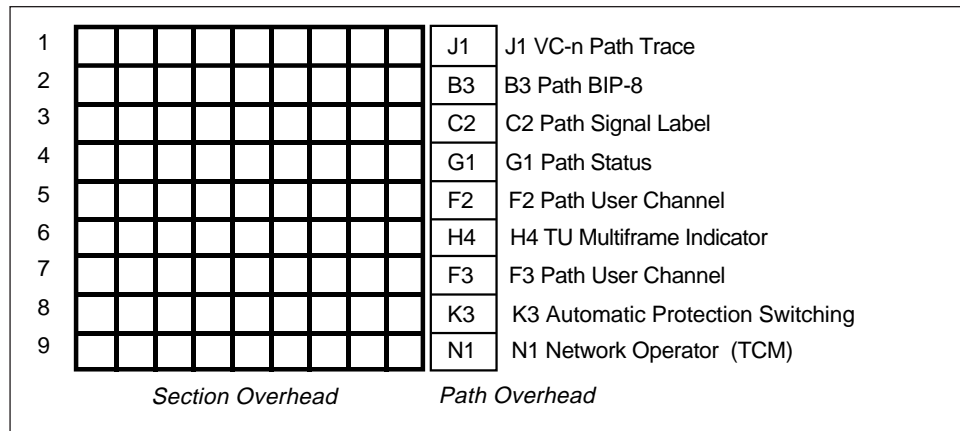

Figure 7. Higher-order path overhead (VC-4/VC-3).

**Table 6. Higher-Order Path Overhead**

Byte	Description																																																																																								
<b>J1</b>	<b>Higher-Order VC-N path trace byte</b> – This user-programmable byte repetitively transmits a 15-byte, E.64 format string plus 1-byte CRC-7. A 64-byte free-format string is also permitted for this Access Point Identifier. This allows the receiving terminal in a path to verify its continued connection to the intended transmitting terminal.																																																																																								
<b>B3</b>	<b>Path bit interleaved parity code (Path BIP-8) byte</b> – This is a parity code (even), used to determine if a transmission error has occurred over a path. Its value is calculated over all the bits of the previous virtual container before scrambling and placed in the B3 byte of the current frame.																																																																																								
<b>C2</b>	<b>Path signal label byte</b> – This byte specifies the mapping type in the VC-N. Standard binary values for C2 are:																																																																																								
	<table border="1"> <thead> <tr> <th>MSB</th> <th>LSB</th> <th>Hex Code</th> <th>Interpretation</th> </tr> </thead> <tbody> <tr> <td>Bits 1-4</td> <td>Bits 5-8</td> <td></td> <td></td> </tr> <tr> <td>0000</td> <td>0000</td> <td>00</td> <td>Unequipped or supervisory-unequipped</td> </tr> <tr> <td>0000</td> <td>0001</td> <td>01</td> <td>Equipped – non-specific</td> </tr> <tr> <td>0000</td> <td>0010</td> <td>02</td> <td>TUG structure</td> </tr> <tr> <td>0000</td> <td>0011</td> <td>03</td> <td>Locked TU-n</td> </tr> <tr> <td>0000</td> <td>0100</td> <td>04</td> <td>Asynchronous mapping of 34,368 kbit/s or 44,736 kbit/s into the Container-3</td> </tr> <tr> <td>0001</td> <td>0010</td> <td>12</td> <td>Asynchronous mapping of 139,264 kbit/s into the Container-4</td> </tr> <tr> <td>0001</td> <td>0011</td> <td>13</td> <td>ATM mapping</td> </tr> <tr> <td>0001</td> <td>0100</td> <td>14</td> <td>MAN DQDB (IEEE Standard 802.6) mapping</td> </tr> <tr> <td>0001</td> <td>0101</td> <td>15</td> <td>FDDI (ISO Standard 9314) mapping</td> </tr> <tr> <td>0001</td> <td>0110</td> <td>16</td> <td>Mapping of HDLC/PPP (Internet Standard 51) framed signal</td> </tr> <tr> <td>0001</td> <td>0111</td> <td>17</td> <td>Mapping of Simple Data Link (SDL) with SDH self synchronising scrambler</td> </tr> <tr> <td>0001</td> <td>1000</td> <td>18</td> <td>Mapping of HDLC/LAP-S framed signals</td> </tr> <tr> <td>0001</td> <td>1001</td> <td>19</td> <td>Mapping of Simple Data Link (SDL) with set-reset scrambler</td> </tr> <tr> <td>0001</td> <td>1010</td> <td>1A</td> <td>Mapping of 10 Gbit/s Ethernet frames (IEEE 802.3)</td> </tr> <tr> <td>1100</td> <td>1111</td> <td>CF</td> <td>Obsolete mapping of HDLC/PPP framed signal</td> </tr> <tr> <td>1110</td> <td>0001</td> <td>E1</td> <td>Reserved for national use</td> </tr> <tr> <td>.</td> <td>.</td> <td>.</td> <td>.</td> </tr> <tr> <td>1111</td> <td>1100</td> <td>FC</td> <td>Reserved for national use</td> </tr> <tr> <td>1111</td> <td>1110</td> <td>FE</td> <td>Test signal, O.181 specific mapping</td> </tr> <tr> <td>1111</td> <td>1111</td> <td>FF</td> <td>VC-AIS</td> </tr> </tbody> </table>	MSB	LSB	Hex Code	Interpretation	Bits 1-4	Bits 5-8			0000	0000	00	Unequipped or supervisory-unequipped	0000	0001	01	Equipped – non-specific	0000	0010	02	TUG structure	0000	0011	03	Locked TU-n	0000	0100	04	Asynchronous mapping of 34,368 kbit/s or 44,736 kbit/s into the Container-3	0001	0010	12	Asynchronous mapping of 139,264 kbit/s into the Container-4	0001	0011	13	ATM mapping	0001	0100	14	MAN DQDB (IEEE Standard 802.6) mapping	0001	0101	15	FDDI (ISO Standard 9314) mapping	0001	0110	16	Mapping of HDLC/PPP (Internet Standard 51) framed signal	0001	0111	17	Mapping of Simple Data Link (SDL) with SDH self synchronising scrambler	0001	1000	18	Mapping of HDLC/LAP-S framed signals	0001	1001	19	Mapping of Simple Data Link (SDL) with set-reset scrambler	0001	1010	1A	Mapping of 10 Gbit/s Ethernet frames (IEEE 802.3)	1100	1111	CF	Obsolete mapping of HDLC/PPP framed signal	1110	0001	E1	Reserved for national use	.	.	.	.	1111	1100	FC	Reserved for national use	1111	1110	FE	Test signal, O.181 specific mapping	1111	1111	FF	VC-AIS
MSB	LSB	Hex Code	Interpretation																																																																																						
Bits 1-4	Bits 5-8																																																																																								
0000	0000	00	Unequipped or supervisory-unequipped																																																																																						
0000	0001	01	Equipped – non-specific																																																																																						
0000	0010	02	TUG structure																																																																																						
0000	0011	03	Locked TU-n																																																																																						
0000	0100	04	Asynchronous mapping of 34,368 kbit/s or 44,736 kbit/s into the Container-3																																																																																						
0001	0010	12	Asynchronous mapping of 139,264 kbit/s into the Container-4																																																																																						
0001	0011	13	ATM mapping																																																																																						
0001	0100	14	MAN DQDB (IEEE Standard 802.6) mapping																																																																																						
0001	0101	15	FDDI (ISO Standard 9314) mapping																																																																																						
0001	0110	16	Mapping of HDLC/PPP (Internet Standard 51) framed signal																																																																																						
0001	0111	17	Mapping of Simple Data Link (SDL) with SDH self synchronising scrambler																																																																																						
0001	1000	18	Mapping of HDLC/LAP-S framed signals																																																																																						
0001	1001	19	Mapping of Simple Data Link (SDL) with set-reset scrambler																																																																																						
0001	1010	1A	Mapping of 10 Gbit/s Ethernet frames (IEEE 802.3)																																																																																						
1100	1111	CF	Obsolete mapping of HDLC/PPP framed signal																																																																																						
1110	0001	E1	Reserved for national use																																																																																						
.	.	.	.																																																																																						
1111	1100	FC	Reserved for national use																																																																																						
1111	1110	FE	Test signal, O.181 specific mapping																																																																																						
1111	1111	FF	VC-AIS																																																																																						

**Table 6 (contd)**

Byte	Description																																																				
<b>G1</b>	<p><b>Path status byte</b> – This byte is used to convey the path terminating status and performance back to the originating path terminating equipment. Therefore the bi-directional path in its entirety can be monitored, from either end of the path.</p> <div style="text-align: center; border: 1px solid black; padding: 5px; margin: 10px 0;"> <table border="1" style="border-collapse: collapse; width: 100%;"> <tr> <td colspan="4" style="text-align: center;">REI</td> <td colspan="2" style="text-align: center;">RDI</td> <td colspan="2" style="text-align: center;">Reserved</td> <td colspan="2" style="text-align: center;">Spare</td> </tr> <tr> <td style="text-align: center;">1</td> <td style="text-align: center;">2</td> <td style="text-align: center;">3</td> <td style="text-align: center;">4</td> <td style="text-align: center;">5</td> <td style="text-align: center;">6</td> <td style="text-align: center;">7</td> <td colspan="2" style="text-align: center;">8</td> </tr> </table> </div> <p>Byte G1 is allocated to convey back to a VC-4-Xc/VC-4/VC-3 trail termination source the status and performance of the complete trail. Bits 5 to 7 may be used to provide an enhanced remote defect indication with additional differentiation between the payload defect (PLM), server defects (AIS, LOP) and connectivity defects (TIM, UNEQ). The following codes are used:</p> <table style="width: 100%; border-collapse: collapse;"> <tr> <td style="width: 10%;">Bits 5-7</td> <td style="width: 50%;">Meaning</td> <td style="width: 40%;">Triggers</td> </tr> <tr> <td>001</td> <td>No remote defect</td> <td>No remote defect</td> </tr> <tr> <td>010</td> <td>E-RDI Payload defect</td> <td>PLM</td> </tr> <tr> <td>101</td> <td>E-RDI Server defect</td> <td>AIS, LOP</td> </tr> <tr> <td>110</td> <td>E-RDI Connectivity defect</td> <td>TIM, UNEQ</td> </tr> </table> <p>The E-RDI G1 (bits 5-7) code interpretation provides for interworking with equipment which supports RDI. It is not necessary for the interpretation to identify if the equipment supports RDI or E-RDI. For the E-RDI codes, bit 7 is set to the inverse of bit 6. Following is the E-RDI G1 (bits 5-7) code interpretation:</p> <table style="width: 100%; border-collapse: collapse;"> <tr> <td style="width: 10%;">Bits 5-7</td> <td style="width: 90%;">E-RDI Interpretation</td> </tr> <tr> <td>000</td> <td>No remote defect (Note 1)</td> </tr> <tr> <td>001</td> <td>No remote defect</td> </tr> <tr> <td>010</td> <td>E-RDI Payload defect (Note 2)</td> </tr> <tr> <td>011</td> <td>No remote defect (Note 1)</td> </tr> <tr> <td>100</td> <td>E-RDI Server defect (Note 1)</td> </tr> <tr> <td>101</td> <td>Remote E-RDI Server defect</td> </tr> <tr> <td>110</td> <td>Remote E-RDI Connectivity defect</td> </tr> <tr> <td>111</td> <td>Remote E-RDI Server Defect (Note 1)</td> </tr> </table> <p>NOTE 1: These codes are generated by RDI supporting equipment and are interpreted by E-RDI supporting equipment as shown. For equipment supporting RDI, clause 9.3.1.4/G.707, this code is triggered by the presence or absence of one of the following defects: AIS, LOP, TIM, or UNEQ. Equipment conforming to an earlier version of this standard may include PLM as a trigger condition. ATM equipment complying with the 1993 version of ITU-T Recommendation I.432 may include LCD as a trigger condition. Note that for some national networks, this code was triggered only by an AIS or LOP defect.</p> <p>NOTE 2: ATM equipment complying with the 08/96 version of ITU-T Recommendation I.432.2 may include LCD as a trigger condition.</p>	REI				RDI		Reserved		Spare		1	2	3	4	5	6	7	8		Bits 5-7	Meaning	Triggers	001	No remote defect	No remote defect	010	E-RDI Payload defect	PLM	101	E-RDI Server defect	AIS, LOP	110	E-RDI Connectivity defect	TIM, UNEQ	Bits 5-7	E-RDI Interpretation	000	No remote defect (Note 1)	001	No remote defect	010	E-RDI Payload defect (Note 2)	011	No remote defect (Note 1)	100	E-RDI Server defect (Note 1)	101	Remote E-RDI Server defect	110	Remote E-RDI Connectivity defect	111	Remote E-RDI Server Defect (Note 1)
REI				RDI		Reserved		Spare																																													
1	2	3	4	5	6	7	8																																														
Bits 5-7	Meaning	Triggers																																																			
001	No remote defect	No remote defect																																																			
010	E-RDI Payload defect	PLM																																																			
101	E-RDI Server defect	AIS, LOP																																																			
110	E-RDI Connectivity defect	TIM, UNEQ																																																			
Bits 5-7	E-RDI Interpretation																																																				
000	No remote defect (Note 1)																																																				
001	No remote defect																																																				
010	E-RDI Payload defect (Note 2)																																																				
011	No remote defect (Note 1)																																																				
100	E-RDI Server defect (Note 1)																																																				
101	Remote E-RDI Server defect																																																				
110	Remote E-RDI Connectivity defect																																																				
111	Remote E-RDI Server Defect (Note 1)																																																				
<b>F2</b>	<b>Path user channel byte</b> – This byte is used for user communication between path elements.																																																				
<b>H4</b>	<b>Position and Sequence Indicator byte</b> – This byte provides a multi frame and sequence indicator for virtual VC-3/4 concatenation and a generalized position indicator for payloads. In the latter case, the content is payload specific (e.g., H4 can be used as a multiframe indicator for VC-2/1 payload). For mapping of DQDB in VC-4, the H4 byte carries the slot boundary information and the Link Status Signal (LSS). Bits 1-2 are used for the LSS code as described in IEEE Standard 802.6. Bits 3-8 form the slot offset indicator. The slot offset indicator contains a binary number indicating the offset in octets between the H4 octet and the first slot boundary following the H4 octet. The valid range of the slot offset indicator value is 0 to 52. A received value of 53 to 63 corresponds to an error condition.																																																				
<b>F3</b>	<b>Path user channel byte</b> – This byte is allocated for communication purposes between path elements and is payload dependent.																																																				
<b>K3</b>	<b>APS signalling</b> is provided in K3 bits 1-4, allocated for protection at the VC-4/3 path levels. K3 bits 5-8 are allocated for future use. These bits have no defined value. The receiver is required to ignore their content.																																																				



**Table 6 (contd)**

Byte	Description
------	-------------

**N1** **Network operator byte** – This byte is allocated to provide a Higher-Order Tandem Connection Monitoring (HO-TCM) function. N1 is allocated for Tandem Connection Monitoring for contiguous concatenated VC-4, the VC-4 and VC-3 levels.

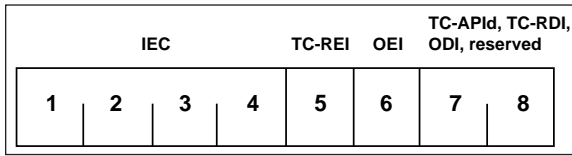

Bits 1-4	Incoming Error Count (IEC).
1001	0
0001	1
0010	2
0011	3
0100	4
0101	5
0110	6
0111	7
1000	8
1110	Incoming AIS

NOTE: To guarantee a non all-zeroes N1 byte independent of the incoming signal status, it is required that the IEC code field contains at least one “1”. When zero errors in the BIP-8 of the incoming signal are detected, an IEC code is inserted with “1”s in it. In this manner, it is possible for the Tandem Connection sink at the tail end of the Tandem Connection link to use the IEC code field to distinguish between unequipped conditions started within or before the Tandem Connection.

Bit 5 Operates as the TC-REI of the Tandem Connection to indicate errored blocks caused within the Tandem Connection.

Bit 6 Operates as the OEI to indicate errored blocks of the egressing VC-n.

Bits 7-8 Operate in a 76 multiframe as:

- Access point identifier of the Tandem Connection (TC-APId); it complies with the generic 16-byte string format given in 9.2.2.2.
- TC-RDI, indicating to the far end that defects have been detected within the Tandem Connection at the near end Tandem Connection sink.
- ODI, indicating to the far end that AU/TU-AIS has been inserted into the egressing AU-n/TU-n at the TC-sink due to defects before or within the Tandem Connection.
- Reserved capacity (for future standardization).

Frame #	Bits 7-8 definition
1-8	Frame Alignment Signal: 1111 1111 1111 1110
9-12	TC-APId byte #1 [ 1 C <sub>1</sub> C <sub>2</sub> C <sub>3</sub> C <sub>4</sub> C <sub>5</sub> C <sub>6</sub> C <sub>7</sub> ]
13-16	TC-APId byte #2 [ 0 X X X X X X X ]
17-20	TC-APId byte #3 [ 0 X X X X X X X ]
:	:
65-68	TC-APId byte #15 [ 0 X X X X X X X ]
69-72	TC-APId byte #16 [ 0 X X X X X X X ]
73-76	TC-RDI, ODI and Reserved (see following)

Frame #	Bit 7 definition	Bit 8 definition
73	Reserved (default = “0”)	TC-RDI
74	ODI	Reserved (default = “0”)
75	Reserved (default = “0”)	Reserved (default = “0”)
76	Reserved (default = “0”)	Reserved (default = “0”)

**Lower-Order Path Overhead (VC-2/VC-1)**

The bytes V5, J2, N2, and K4 are allocated to the VC-2/VC-1 POH. The V5 byte is the first

byte of the multiframe and its position is indicated by the TU-2/TU-1 pointer. The V5 byte provides the functions of error checking, signal label, and path status of the

VC-2/VC-1 paths. The bit assignments for the V5 byte and the byte-by-byte Lower Order Path Overhead is shown in Table 7.

**Table 7. Lower-Order Path Overhead**

Byte	Description																								
<b>V5</b>	<b>VT path overhead byte.</b>																								
	<table border="1" style="margin-left: 40px;"> <thead> <tr> <th colspan="2">BIP-2</th> <th>REI</th> <th>RFI</th> <th colspan="3">Signal Label</th> <th>RDI</th> </tr> <tr> <th>1</th> <th>2</th> <th>3</th> <th>4</th> <th>5</th> <th>6</th> <th>7</th> <th>8</th> </tr> </thead> <tbody> <tr> <td style="width: 15px;"> </td> <td style="width: 15px;"> </td> <td style="width: 15px;"> </td> <td style="width: 15px;"> </td> <td style="width: 15px;"> </td> <td style="width: 15px;"> </td> <td style="width: 15px;"> </td> <td style="width: 15px;"> </td> </tr> </tbody> </table>	BIP-2		REI	RFI	Signal Label			RDI	1	2	3	4	5	6	7	8								
BIP-2		REI	RFI	Signal Label			RDI																		
1	2	3	4	5	6	7	8																		
Bits 1-2	Allocated for error performance monitoring. A Bit Interleaved Parity (BIP-2) scheme is specified. Includes POH bytes, but excludes V1, V2, V3, and V4.																								
Bit 3	A VC-2/VC-1 path Remote Error Indication (LP-REI) that is set to one and sent back towards a VC-2/VC-1 path originator if one or more errors were detected by the BIP-2; otherwise set to zero.																								
Bit 4	A VC-2/VC-1 path Remote Failure Indication (LP-RFI). This bit is set to one if a failure is declared, otherwise it is set to zero. A failure is a defect that persists beyond the maximum time allocated to the transmission system protection mechanisms.																								
Bits 5-7	Provide a VC-2/VC-1 signal label. The Virtual Container path Signal Label coding is:																								
000	Unequipped or supervisory-unequipped																								
001	Equipped – non-specific																								
010	Asynchronous																								
011	Bit synchronous																								
100	Byte synchronous																								
101	Reserved for future use																								
110	Test signal, O.181 specific mapping																								
111	VC-AIS																								
Bit 8	Set to 1 to indicate a VC-2/VC-1 path Remote Defect Indication (LP-RDI); otherwise set to zero.																								
<b>J2</b>	Used to repetitively transmit a Lower-Order Access Path Identifier so that a path receiving terminal can verify its continued connection to the intended transmitter. A 16-byte frame is defined for the transmission of Path Access Point Identifiers. This 16-byte frame is identical to the 16-byte frame of the J1 and J0 bytes.																								

**Table 7 (contd)**

Byte	Description																																	
<b>N2</b>	Allocated for Tandem Connection Monitoring for the VC2, VC-12, and VC-11 level.																																	
	<table border="1" style="margin-left: auto; margin-right: auto;"> <tr> <td colspan="2" style="text-align: center;"><b>BIP-2</b></td> <td style="text-align: center;"><b>"1"</b></td> <td style="text-align: center;"><b>Incoming AIS</b></td> <td style="text-align: center;"><b>TC-REI</b></td> <td style="text-align: center;"><b>OEI</b></td> <td colspan="2" style="text-align: center;"><b>TC-APId, TC-RDI, ODI, reserved</b></td> </tr> <tr> <td style="text-align: center;"><b>b1</b></td> <td style="text-align: center;"><b>b2</b></td> <td style="text-align: center;"><b>b3</b></td> <td style="text-align: center;"><b>b4</b></td> <td style="text-align: center;"><b>b5</b></td> <td style="text-align: center;"><b>b6</b></td> <td style="text-align: center;"><b>b7</b></td> <td style="text-align: center;"><b>b8</b></td> </tr> </table>	<b>BIP-2</b>		<b>"1"</b>	<b>Incoming AIS</b>	<b>TC-REI</b>	<b>OEI</b>	<b>TC-APId, TC-RDI, ODI, reserved</b>		<b>b1</b>	<b>b2</b>	<b>b3</b>	<b>b4</b>	<b>b5</b>	<b>b6</b>	<b>b7</b>	<b>b8</b>																	
<b>BIP-2</b>		<b>"1"</b>	<b>Incoming AIS</b>	<b>TC-REI</b>	<b>OEI</b>	<b>TC-APId, TC-RDI, ODI, reserved</b>																												
<b>b1</b>	<b>b2</b>	<b>b3</b>	<b>b4</b>	<b>b5</b>	<b>b6</b>	<b>b7</b>	<b>b8</b>																											
Bits 1-2	Used as an even BIP-2 for the Tandem Connection.																																	
Bit 3	Fixed to "1". This guarantees that the contents of N2 is not all zeroes at the TC-source. This enables the detection of an unequipped or supervisory unequipped signal at the Tandem Connection sink without the need of monitoring further OH-bytes.																																	
Bit 4	Operates as an "incoming AIS" indicator.																																	
Bit 5	Operates as the TC-REI of the Tandem Connection to indicate errored blocks caused within the Tandem Connection.																																	
Bit 6	Operates as the OEI to indicate errored blocks of the egressing VC-n.																																	
Bits 7-8	Operate in a 76 multiframe as: <ul style="list-style-type: none"> <li>– The access point identifier of the Tandem Connection (TC-APId); it complies with the generic 16-byte string format given in 9.2.2.2.</li> <li>– The TC-RDI, indicating to the far end that defects have been detected within the Tandem Connection at the near end Tandem Connection sink.</li> <li>– The ODI, indicating to the far end that TU-AIS has been inserted at the TC-sink into the egressing TU-n due to defects before or within the Tandem Connection.</li> <li>– Reserved capacity (for future standardization).</li> </ul> <table style="margin-left: 20px;"> <thead> <tr> <th>Frame #</th> <th>Bits 7-8 definition</th> </tr> </thead> <tbody> <tr> <td>1-8</td> <td>Frame Alignment Signal: 1111 1111 1111 1110</td> </tr> <tr> <td>9-12</td> <td>TC-APId byte #1 [ 1 C1C2C3C4C5C6C7]</td> </tr> <tr> <td>13-16</td> <td>TC-APId byte #2 [ 0 X X X X X X X ]</td> </tr> <tr> <td>17-20</td> <td>TC-APId byte #3 [ 0 X X X X X X X ]</td> </tr> <tr> <td style="text-align: center;">⋮</td> <td style="text-align: center;">⋮</td> </tr> <tr> <td>65-68</td> <td>TC-APId byte #15 [ 0 X X X X X X X ]</td> </tr> <tr> <td>69-72</td> <td>TC-APId byte #16 [ 0 X X X X X X X ]</td> </tr> <tr> <td>73-76</td> <td>TC-RDI, ODI and Reserved (see following)</td> </tr> </tbody> </table> <table style="margin-left: 20px; margin-top: 10px;"> <thead> <tr> <th>Frame #</th> <th>Bit 7 definition</th> <th>Bit 8 definition</th> </tr> </thead> <tbody> <tr> <td>73</td> <td>Reserved (default = "0")</td> <td>TC-RDI</td> </tr> <tr> <td>74</td> <td>ODI</td> <td>Reserved (default = "0")</td> </tr> <tr> <td>75</td> <td>Reserved (default = "0")</td> <td>Reserved (default = "0")</td> </tr> <tr> <td>76</td> <td>Reserved (default = "0")</td> <td>Reserved (default = "0")</td> </tr> </tbody> </table>	Frame #	Bits 7-8 definition	1-8	Frame Alignment Signal: 1111 1111 1111 1110	9-12	TC-APId byte #1 [ 1 C1C2C3C4C5C6C7]	13-16	TC-APId byte #2 [ 0 X X X X X X X ]	17-20	TC-APId byte #3 [ 0 X X X X X X X ]	⋮	⋮	65-68	TC-APId byte #15 [ 0 X X X X X X X ]	69-72	TC-APId byte #16 [ 0 X X X X X X X ]	73-76	TC-RDI, ODI and Reserved (see following)	Frame #	Bit 7 definition	Bit 8 definition	73	Reserved (default = "0")	TC-RDI	74	ODI	Reserved (default = "0")	75	Reserved (default = "0")	Reserved (default = "0")	76	Reserved (default = "0")	Reserved (default = "0")
Frame #	Bits 7-8 definition																																	
1-8	Frame Alignment Signal: 1111 1111 1111 1110																																	
9-12	TC-APId byte #1 [ 1 C1C2C3C4C5C6C7]																																	
13-16	TC-APId byte #2 [ 0 X X X X X X X ]																																	
17-20	TC-APId byte #3 [ 0 X X X X X X X ]																																	
⋮	⋮																																	
65-68	TC-APId byte #15 [ 0 X X X X X X X ]																																	
69-72	TC-APId byte #16 [ 0 X X X X X X X ]																																	
73-76	TC-RDI, ODI and Reserved (see following)																																	
Frame #	Bit 7 definition	Bit 8 definition																																
73	Reserved (default = "0")	TC-RDI																																
74	ODI	Reserved (default = "0")																																
75	Reserved (default = "0")	Reserved (default = "0")																																
76	Reserved (default = "0")	Reserved (default = "0")																																
<b>K4</b>	Bits 1-4 are allocated for APS signalling for protection at the Lower-Order path level. Bits 5-7 are reserved for optional use. Bit 8 is reserved for future use and has no defined value.																																	



# SDH Anomalies, Defects, Failures, and Alarms

The SDH frame structure has been designed to contain a large amount of overhead information. The overhead information provides for a variety of management and other functions such as:

- Alarm Indication Signals (AIS)
- Error Performance Monitoring using BIP-N
- Pointer Adjustment Information
- Path Status
- Path Trace
- Section Trace
- Remote Defect, Error, and Failure Indications
- Signal Labels
- New Data Flag Indications
- Data Communications Channels (DCC)
- Automatic Protection Switching (APS) Control
- Orderwire
- Synchronisation Status Message

Much of this overhead information is involved with alarm and in-service monitoring of the particular SDH sections. Table 8 and Figure 9, that follow the definitions, list the criteria for errors and the performance monitoring for errors.

## Definitions

**Alarm** – The maintenance signal used in the digital network to alert downstream equipment that a defect or equipment failure has been detected.

**Anomaly** – The smallest discrepancy which can be observed between the actual and desired characteristics of an item. The occurrence of a single anomaly does not constitute an interruption in the ability to perform a required function. Examples of SDH anomalies are:

- B1 BIP
- B2 BIP
- Path B3 BIP
- REI
- Pattern Bit (OOS test)

**Defect** – The density of anomalies has reached a level where the ability to perform a required function has been interrupted. Defects are used as input for performance monitoring, the control of consequent actions, and the determination of fault cause. Examples of SDH Defects are:

- OOF
- AIS
- RDI
- LOF
- LOP
- LOM

**Failure** – The inability of a function to perform a required action which has persisted beyond a maximum time allocated.

## SDH Error Performance Monitoring

Error performance monitoring in the SDH is based on Bit-Interleaved-Parity (BIP) checks calculated on a frame-by-frame basis. These BIP checks are inserted in the Regenerator Section Overhead, Multiplex Section Overhead, and Path Overheads.

In addition, Higher-Order Path Terminating Equipment (HO PTE) and Lower-Order Path Terminating Equipment (LO PTE) produce Remote Error Indications (REI) based on errors detected in the HO Path and LO Path BIP respectively. The REI signals are sent back to the equipment at the originating end of a path. All defects listed in Figure 8 are described in Table 8.

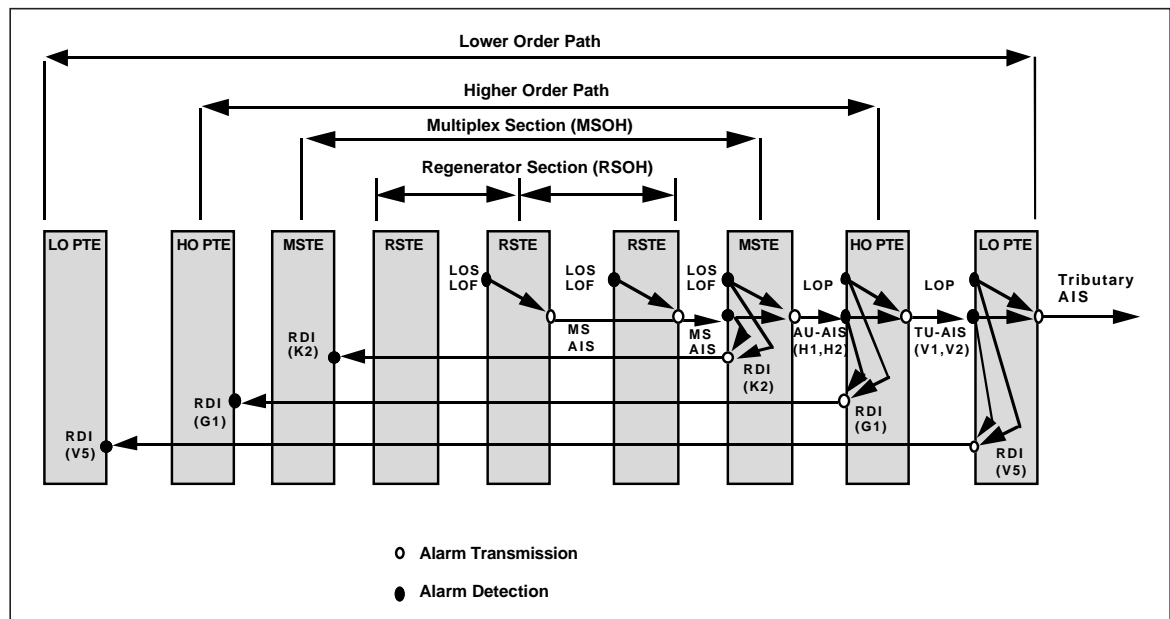

Figure 8. Interaction between defects in forward and backward directions, according to the different SDH levels.

**Table 8. Anomalies, Defects, Failures, Alarms**

Abbreviation	Description	Criteria
LOS	Loss of Signal	LOS is raised when the synchronous signal (STM-N) level drops below the threshold at which a BER of 1 in 10 <sup>3</sup> is predicted. It could be due to a cut cable, excessive attenuation of the signal, or equipment fault. The LOS state will clear when two consecutive framing patterns are received and no new LOS condition is detected.
OOF	Out of Frame alignment	OOF state occurs when several consecutive SDH frames are received with invalid (errored) framing patterns (A1 and A2 bytes). The maximum time to detect OOF is 625 microseconds. OOF state clears within 250 microseconds when two consecutive SDH frames are received with valid framing patterns.
LOF	Loss of Frame alignment	LOF state occurs when the OOF state exists for a specified time in microseconds. The LOF state clears when an in-frame condition exists continuously for a specified time in microseconds. The time for detection and clearance is normally 3 milliseconds.
LOP	Loss of Pointer	LOP state occurs when N consecutive invalid pointers are received or N consecutive New Data Flags (NDF) are received (other than in a concatenation indicator), where N = 8, 9, or 10. LOP state is cleared when three equal valid pointers or three consecutive AIS indications are received.  LOP can be identified as: <ul style="list-style-type: none"> <li>• AU-LOP (Administrative Unit Loss of Pointer)</li> <li>• TU-LOP (Tributary Unit Loss of Pointer)</li> </ul>
AIS	Alarm Indication Signal	AIS is an all-ONES characteristic or adapted information signal. It's generated to replace the normal traffic signal when it contains a defect condition in order to prevent consequential downstream failures being declared or alarms being raised.  AIS can be identified as: <ul style="list-style-type: none"> <li>• MS-AIS (Multiplex Section Alarm Indication Signal)</li> <li>• AU-AIS (Administrative Unit Alarm Indication Signal)</li> <li>• TU-AIS (Tributary Unit Alarm Indication Signal)</li> </ul>
REI	Remote Error Indication	An indication returned to a transmitting node (source) that an errored block has been detected at the receiving node (sink). This indication was previously known as FEBE (Far End Block Error).  REI can be identified as: <ul style="list-style-type: none"> <li>• MS-REI (Multiplex Section Remote Error Indication)</li> <li>• HP-REI (Higher-order Path Remote Error Indication)</li> <li>• LP-REI (Lower-order Path Remote Error Indication)</li> </ul>
RDI	Remote Defect Indication	A signal returned to the transmitting Terminating Equipment upon detecting a Loss of Signal, Loss of Frame, or AIS defect. RDI was previously known as FERF (Far End Receiver Failure).  RDI can be identified as: <ul style="list-style-type: none"> <li>• MS-RDI (Multiplex Section Remote Defect Indication)</li> <li>• HP-RDI (Higher-order Path Remote Defect Indication)</li> <li>• LP-RDI (Lower-order Path Remote Defect Indication)</li> </ul>
RFI	Remote Failure Indication	A failure is a defect that persists beyond the maximum time allocated to the transmission system protection mechanisms. When this situation occurs, an RFI is sent to the far end and will initiate a path protection switch if this function has been provisioned.  RFI can be identified as: <ul style="list-style-type: none"> <li>• LP-RFI (Lower-order Path Remote Failure Indication)</li> </ul>
B1 error	B1 error	Parity errors evaluated by byte B1 (BIP-8) of an STM-N shall be monitored. If any of the eight parity checks fail, the corresponding block is assumed to be in error.
B2 error	B2 error	Parity errors evaluated by byte B2 (BIP-24 x N) of an STM-N shall be monitored. If any of the N x 24 parity checks fail, the corresponding block is assumed to be in error.
B3 error	B3 error	Parity errors evaluated by byte B3 (BIP-8) of a VC-N (N = 3,4) shall be monitored. If any of the eight parity checks fail, the corresponding block is assumed to be in error.
BIP-2 error	BIP-2 error	Parity errors contained in bits 1 and 2 (BIP-2) of byte V5 of a VC-m (m=11,12,2) shall be monitored. If any of the two parity checks fail, the corresponding block is assumed to be in error.
LSS	Loss of Sequence Synchronisation	Out-of-service bit error measurements using pseudo-random sequences can only be performed if the reference sequence produced on the receiving side of the test set-up is correctly synchronised to the sequence coming from the object under test. In order to achieve compatible measurement results, it's necessary that the sequence synchronisation characteristics are specified. The following requirement is applicable to all ITU-T O.150 Recommendations dealing with error performance measurements using pseudo-random sequences.  Sequence synchronisation shall be considered to be lost and re-synchronisation shall be started if: <ul style="list-style-type: none"> <li>• The bit error ratio is <math>\geq 0.20</math> during an integration interval of 1 second; or</li> <li>• It can be unambiguously identified that the test sequence and the reference sequence are out of phase.</li> </ul>

# SDH Pointers

SDH provides payload pointers to permit differences in the phase and frequency of the Virtual Containers (VC-N) with respect to the STM-N frame. Lower-order pointers are also provided to permit phase differences between VC-1/VC-2 and the higher-order VC-3/VC-4.

On a frame-by-frame basis, the payload pointer indicates the offset between the VC payload and the STM-N frame by identifying the location of the first byte of the VC in the payload. In other words, the VC is allowed to “float” within the STM-1 frame capacity.

To make this possible, within each STM-N frame, there’s a pointer, known as the VC Payload Pointer, that indicates where the actual payload container starts. For a VC-4 payload, this pointer is located in columns 1 and 4 of the fourth row of the Section Overhead. The bytes H1 and H2 (two 8-bit bytes) of the Overhead can be viewed as one value (see Figure 9).

The pointer value indicates the offset in bytes from the pointer to the first byte of the

VC, which is the J1 byte. Because the Section Overhead bytes are not counted, and starting points are at 3-byte increments for a VC-4 payload, the possible range is:

$$\text{Total STM-1 bytes} - \text{Section Overhead bytes} = \text{Pointer value range}$$

For example:

$$(2430 - 81) / 3 = 783 \text{ valid pointer positions}$$

That is, the value of the pointer has a range of 0 to 782. For example, if the VC-4 Payload Pointer has a value of 0, then the VC-4 begins in the byte adjacent to the H3 byte of the Overhead; if the Payload Pointer has a value of 87, then the VC-4 begins in the byte adjacent to the K2 byte of the Overhead in the next row.

The pointer value, which is a binary number, is carried in bits 7 through 16 of the H1-H2 pointer word. The first four bits of the VC-4 payload pointer make provision for indicating a change in the VC, and thus an arbitrary change in the value of the pointer.

These four bits, the N-bits, are known as the New Data Flag. The VC pointer value that accompanies the New Data Flag will indicate the new offset.

## Payload Pointers

When there’s a difference in phase or frequency, the pointer value is adjusted. To accomplish this, a process known as byte stuffing is used. In other words, the VC payload pointer indicates where in the container capacity a VC starts, and the byte stuffing process allows dynamic alignment of the VC in case it slips in time.

## Positive Pointer Justification

When the data rate of the VC is too slow in relation to the rate of the STM-1 frame, bits 7, 9, 11, 13, and 15 of the pointer word are inverted in one frame, thus allowing 5-bit majority voting at the receiver (these bits are known as the I-bits or Increment bits). Periodically, when the VC is about one byte off, these bits are inverted, indicating that positive stuffing must occur.

An additional byte is stuffed in, allowing the alignment of the container to slip back in time. This is known as positive stuffing, and the stuff byte is made up of non-information bits. The actual positive stuff byte immediately follows the H3 byte (that is, the stuff byte is within the VC portion). The pointer is incremented by one in the next frame, and the subsequent pointers contain the new value.

**Table 9. SDH Pointers**

Byte	Description
H1 and H2	<b>Pointer bytes</b> – These two bytes, the VC payload pointer, specify the location of the VC frame. It’s used to align the VC and STM-1 Section Overheads in an STM-N signal, to perform frequency justification, and to indicate STM-1 concatenation.
H3	<b>Pointer action byte</b> – This byte is used for frequency justification. Depending on the pointer value, the byte is used to adjust the fill input buffers. The byte only carries valid information in the event of negative justification, otherwise it’s not defined.

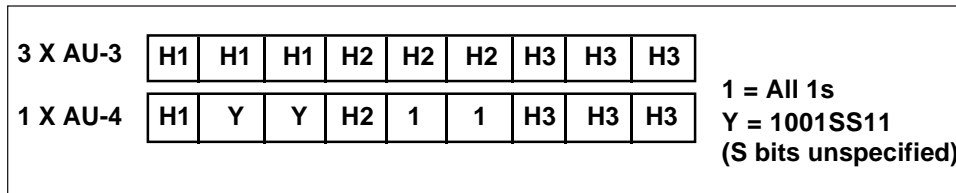

Figure 9. Pointer 9-byte structure.

Simply put, if the VC is running more slowly than the STM-1 frame, every now and then “stuffing” an extra byte in the flow gives the VC a one-byte delay (see Figure 10).

### Negative Pointer Justification

Conversely, when the data rate of the VC is too fast in relation to the rate of the STM-1 frame, bits 8, 10, 12, 14, and 16 of the pointer word are inverted, thus allowing 5-bit majority voting at the receiver (these bits are

known as the D-bits, or Decrement bits). Periodically, when the VC is about one byte off, these bits are inverted, indicating that negative stuffing must occur.

Because the alignment of the container advances in time, the payload capacity must be moved forward. Thus, actual data is written in the H3 byte, the negative stuff opportunity within the Overhead; this is known as negative stuffing. The pointer is decremented by one in the next frame, and the subsequent pointers

contain the new value. Simply put, if the VC is running more quickly than the STM-1 frame, every now and then pulling an extra byte from the flow and stuffing it into the Overhead capacity (the H3 byte) gives the VC a one-byte advance (see Figure 11).

In both positive or negative cases, there must be at least three frames in which the pointer remains constant before another stuffing operation (and, therefore a pointer value change) can occur.

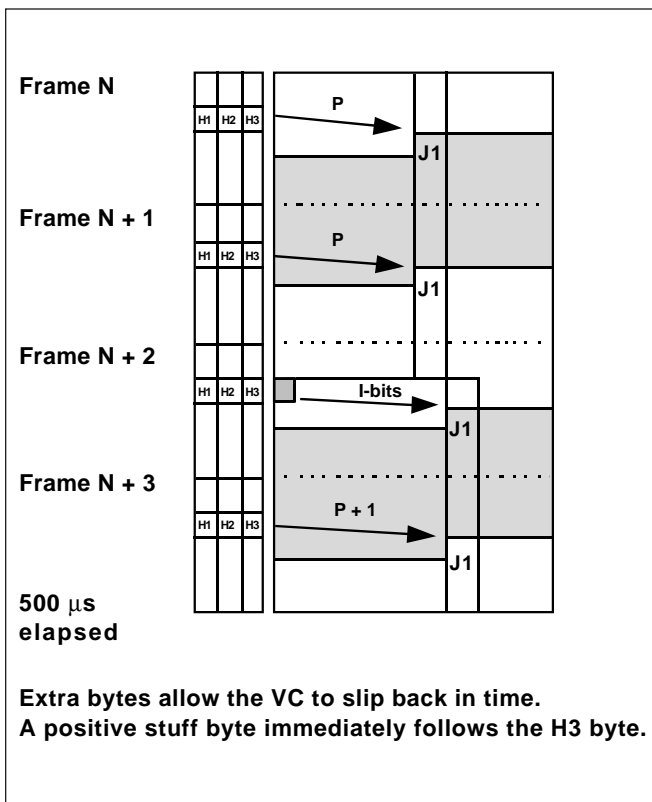

Figure 10. Payload pointer – positive justification.

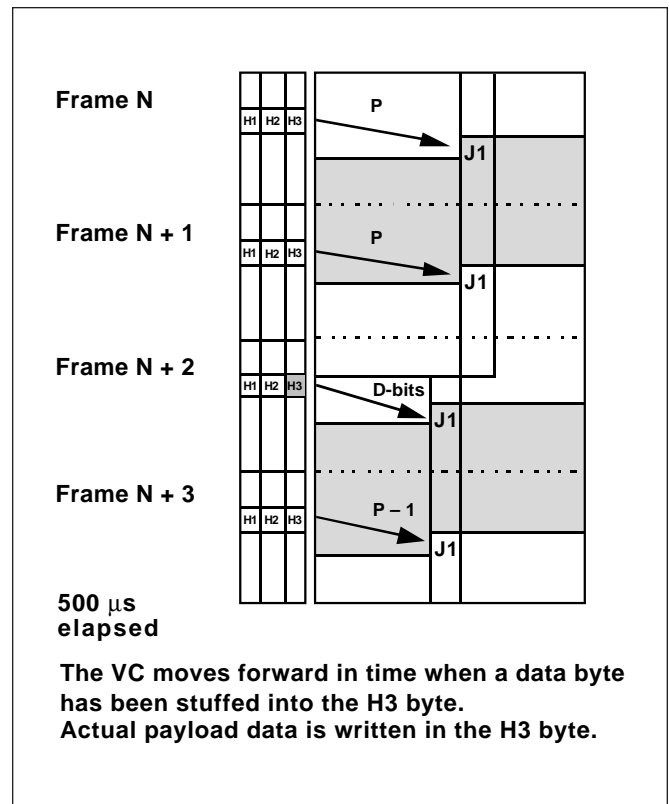

Figure 11. Payload pointer – negative justification.



# SDH Multiplexing

The multiplexing principles of SDH follow, using these terms and definitions:

- **Mapping** – A process used when tributaries are adapted into Virtual Containers (VCs) by adding justification bits and Path Overhead (POH) information.
- **Aligning** – This process takes place when a pointer is included in a Tributary Unit (TU) or an Administrative Unit (AU), to allow the first byte of the Virtual Container to be located.
- **Multiplexing** – This process is used when multiple lower-order path layer signals are adapted into a higher-order path signal, or when the higher-order path signals are adapted into a Multiplex Section.

- **Stuffing** – As the tributary signals are multiplexed and aligned, some spare capacity has been designed into the SDH frame to provide enough space for all the various tributary rates. Therefore, at certain points in the multiplexing hierarchy, this space capacity is filled with “fixed stuffing” bits that carry no information, but are required to fill up the particular frame.

Figure 12 illustrates the ITU-T SDH multiplexing structure defined in Rec. G.707. The notations in the boxes, such as C-1, VC-3, and AU-4, are explained in Table 10.

At the lowest level, containers (C) are input to virtual containers (VC). The purpose of this function is to create a uniform VC payload by using bit-stuffing to bring all inputs to a common bit-rate ready for synchronous multiplexing. Various

containers (ranging from VC-11 at 1.728 Mbit/s to VC-4 at 150.336 Mbit/s) are covered by the SDH hierarchy. Next, VCs are aligned into tributary units (TUs), where pointer processing operations are implemented. These initial functions allow the payload to be multiplexed into TU groups (TUGs). As Figure 12 illustrates, the xN label indicates the multiplexing integer used to multiplex the TUs to the TUGs. The next step is the multiplexing of the TUGs to higher level VCs, and TUG-2 and TUG-3 are multiplexed into VC-3 (ANSI mappings) and VC-4. These VCs are multiplexed with fixed byte-stuffing to form administrative units (AUs) which are finally multiplexed into the AU group (AUG). This payload then is multiplexed into the Synchronous Transport Module (STM).

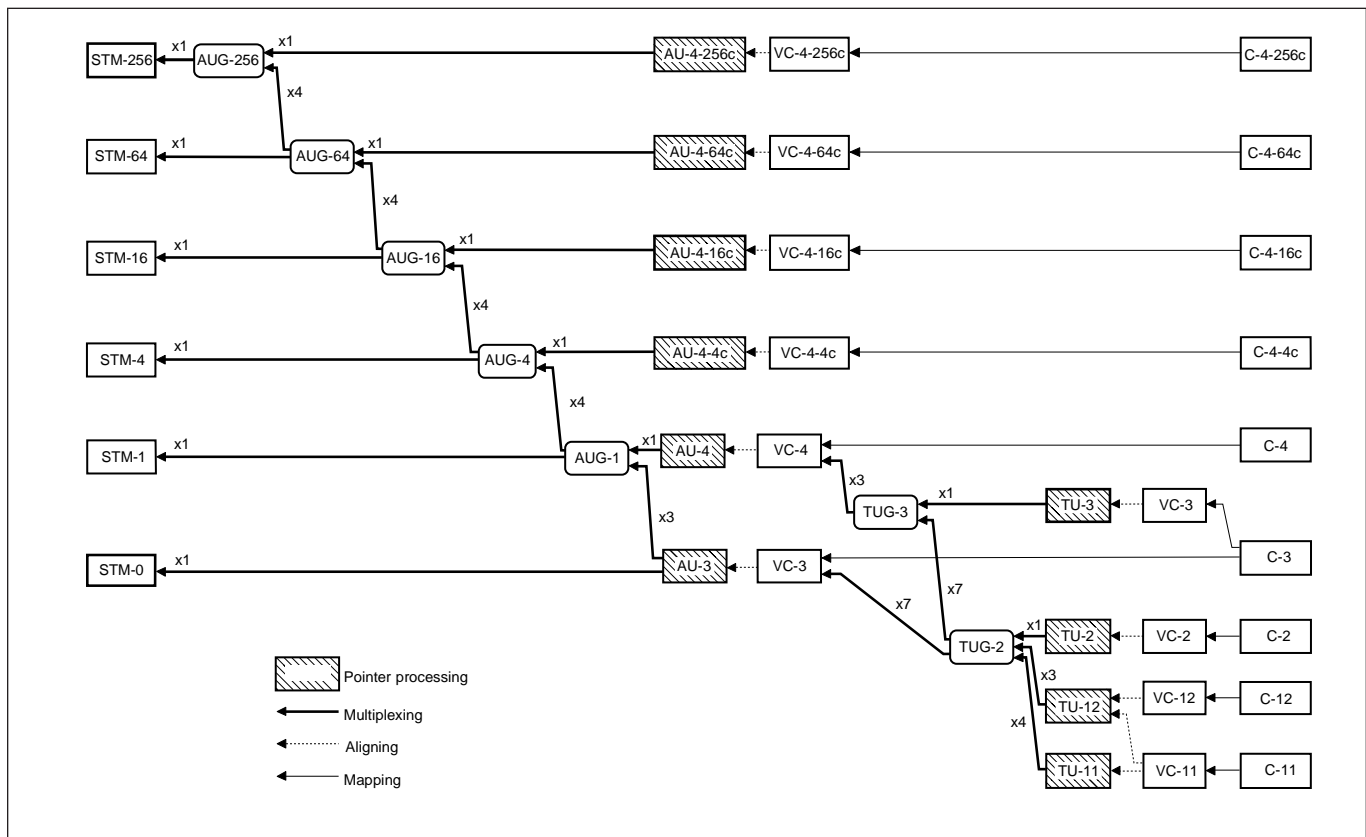

Figure 12. SDH multiplexing structure.

**Table 10. SDH Multiplexing Structure**

<b>Term</b>	<b>Contents</b>	<b>User</b>
C-N	N = 1 to 4	Payload at lowest multiplexing level
VC-N	N = 1, 2 (Lower-Order)	Single C-n plus VC POH
VC-N	N = 3, 4 (Higher-Order)	C-N, TUG-2s, or TUG-3s, plus POH for the specific level
TU-N	N = 1 to 3	VC-N plus tributary unit pointer
TUG-2	1, 3 or 4 (TU-N)	Multiplex of various TU-Ns
TUG-3	TU-3 or 7 TUG-2s	TU-3 or multiplex of 7 TUG-2s
AU-N	N = 3, 4	VC-N plus AU pointer
AUG	1, 3 (AU-n)	Either 1 AU-4 or multiplex of 3 AU-3s
STM-N	N = 1, 4, 16, 64 AUGs	N synchronously-multiplexed STM-1 signals

POH = Path Overhead

C = Container

TU = Tributary Unit

AU = Administrative Unit

VC = Virtual Container

TUG = Tributary Unit Group

STM = Synchronous Transport Module

# SDH Tributary Multiplexing

In order to accommodate mixes of different TU types within a VC-4, the TUs are grouped together (refer to the previous SDH Multiplexing Hierarchy diagram – Figure 12). A VC-4 that is carrying Tributary Units is divided into three TUG-3, each of which may contain seven TUG-2s or a single TU-3. There can be a mix of the different TU Groups. For example, the first TUG-3 could contain twelve TU-12 and three TU-2, making a total of seven TUG-2 groups. The TU groups have no overhead or pointers; they are just a way of multiplexing and organizing the different TUs within the VC-4 of a STM-1. The columns in a TU Group are not consecutive within the VC; they are byte-interleaved column-by-column with respect to the other TU groups (see Figure 13).

This figure also shows several columns allocated for fixed stuffing. NPI (Null Pointer Indicators) are used to indicate when a TUG-2 structure is being carried, rather than a TU-3 with its associated TU-3 pointer.

## Tributary Unit Group

The first TUG-2 Group within a TUG-3, called Group 1, is found in every seventh column, skipping columns 1 and 2 of the TUG-3, and starting with column 3.

The Tributary Unit columns within a group are not placed in consecutive columns within that group. The columns of the individual TUs within the TU Group are byte-interleaved as well.

Tributary Units are optimized in different sizes to accommodate different signals. Each size of TU is known as a “type” of TU. A 36-byte structure, or 4 columns by 9 rows,

could accommodate the 2.048 Mbit/s signal. This particular TU is simply designated a TU-12. In this case the four columns provide a signal rate of 2.304 Mbit/s, allowing capacity for overhead. Other signals require TUs of different sizes.

With each TU Group using 12 columns of the VC-4, note that the number of columns in each of the different Lower-Order TU types are all factors of 12. As a result, a TU group could contain one of the following combinations:

- Three TU-12s (with four columns per TU-12)
- One TU-2 (with twelve columns per TU-2)

## TU Multiframe

In the floating TU mode, four consecutive 125-microsecond frames of the VC-4 are combined into one 500-microsecond structure, called a TU Multiframe. In other words, the 500-microsecond multiframe is overwritten on, and aligned to the 125-microsecond VC-4s. The occurrence of the TU Multiframe and its phase is indicated in the VC-N Path Overhead, by the Multiframe Indicator byte (H4). A value XXXXXX00 in the Multiframe Indicator byte indicates that the next STM frame contains the first frame in the TU Multiframe; a value XXXXXX01 in the Multiframe Indicator byte indicates that the next VC-4 contains the second frame in the TU Multiframe, and so on. (Only the last two bits of the H4 byte have a value of 0 or 1 assigned; the first six bits are unassigned and this is denoted by the X.)

The Tributary Units also contain payload pointers to allow for flexible and dynamic alignment of the VC. In this case, the TU pointer value indicates the offset from the TU to the first byte of the VC. TU pointers allow

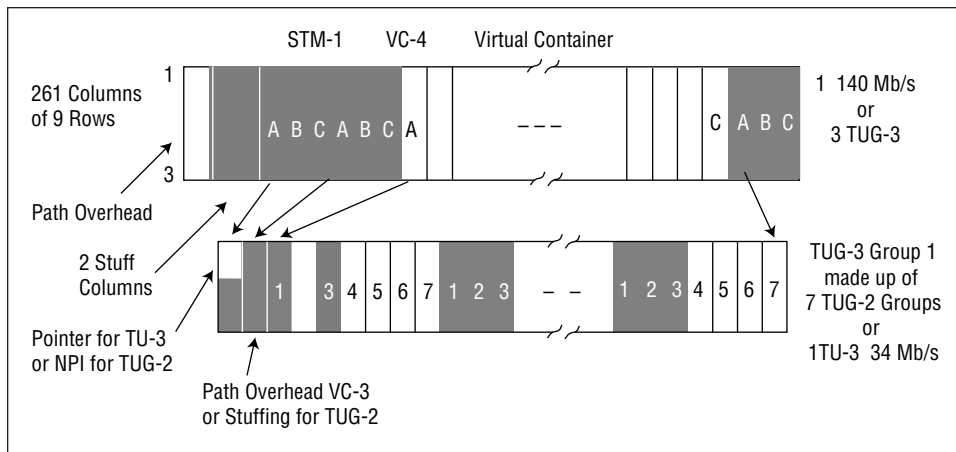

Figure 13. SDH tributary structure showing TUG-3 multiplexing in VC-4.

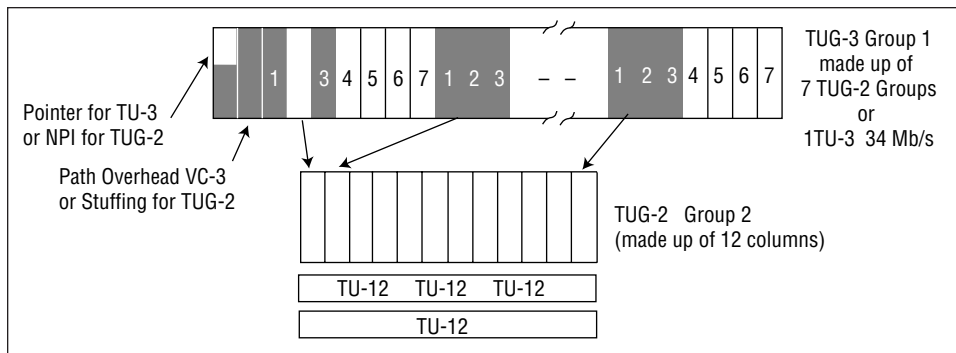

Figure 14. Tributary unit structures.

AU and TU payloads to differ in phase with respect to each other and the network while still allowing AUs and TUs to be synchronously multiplexed.

The TU Multiframe overhead consists of four bytes: V1, V2, V3, and V4 (see Figure 15). Each of these four bytes, V1 to V4, is located in the first byte of the respective TU frame in the TU Multiframe. The payload pointers V1 and

V2 indicate the start of the payload within the multiframe and V3 provides a 64 kbit/s channel for a payload pointer movement opportunity. The V4 byte is reserved. The remaining bytes in the TU Multiframe define the TU container capacity which carries the Virtual Container, and the Path Overhead. The container capacity differs for the different TU types because

their size varies according to the number of columns in each type.

The container capacity for each type of TU is shown in Table 11.

### TU Payload Pointer

The TU Payload Pointer allows dynamic alignment of the lower-order VC-M within the TU Multiframe in much the same fashion as described for the higher-order VC-N. The alignment of any one lower-order VC-M is independent of the other VC-Ms; in other words, all VCs within an STM can float independently of each other.

This payload pointer, which is located in positions V1 and V2 of the TU Multiframe, is made up of two 8-bit bytes, and it can be viewed as one word. The value of the pointer is a binary number found in bits 7 to 16 of V1 and V2. This value indicates the offset in bytes from the end of the pointer (byte V2) to the first byte of the VC; the V3 and V4 bytes are not counted. The range of the offset differs for each TU type (see Table 12).

That is, the value of the pointer for a TU-12 has a range of 0 to 140. For example, if the TU Payload Pointer has a value of 0, then the VC-M begins in the byte adjacent to the V2 byte; if the TU Payload Pointer has a value of 35, then the VC-M begins in the byte adjacent to the V3 byte. The V5 byte is the first byte of the VC-M in the first multiframe.

**Table 11. TU Container Capacity**

TU Type	TU Capacity Calculation *	TU Pointer	TU Container Capacity
TU-11	3 x 9 x 4	4 bytes	104 bytes
TU-12	4 x 9 x 4	4 bytes	140 bytes
TU-2	12 x 9 x 4	4 bytes	428 bytes

\* Columns x rows x frames

**Table 12. TU Container Pointer Values**

TU Type	Total TU bytes	V1 to V4	Pointer value range
TU-11	108	4	104
TU-12	144	4	140
TU-2	432	4	428

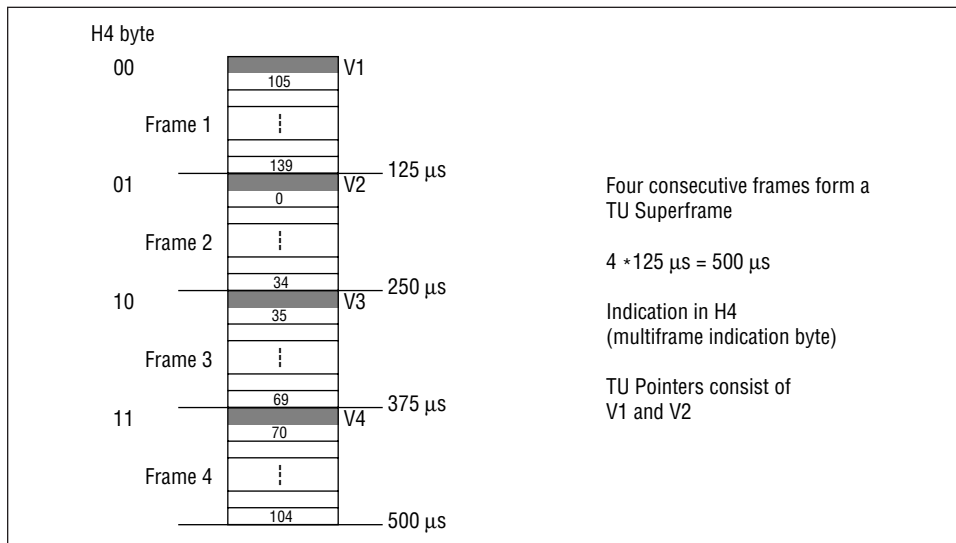

Figure 15. TU multiframe structure.

# Automatic Protection Switching

Automatic Protection Switching (APS) is the capability of a transmission system to detect a failure on a working facility and to switch to a standby facility to recover the traffic. This capability has a positive effect on the overall system availability.

Only the Multiplex Section in SDH is protected in this automatic fashion. The Multiplex Section protection mechanisms are coordinated by the K1 and K2 bytes in the Multiplex Section Overhead. Path protection is managed at a higher level by network management functions.

## Multiplex Section Protection, K1/K2 Bytes

In SDH, the transmission is protected on optical sections from the Near End (the point at which the MS Overhead is inserted) to the Far End (the point where the MS Overhead is terminated).

Bytes K1 and K2 in the MS Overhead of the STM-1 signal carry a Multiplex Section

Protection (MSP) protocol used to coordinate protection switching between the Near End and the Far End.

Protection switching is initiated as a result of one of the following situations:

- Signal failure
- Signal degradation
- In response to commands from a local craft terminal or a remote network manager

Two modes of APS are provided: 1+1 protection switching and 1:N protection switching.

The K1 byte (see Figure 16) contains both the switching pre-emption priorities (in bits 1 to 4), and the channel number of the channel requesting action (in bits 5 to 8).

The K2 byte contains the channel number of the channel that is bridged onto protection (bits 1 to 4), and the mode type (bit 5); as well, bits 6 to 8 contain various conditions such as MS-AIS, MS-RDI, indication of uni-

directional or bi-directional switching.

## 1+1 Protection

In 1+1 protection switching, there is a protection facility (backup line) for each working facility (see Figure 17).

At the Near End of the section, the optical signal is bridged permanently (split into two signals) and sent over both the working and the protection facilities simultaneously, producing a working signal and a protection signal that are identical.

At the Far End of the section, both signals are monitored independently for failures. The receiving equipment selects either the working or the protection signal. This selection is based on the switch initiation criteria which are either a signal fail (hard failure such as the loss of frame (LOF) within an optical signal), or a signal degrade (soft failure caused by the error rate exceeding some pre-defined value).

Normally, 1+1 protection switching is uni-directional, although if the line terminating equipment at both ends support bi-directional switching, the uni-directional default can be overridden.

Switching can be either revertive (the flow reverts to the working facility as soon as the failure has been corrected) or non-revertive (the protection facility is treated as the working facility).

In 1+1 protection architecture, all communication from the Near End to the Far End is carried out over the APS channel, using the K1 and K2 bytes. In 1:1 bi-directional switching, the K-byte signaling indicates to the Near End that a facility has been switched so that it can start to receive on the now active facility.

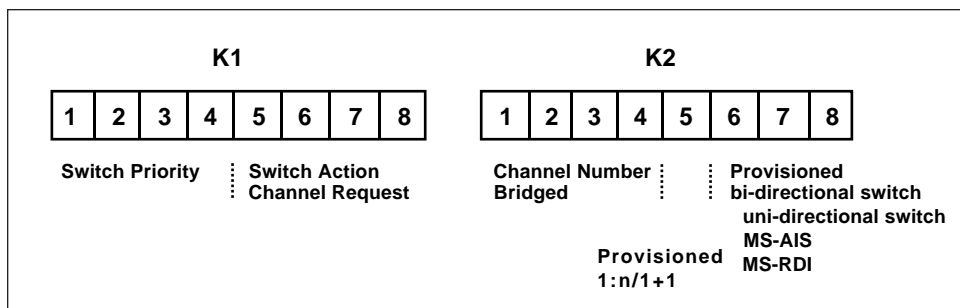

Figure 16. APS/ MSP, K1/K2 byte functions.

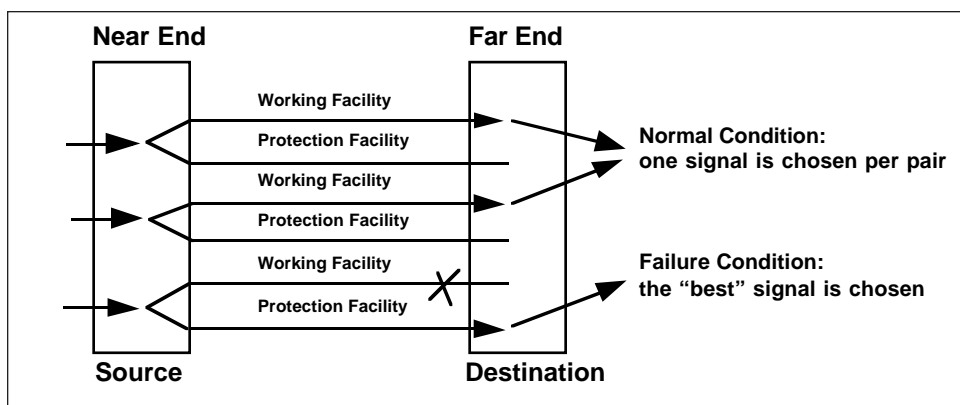

Figure 17. 1+1 protection switching.

### 1:N Protection

In 1:N protection switching, there is one protection facility for several working facilities (the range is from 1 to 14). In 1:N protection architecture, all communication from the Near End to the Far End is carried out over the APS channel, using the K1 and K2 bytes. All switching is revertive; that is, the traffic reverts to the working facility as soon as the failure has been corrected.

In 1:N protection switching, optical signals are normally sent only over the working facilities, with the protection facility being kept free until a working facility fails. Let's look at a failure in a bi-directional architecture (see Figure 18). Suppose the Far End detects a failure on working facility 2. The Far End sends a message in bits 5 to 8 of the K1 byte to the Near End over the protection facility requesting switch action. The Near End can act directly, or if there's more than one

problem, the Near End decides which is top priority. On a decision to act on the problem on working facility 2, the Near End carries out the following steps:

1. Bridges working facility 2 at the Near End to the protection facility.
2. Returns a message on the K2 byte indicating the channel number of the traffic on the protection channel to the Far End.
3. Sends a Reverse Request to the Far End via the K1 byte to initiate bi-directional switch.

On receipt of this message, the Far End carries out the following steps:

1. Switches to the protection facility to receive.
2. Bridges working facility 2 to the protection facility to transmit back.

Now transmission is carried out over the new working facility.

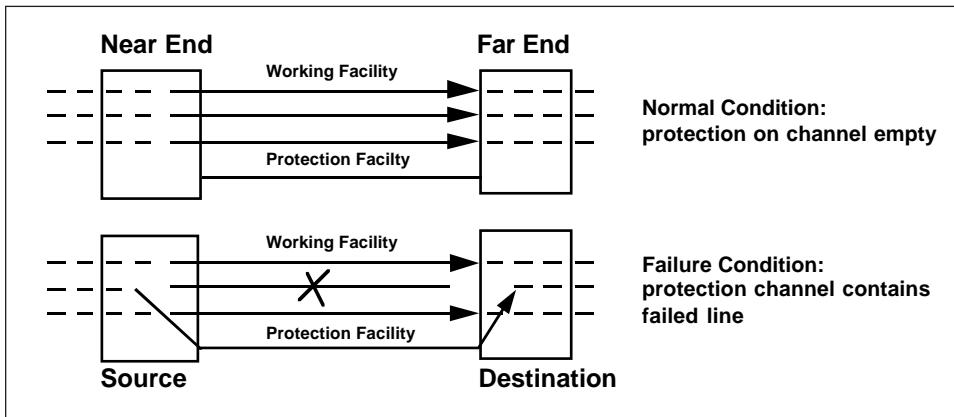

Figure 18. 1:N protection switching.

# SDH Network Elements

## Terminal Multiplexer

The path terminating element (PTE) acts as a concentrator of E1s as well as other tributary signals (see Figure 19).

Its simplest deployment would involve two terminal multiplexers linked by fibre with or without a regenerator in the link. This implementation represents the simplest SDH link (Regenerator Section, Multiplex Section, and Path, all in one link).

One of the main benefits of SDH as seen by the network operator is the network simplification brought about through the use of synchronous equip-

ment. A single synchronous node can perform the function of an entire plesiochronous “multiplexing by steps”, leading to significant reductions in the amount of equipment used and consequently space and energy savings.

## Regenerator

A regenerator (see Figure 20) is needed when, due to the long distance between multiplexers, the signal level in the fibre becomes too low.

The regenerator recovers timing from the received signal and replaces the Regenerator Section overhead bytes before re-transmitting

the signal; the Multiplex Section overhead, path overhead, and payload are not altered.

## Add/Drop Multiplexer

One of the major advantages of SDH is its ability to Add and Drop tributaries directly from higher-order aggregate bit streams.

Although network elements (NEs) are compatible at the STM-N level, they may differ in features from vendor to vendor. SDH does not restrict manufacturers from providing a single type of product, nor require them to provide all types. For example, one vendor might offer an add/drop multiplexer with access at E1 only, whereas another might offer simultaneous access at E1 and E4 rates (see Figure 21).

A single-stage multiplexer/-demultiplexer can multiplex various inputs into an STM-N signal. At an add/drop site, only those signals that need to be accessed are dropped or inserted. The remaining traffic continues through the network element without requiring special pass-through units or other signal processing.

In rural applications, an ADM can be deployed at a terminal site or any intermediate location for consolidating traffic from widely separated locations. Several ADMs can also be configured as a survivable ring.

SDH enables drop-and-continue, a key capability in both telephony and cable TV applications. With drop-and-continue, a signal terminates at one node, is duplicated, and is then sent to the next node and to subsequent nodes.

In ring-survivability applications, drop-and-continue provides alternate routing for traffic passing through interconnecting rings in a “matched-nodes” configura-

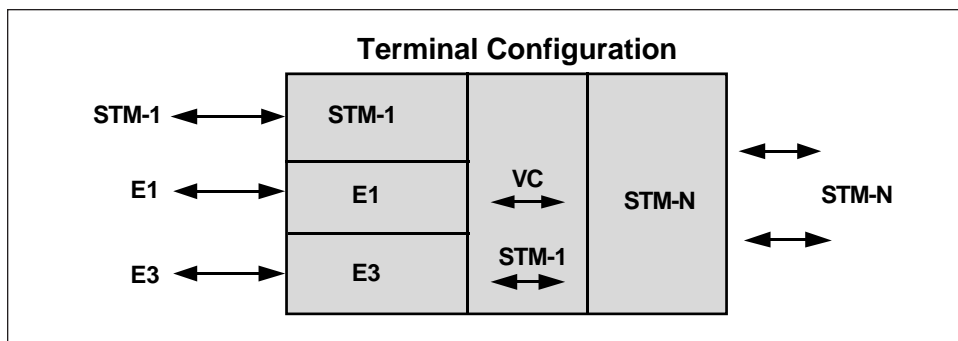

Figure 19. Terminal multiplexer example.

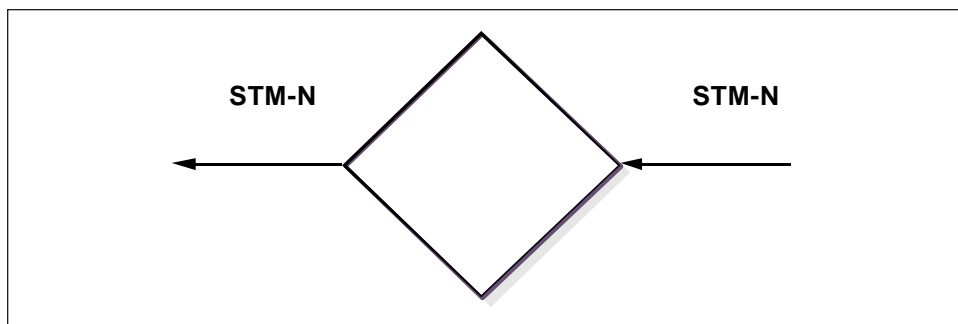

Figure 20. Regenerator.

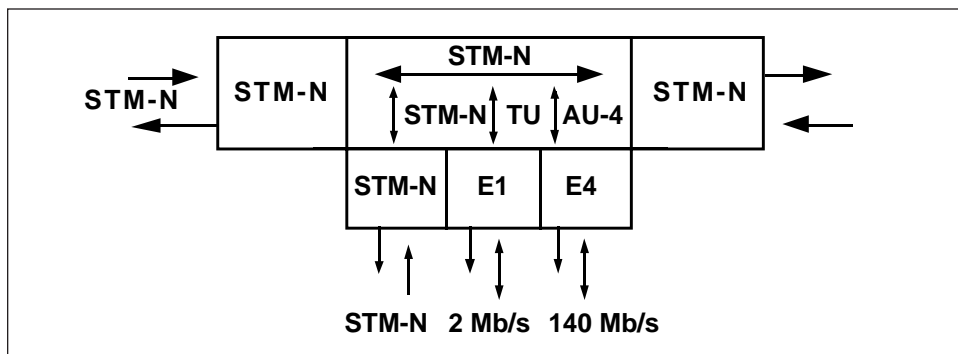

Figure 21. Add/Drop multiplexer example.

tion. If the connection cannot be made through one of the nodes, the signal is repeated and passed along an alternate route to the destination node. In multi-node distribution applications, one transport channel can efficiently carry traffic between multiple distribution nodes. When transporting video, for example, each programming channel is delivered (dropped) at the node and repeated for delivery to the next and subsequent nodes. Not all bandwidth

(program channels) need be terminated at all the nodes. Channels not terminating at a node can be passed through without physical intervention to other nodes.

### Wideband Digital Cross-connect

An SDH cross-connect accepts various SDH rates, accesses the STM-1 signals, and connects payloads, for example, at a TU-12 level (see Figure 22). One major difference between a cross-connect and an add-drop multiplexer

is that a cross-connect may be used to interconnect a much larger number of STM-1s. The cross-connect can be used for grooming (consolidating or segregating) of STM-1s or for broadband traffic management. For example, it may be used to segregate high-bandwidth from low-bandwidth traffic and send them separately to the high-bandwidth (for example video) switch and a low-bandwidth (voice) switch. It supports hubbed network architectures.

This type of cross-connect is similar to the broadband cross-connect except that the switching is done at TU-12 level. It is suitable for E1 level grooming applications at cross-connect locations. One major advantage of wideband digital cross-connects is that less demultiplexing and multiplexing is required because only the required tributaries are accessed and switched.

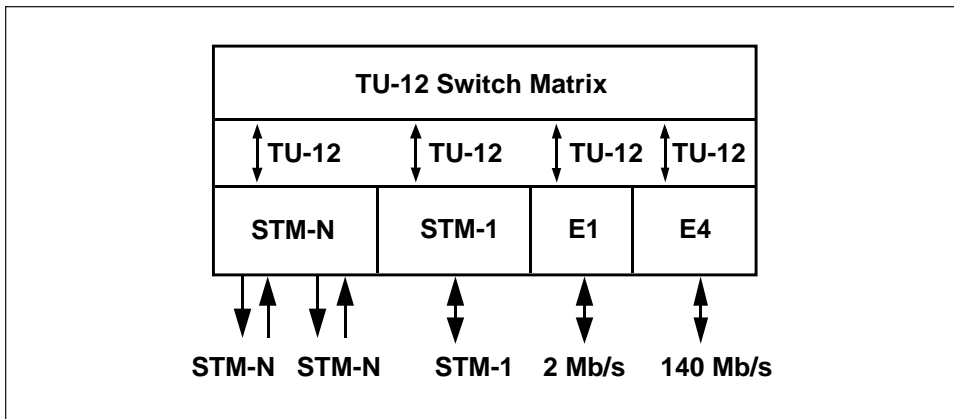

Figure 22. Wideband digital cross-connect example.

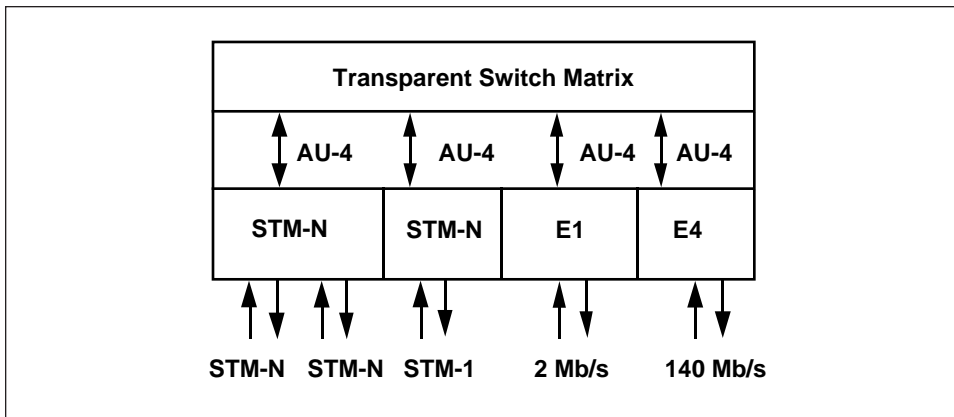

Figure 23. Broadband digital cross-connect example.

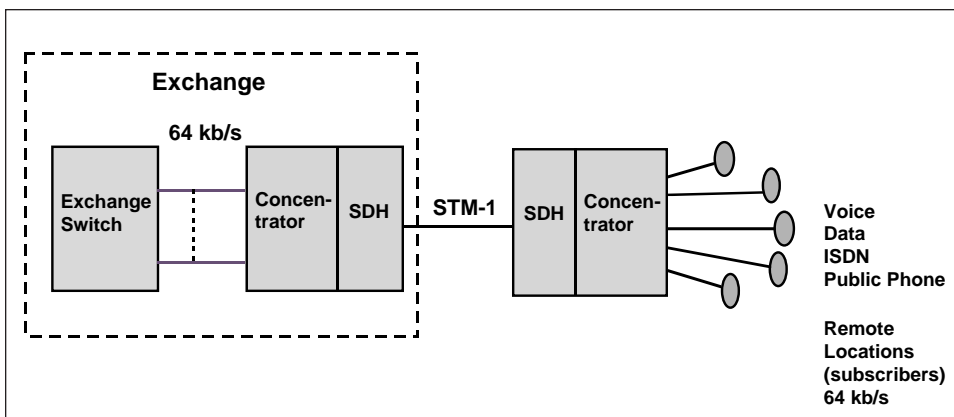

Figure 24. Flexible multiplexer example.

### Broadband Digital Cross-connect

The Broadband Digital Cross-connect interfaces SDH signals and possibly high-rate tributaries (see Figure 23). It accesses the STM-N signals, and typically switches at an AU-4 level.

It's best used as an SDH cross-connect, where it can be used for grooming STM-1s, for broadband restoration purposes, or for routing traffic.

### Flexible Multiplexer

The Flexible Multiplexer (see Figure 24) may be considered a concentrator of low-speed services before they are brought into the local exchange for distribution. If this concentration were not done, the number of subscribers (or lines) that an exchange could serve would be limited by the number of lines served by the exchange. The Flexible Multiplexer itself is actually a system of multiplexers and switches designed to perform some traffic concentration and limited switching at a remote location.



# SDH Network Configurations

## Point-to-Point

The simplest network configuration involves two terminal multiplexers linked by fibre with or without a regenerator in the link (see Figure 25).

In this configuration, the SDH path and the Service path (for example, E1 or E3 links end-to-end) are identical and this synchronous island can exist within an asynchronous network world. In the future, point-to-point service path connections will span across the whole network and will always originate and terminate in a multiplexer.

## Point-to-Multipoint

A point-to-multipoint (linear add/drop) architecture includes adding and dropping circuits along the way (see Figure 26). The SDH ADM (add/drop multiplexer) is a unique network element specifically designed for this task. It avoids the current cumbersome network architecture of demultiplexing, cross-connecting, adding and dropping channels, and then re-multiplexing. The ADM typically is placed in an SDH link to facilitate adding and dropping tributary channels at intermediate points in the network.

## Mesh Architecture

The meshed network architecture accommodates unexpected growth and change more easily than simple point-to-point networks. A cross-connect function concentrates traffic at a central site and allows easy re-provisioning of the circuits (see Figure 27).

There are two possible implementations of this type of network function:

1. Cross-connection at higher-order path levels, for example, using AU-4 granularity in the switching matrix.
2. Cross-connection at lower-order path levels, for example, using TU-12 granularity in the switching matrix.

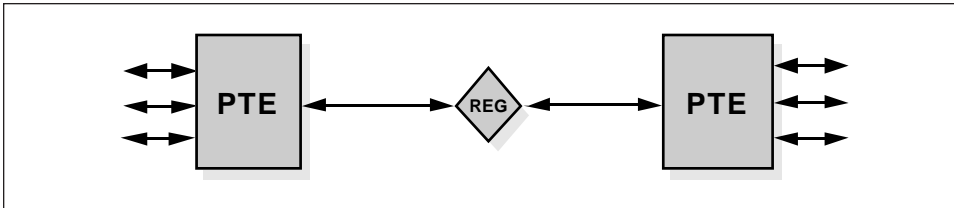

Figure 25. Point-to-point.

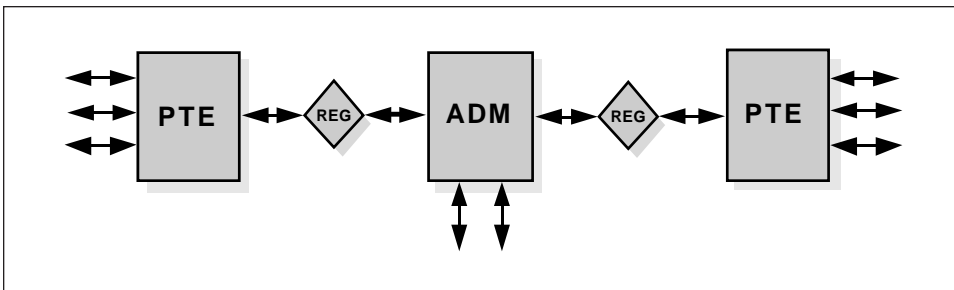

Figure 26. Point-to-multipoint.

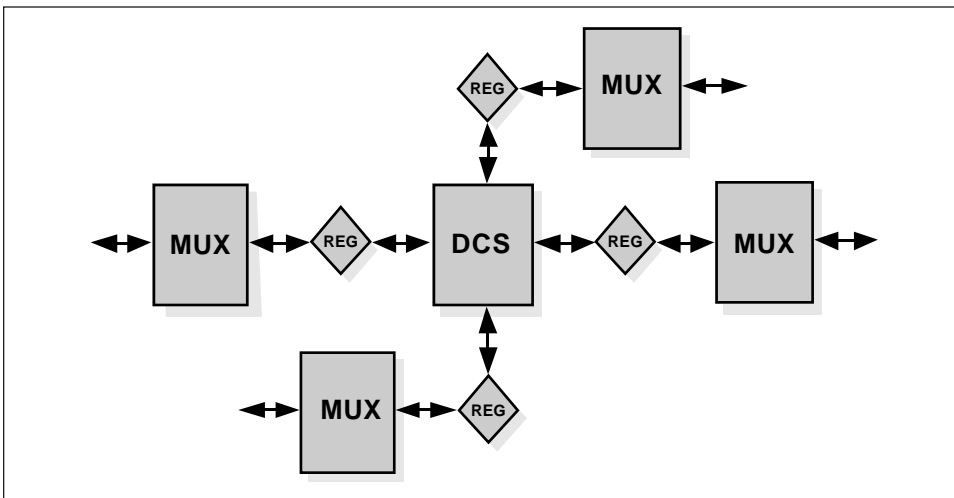

Figure 27. Mesh architecture.

### Ring Architecture

The SDH building block for a ring architecture is the ADM (see Figure 28). Multiple ADMs can be put into a ring configuration for either Bi-directional or Uni-directional traffic. The main advantage of the ring topology is its surviv-

ability; if a fibre cable is cut, for example, the multiplexers have the local intelligence to send the services affected via an alternate path through the ring without a lengthy interruption.

The demand for survivable services, diverse routing of

fibre facilities, flexibility to rearrange services to alternate serving nodes, as well as automatic restoration within seconds, have made rings a popular SDH topology.

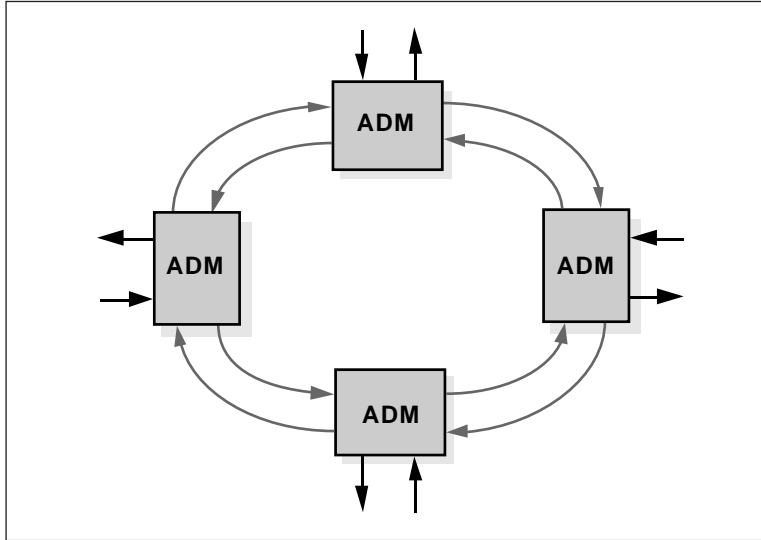

Figure 28. Ring architecture.

## Benefits of SDH – Conclusions

A transport network using SDH provides much more powerful networking capabilities than existing asynchronous systems. The key benefits provided by SDH are:

### **Pointers, MUX/DEMUX**

As a result of SDH transmission, the network clocks are referenced to a highly stable reference point; so the need to align the data streams using non-deterministic bit-stuffing is unnecessary. Therefore, a lower rate channel such as E1 is directly accessible, and intermediate demultiplexing is not needed to access the bitstreams.

For those situations in which synchronisation reference frequency and phase may vary, SDH uses pointers to allow the streams to “float” within the payload. Pointers are the key to synchronous timing; they allow a very flexible allocation and alignment of the payload within the transmission frame.

### **Reduced Back-to-Back Multiplexing**

In the asynchronous PDH systems, care must be taken when routing circuits in order to avoid multiplexing and demultiplexing too many times since electronics (and their associated capital cost) are required every time an E1 signal is processed. With SDH, E1s can be multiplexed directly to the STM-N rate. Because of synchronisation, an entire optical signal doesn't have to be demultiplexed – only the individual VC or STM signals that need to be accessed.

### **Optical Interconnect**

A major SDH benefit is that it allows mid-span meet with multi-vendor compatibility. Today's SDH standards contain definitions for fibre-to-fibre interfaces at the physical level. They determine the optical line rate, wavelength, power levels, pulse shapes,

and coding. The current standards also fully define the frame structure, overhead, and payload mappings. Enhancements are being developed to define the messages in the overhead channels to provide increased OAM functionality.

SDH allows optical interconnection between network providers regardless of who makes the equipment. The network provider can purchase one vendor's equipment and conveniently interface with other vendors' SDH equipment at either operator locations or customer premises. Users may now obtain the STM-N equipment of their choice and meet with their network provider of choice at that STM-N level.

### **Multi-point Configurations**

Most existing asynchronous transmission systems are only economic for point-to-point applications, whereas SDH can efficiently support a multi-point or cross-connected configuration.

The cross-connect allows many nodes or sites to communicate as a single network instead of as separate systems. Cross-connecting reduces requirements for back-to-back multiplexing and demultiplexing, and helps realize the benefits of traffic grooming.

Network providers no longer need to own and maintain customer-located equipment. A multi-point implementation permits STM-N interconnects and mid-span meets, allowing network providers and their customers to optimize their shared use of the SDH infrastructure.

### **Grooming**

Grooming refers to either consolidating or segregating traffic to make more efficient use of the network facilities. Consolidation means combining traffic from

different locations onto one facility, while segregation is the separation of traffic.

Grooming eliminates inefficient techniques such as back-hauling. It's possible to groom traffic on asynchronous systems, however to do so requires expensive back-to-back configurations and manual or electronic cross-connects. By contrast, an SDH system can segregate traffic at either an STM-1 or VC level to send it to the appropriate nodes.

Grooming can also provide segregation of services. For example, at an interconnect point, an incoming SDH line may contain different types of traffic, such as switched voice, leased circuits for data, or video. An SDH network can conveniently segregate the switched and non-switched traffic.

### **Enhanced OAM**

SDH allows integrated network OAM, in accordance with the philosophy of single-ended maintenance. In other words, one connection can reach all network elements within a given architecture; separate links are not required for each network element. Remote provisioning provides centralized maintenance and reduced travel for maintenance personnel – which translates to expense savings.

*Note: OAM is sometimes referred to as OAM&P.*

### **Enhanced Performance Monitoring**

Substantial overhead information is provided in SDH to allow quicker troubleshooting and detection of failures before they degrade to serious levels.

### **Convergence, ATM, Video, and SDH**

Convergence is the trend toward delivery of voice, data, images, and video through diverse transmission

and switching systems that supply high-speed transportation over any medium to any location. Tektronix is pursuing new opportunities to lead the market by providing test and measurement equipment to users who process or transport voice, data, image, and video signals over high-speed networks. Many of the new broadband services may use Asynchronous Transfer Mode (ATM) – a fast packet-

switching technique using short, fixed-length packets called cells. Asynchronous Transfer Mode multiplexes a service into cells that may be combined and routed as necessary. Because of the capacity and flexibility that it offers, SDH is a logical transport mechanism for ATM. In principle, ATM is quite similar to other packet-switching techniques; however, the detail of ATM operation is somewhat

different. Each ATM cell is made up of 53 octets, or bytes (see Figure 29). Of these, 48 octets make up the user-information field and five octets make up the header. The cell header identifies the “virtual path” to be used in routing the cell through the network. The virtual path defines the connections through which the cell is routed to reach its destination (see Figure 30).

An ATM-based network is bandwidth-flexible, which allows handling of a dynamically variable mixture of services at different bandwidths. ATM also easily accommodates traffic of variable speeds. An example of a service that realizes the benefits of a variable-rate interface is that of a video service, where video can be digitally coded and packetised within ATM cells.

The rate at which cells can be transmitted through the network is dependent upon the physical layer of the network used for transport of the cells. The interface rate presented to the user may vary between a minimum and maximum rate, which ensures a much more efficient use of the bandwidth made available to the end user.

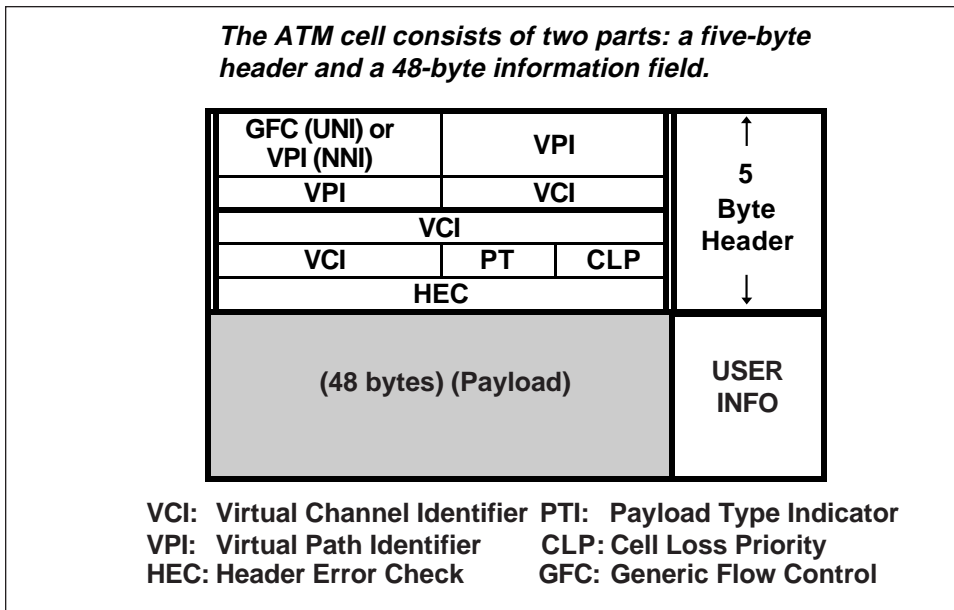

Figure 29. ATM cell structure.

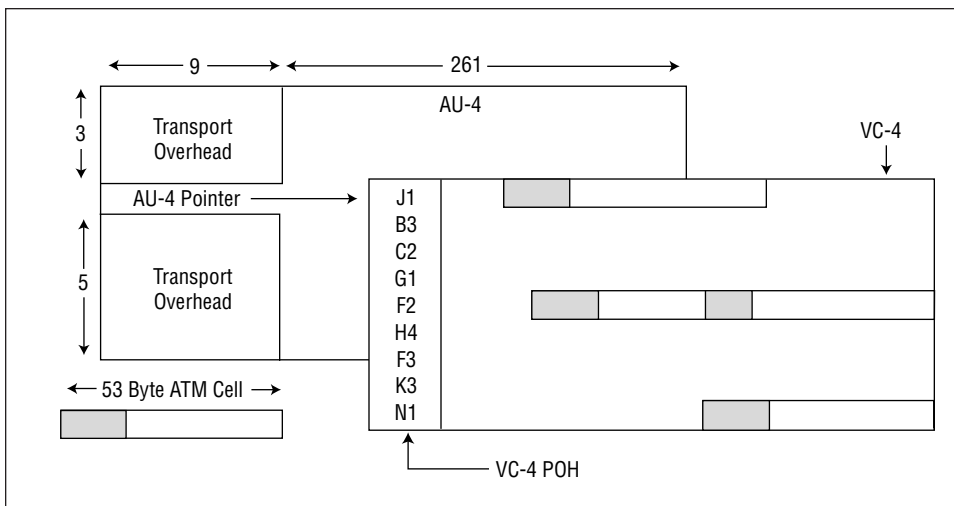

Figure 30. ATM SDH mapping.

# SONET Reference

Transmission standards in the U.S., Canada, Korea, Taiwan, and Hong Kong (ANSI) and the rest of the world (ITU-T) evolved from different basic-rate signals in the non-synchronous hierarchy. ANSI Time Division Multiplexing (TDM) combines twenty four 64 kbit/s channels (DS0) into one 1.544 Mbit/s DS1 signal. ITU TDM multiplexes thirty 64 kbit/s channels (E0) into one 2.048 Mbit/s E1 signal (an extra two channels provide frame alignment and signalling, making 32 total).

An important issue for the ITU-T to resolve was how to efficiently accommodate both the 1.5 Mbit/s and the 2 Mbit/s non-synchronous hierarchies in a single network standard. The agreement reached specified a basic transmission rate of 51 Mbit/s for SONET and a basic rate of 155 Mbit/s for SDH.

Synchronous and non-synchronous line rates and the relationships between each are shown in Tables 13 and 14.

## SONET and SDH Hierarchies

SONET and SDH converge at SDH's 155 Mbit/s base level, defined as STM-1 or "Synchronous Transport Module-1." The base level for SONET is STS-1 (or OC-1) and is equivalent to 51.84 Mbit/s. Thus, SDH's STM-1 is equivalent to SONET's STS-3 (3 x 51.84 Mbit/s = 155.52 Mbit/s). Higher SDH rates of STM-4 (622 Mbit/s), STM-16 (2.4 Gbit/s), and STM-64 (10 Gbit/s) have also been defined.

Multiplexing is accomplished by combining – or interleaving – multiple lower-order signals (1.5 Mbit/s, 2 Mbit/s, etc.) into higher-speed circuits (51 Mbit/s, 155 Mbit/s, etc.). By changing the SONET standard from bit-interleaving to byte-interleaving, it became possible for SDH to accommodate both transmission hierarchies. This modification allows an STM-1 signal to carry multiple 1.5 Mbit/s or 2 Mbit/s signals – and multiple STM signals to be aggregated to carry higher orders of SONET or SDH tributaries.

## Further Information

Another publication from Tektronix, *SONET Telecommunications Standard Primer* reviews the SONET network standard. Copies can be requested from Tektronix offices.

**Table 13. SONET/SDH Digital Hierarchies**

SONET	Bit Rate	SDH	SONET Capacity	SDH Capacity
STS-1, OC-1	51.84 Mbit/s	STM-0	28 DS1 or 1 DS3	21 E1
STS-3, OC-3	155.52 Mbit/s	STM-1	84 DS1 or 3 DS3	63 E1 or 1 E4
STS-12, OC-12	622.08 Mbit/s	STM-4	336 DS1 or 12 DS3	252 E1 or 4 E4
STS-48, OC-48	2488.32 Mbit/s	STM-16	1344 DS1 or 48 DS3	1008 E1 or 16 E4
STS-192, OC-192	9953.28 Mbit/s	STM-64	5376 DS1 or 192 DS3	4032 E1 or 64 E4
STS-768, OC-768	39812.12 Mbit/s	STM-256	21504 DS1s or 768 DS3s	16128 E1 or 256 E4

**Note:** Although an SDH STM-1 has the same bit rate as the SONET STS-3, the two signals contain different frame structures.

STM = Synchronous Transport Module (ITU-T)

STS = Synchronous Transport Signal (ANSI)

OC = Optical Carrier (ANSI)

**Table 14. Non-Synchronous Digital Hierarchies**

Signal	ANSI Rate		ITU Rate		
	Digital Bit Rate	Channels	Signal	Digital Bit Rate	Channels
DS0	64 kbit/s	1 DS0	E0	64 kbit/s	64 kbit/s
DS1	1.544 Mbit/s	24 DS0	E1	2.048 Mbit/s	32 E0
DS2	6.312 Mbit/s	96 DS0	E2	8.448 Mbit/s	128 E0
DS3	44.736 Mbit/s	28 DS1	E3	34.368 Mbit/s	16 E1
	not defined		E4	139.264 Mbit/s	64 E1



# Glossary

**Add/Drop** – The process where a part of the information carried in a transmission system is extracted (dropped) at an intermediate point and different information is inserted (added) for subsequent transmission. The remaining traffic passes straight through the multiplexer without additional processing.

**Add/Drop Multiplexer (ADM)** – A multiplexer capable of extracting and inserting lower-rate signals from a higher-rate multiplexed signal without completely demultiplexing the signal.

**Administrative Unit (AU)** – An Administrative Unit is the information structure which provides adaptation between the Higher-Order path layer and the Multiplex Section layer. The Virtual Container (VC) plus the pointers (H1, H2, H3 bytes) is called the Administrative Unit (AU).

**AIS (Alarm Indication Signal)** – A code sent downstream indicating an upstream failure has occurred.

**AMI** – Alternate Mark Inversion. The line-coding format in transmission systems where successive ones (marks) are alternatively inverted (sent with polarity opposite that of the preceding mark).

**ANSI** – American National Standards Institute. A standards-setting, non-government organization, which develops and publishes standards for “voluntary” use in the United States.

**Asynchronous** – A network where transmission system payloads are not synchronized and each network terminal runs on its own clock.

**Asynchronous Transfer Mode (ATM)** – A multiplexing/switching technique in which information is organized into fixed-length cells with each cell consisting of an identification header field and an information field. The transfer mode is asynchronous in the sense that the use of the cells depends on the required or instantaneous bit rate.

**Attenuation** – Reduction of signal magnitude or signal loss, usually expressed in decibels.

**Automatic Protection Switching (APS)** – The ability of a network element to detect a failed working line and switch the service to a spare (protection) line. 1+1 APS pairs a protection line with each working line. 1:N APS provides one protection line for every N working lines.

**Backhauling** – Cumbersome traffic management technique used to reduce the expense of multiplexing/demultiplexing.

**Bandwidth** – Information-carrying capacity of a communication channel. Analog bandwidth is the range of signal frequencies that can be transmitted by a communication channel or network.

**Bi-directional** – Operating in both directions. Bi-directional APS allows protection switching to be initiated by either end of the line.

**Binary N-Zero Suppression (BNZS)** – Line coding system that replaces N number of zeros with a special code to maintain pulse density required for clock recovery. N is typically 3, 6, or 8.

**BIP-8 (Bit Interleaved Parity-8)** – A method of error checking in SDH which allows in-service performance monitoring. For example, a BIP-8 creates eight-bit (one-byte) groups, then does a parity check for each of the eight bit positions in the byte.

**B-ISDN (Broadband Integrated Services Digital Network)** – A single ISDN network which can handle voice, data, and eventually video services.

**Bit** – One binary digit; a pulse of data.

## Don't Confuse The Terms!

Three sets of terms are often used interchangeably to describe SDH processes. However, it's important to recognize that these terms are not equivalent; each has a distinct meaning:

**Add/Drop** – The process where a part of the information carried in a transmission system is extracted (dropped) at an intermediate point and different

information is inserted (added) for subsequent transmission. The remaining traffic passes straight through the multiplexer without additional processing.

**Map/Demap** – A term for multiplexing, implying more visibility inside the resultant multiplexed bit stream than available with conventional asynchronous techniques.

**Multiplex/Demultiplex** – Multiplex (MUX) allows the transmission of two or more signals over a single channel. Demultiplex (DEMUX) is the process of separating two or more signals previously combined by compatible multiplexing equipment to recover signals combined within it and for restoring the distinct individual channels of the signals.

**Bit Error Rate (BER)** – The number of bit errors detected in a unit of time, usually one second. Bit Error rate (BER) is calculated with the formula:

$$BER = \frac{\text{errored bits received}}{\text{total bits sent}}$$

**Block Error rate (BLER)** – One of the underlying concepts of error performance is the notion of Errored Blocks; i.e., blocks in which one or more bits are in error. A block is a set of consecutive bits associated with the path or section monitored by means of an Error Detection Code (EDC), such as Bit Interleaved Parity (BIP). Block Error rate (BLER) is calculated with the formula:

$$BLER = \frac{\text{errored blocks received}}{\text{total blocks sent}}$$

**Bit-Interleaved Parity (BIP)** – A parity check that groups all the bits in a block into units (such as byte), then performs a parity check for each bit position in the group.

**Bit-Stuffing** – In asynchronous systems, a technique used to synchronise asynchronous signals to a common rate before multiplexing.

**Bits per second (bit/s)** – The number of bits passing a point every second. The transmission rate for digital information.

**Broadband** – Services requiring over 2 Mbit/s transport capacity.

**CCITT** – Former name of ITU.

**Channel** – The smallest subdivision of a circuit that provides a type of communication service; usually a path with only one direction.

**Circuit** – A communications path or network; usually a pair of channels providing bi-directional communication.

**Circuit Switching** – Basic switching process whereby a circuit between two users is opened on demand and maintained for their exclusive use for the duration of the transmission.

**Coding Violation (CV)** – A transmission error detected by the difference between the transmitted line code and that expected at the receive end by the logical coding rules.

**Concatenation** – The linking together of various data structures, for example two channels joined to form a single channel. In SDH, a number (M) of TUs can be linked together to produce a concatenated container, M times the size of the TU. An example of this is the concatenation of five TU-2s to carry a 32 Mbit/s video signal, known as VC-2-5c. Once assembled, any concatenated VC structure is multiplexed, switched, and transported through the network as a single entity.

**Cyclic Redundancy Check (CRC)** – A technique for using overhead bits to detect transmission errors.

**Data Communications Channel (DCC)** – Data channels in SDH that enable OAM communications between intelligent controllers and individual network nodes as well as inter-node communications.

**Defect** – A limited interruption in the ability of an item to perform a required function. Persistence of a defect can cause a failure.

**Demultiplex (DEMUX)** – To separate two or more signals previously combined by compatible multiplexing equipment to recover signals combined within it and for restoring the distinct individual channels of the signals.

**Dense Wavelength Division Multiplexing (DWDM)** – DWDM is the higher capacity version of WDM, which is a means of increasing the capacity of fibre-optic data transmission systems through the multiplexing of multiple wavelengths of light. Commercially available DWDM systems support the multiplexing of from 8 to 40 wavelengths of light.

**Digital Cross-connect (DCS)** – An electronic cross-connect which has access to lower-rate channels in higher-rate multiplexed signals and can electronically rearrange (cross-connect) those channels.

**Digital Signal** – An electrical or optical signal that varies in discrete steps. Electrical signals are coded as voltages, optical signals are coded as pulses of light.

**ETSI (European Telecommunications Standards Institute)** – Organization responsible for defining and maintaining European standards, including SDH.

**Failure** – A termination of the ability of an item to perform a required function. A failure is caused by the persistence of a defect.

**FEBE (Far End Block Error)** – See Remote Error Indication (REI).

**FERF (Far End Receive Failure)** – See Remote Defect Indication (RDI).

**Fixed Stuff** – A bit or byte whose function is reserved. Fixed stuff locations, sometimes called reserved locations, do not carry overhead or payload.

**Floating Mode** – A tributary mode that allows the synchronous payload to begin anywhere in the VC. Pointers identify the starting location of the LO-VC. LO-VCs in different multiframes may begin at different locations.

**Framing** – Method of distinguishing digital channels that have been multiplexed together.

**Frequency** – The number of cycles of periodic activity that occur in a discrete amount of time.

**Grooming** – Consolidating or segregating traffic for efficiency.

**HDB3** – High Density Bipolar 3. A bipolar coding method that does not allow more than three consecutive zeros.



**ITU (International Telecommunication Union)** – An agency of the United Nations responsible for the regulation, standardization, coordination, and development of international telecommunications as well as the harmonization of national policies. It functions through international committees of telecommunications administrations, operators, manufacturers, and scientific/industrial organizations.

**Jitter** – The short-term variations of the significant instants of a timing signal from their ideal positions in time (where short term implies that these variations are of frequency greater than or equal to 10 Hz).

**Locked Mode** – A virtual tributary mode that fixes the starting location of the VC. Locked mode has less pointer processing than floating mode.

**Map/Demap** – A term for multiplexing, implying more visibility inside the resultant multiplexed bit stream than available with conventional asynchronous techniques.

**Mapping** – The process of associating each bit transmitted by a service into the SDH payload structure that carries the service. For example, mapping an E1 service into an SDH VC-12 associates each bit of the E1 with a location in the VC-12.

**Multiframe** – Any structure made up of multiple frames. SDH has facilities to recognize multiframe at the E1 level and at the VC-N level.

**Multiplex Section Alarm Indication Signal (MS-AIS)** – MS-AIS is generated by Section Terminating Equipment (STE) upon the detection of a Loss of Signal or Loss of Frame defect, on an equipment failure. MS-AIS maintains operation of the downstream regenerators, and therefore prevents generation of unnecessary alarms. At the same time, data and orderwire communication is retained with the downstream equipment.

**Multiplex Section Remote Defect Indication (MS-RDI)** – A signal returned to the transmitting equipment upon detecting a Loss of Signal, Loss of Frame, or MS-AIS defect. MS-RDI was previously known as Multiplex Section FERF.

**Multiplex Section Overhead (MSOH)** – 18 bytes of overhead accessed, generated, and processed by MS terminating equipment. This overhead supports functions such as locating the payload in the frame, multiplexing or concatenating signals, performance monitoring, automatic protection switching, and line maintenance.

**Multiplex (MUX)** – To transmit two or more signals over a single channel.

**Multiplexer** – A device for combining several channels to be carried by a single physical channel.

**Narrowband** – Services requiring up to 2 Mbit/s transport capacity.

**Network Element (NE)** – Any device which is part of an SDH transmission path and serves one or more of the section, line and path-terminating functions.

In SDH, the five basic network elements are:

- Add/drop multiplexer
- Broadband digital cross-connect
- Wideband digital cross-connect
- Flexible multiplexer
- Regenerator

**OAM** – Operations, Administration, and Maintenance. Also called OAM&P.

**OAM&P (Operations, Administration, Maintenance, and Provisioning)** – Provides the facilities and personnel required to manage a network.

**Optical Amplifier** – A device to amplify an optical signal without converting the signal from optical to electrical and back again to optical energy. The two most common optical amplifiers are erbium-doped fibre amplifiers (EDFAs), which amplify with a laser pump diode and a section of erbium-doped fibre, and semiconductor laser amplifiers.

**Orderwire** – A dedicated voice channel used by installers to expedite the provisioning of lines.

**OS (Operations System)** – Sophisticated applications software that manages operation of the entire network.

**OSI Seven-layer Model** – A standard architecture for data communications. Layers define hardware and software required for multi-vendor information processing equipment to be mutually compatible. The seven layers from lowest to highest are: physical, link, network, transport, session, presentation, and application.

**Overhead** – Extra bits in a digital stream used to carry information besides traffic signals. Orderwire, for example, would be considered overhead information.

**Packet Switching** – An efficient method for breaking down and handling high-volume traffic in a network. A transmission technique that segments and routes information into discrete units. Packet switching allows for efficient sharing of network resources as packets from different sources can all be sent over the same channel in the same bitstream.

**Parity Check** – An error-checking scheme which examines the number of transmitted bits in a block which hold the value of “one.” For even parity, an overhead parity bit is set to either one or zero to make the total number of transmitted ones in the data block plus parity bit an even number. For odd parity, the parity bit is set to make the total number of ones in the block an odd number.

**Path** – A logical connection between a point where a service in a VC is multiplexed to the point where it is demultiplexed.

**Path Overhead (POH)** – Overhead accessed, generated, and processed by path-terminating equipment.

**Path Terminating Equipment (PTE)** – Network elements such as fibre optic terminating systems which can access, generate, and process Path Overhead.

**Payload** – The portion of the SDH signal available to carry service signals such as E1 and E3. The contents of a VC.

**Payload Pointer** – Indicates the beginning of a Virtual Container.

**Payload Capacity** – The number of bytes the payload of a single frame can carry.

**Plesiochronous** – A network with nodes timed by separate clock sources with almost the same timing.

**Pointer** – A part of the SDH overhead that locates a floating payload structure. AU-N pointers locate the payload. TU-M pointers locate floating mode tributaries. All SDH frames use AU pointers; only floating mode virtual containers use TU pointers.

**POP (Point-of-Presence)** – A point in the U.S. network where inter-exchange carrier facilities meet with access facilities managed by telephone companies or other service providers.

**PRC (Primary Reference Clock)** – In a synchronous network, all the clocks are traceable to one highly stable reference supply, the Primary Reference Clock (PRC). The accuracy of the PRC is better than  $\pm 1$  in  $10^{11}$  and is derived from a cesium atomic standard.

**Remote Alarm Indication (RAI)** – A code sent upstream on an En circuit as a notification that a failure condition has been declared downstream. (RAI signals were previously referred to as Yellow signals.)

**Remote Defect Indication (RDI)** – A signal returned to the transmitting Terminating Equipment when the receiving Terminating Equipment detects a Loss of Signal, Loss of Frame, or AIS defect. RDI was previously known as Far End Receive Failure (FERF).

**Remote Error Indication (REI)** – An indication returned to a transmitting node (source) that an errored block has been detected at the receiving node (sink). REI was previously known as Far End Block Error (FEBE).

**Remote Failure Indication (RFI)** – A failure is a defect that persists beyond the maximum time allocated to the transmission system protection mechanisms. When this situation occurs, an RFI is sent to the far end and will initiate a protection switch if this function has been enabled.

**Regenerator** – Device that restores a degraded digital signal for continued transmission; also called a repeater.

**SDH (Synchronous Digital Hierarchy)** – The ITU-defined international networking standard whose base transmission level is 155 Mbit/s (STM-1). SDH standards were first published in 1989 to address interworking between the ITU and ANSI transmission hierarchies.

**SEC (Synchronous Equipment Clock)** – G.813 slave clock contained within an SDH network element.

**Section** – The span between two SDH network elements capable of accessing, generating, and processing only SDH Section overhead.

**Section Overhead** – Nine columns of SDH overhead accessed, generated, and processed by section terminating equipment. This overhead supports functions such as framing the signal and performance monitoring.

**Section Terminating Equipment (STE)** – Equipment that terminates the SDH Section layer. STE interprets and modifies or creates the Section Overhead.

**Slip** – An overflow (deletion) or underflow (repetition) of one frame of a signal in a receiving buffer.

**SONET (Synchronous Optical Network)** – A standard for optical transport in the United States, Canada, Korea, and Hong Kong that defines optical carrier levels and their electrically equivalent synchronous transport signals. SONET allows for a multi-vendor environment and positions the network for transport of new services, synchronous networking, and enhanced OAM&P.

**SSM (Synchronisation Status Message)** – Bits 5 to 8 of SDH overhead byte S1 are allocated for Synchronisation Status Messages. For further details on the assignment of bit patterns for byte S1, see the section of this primer on Multiplex Section Overhead.

**Stuffing** – See bit-stuffing.

**Synchronous** – A network where transmission system payloads are synchronised to a master (network) clock and traceable to a reference clock. A network where all clocks have the same long term accuracy under normal operating conditions.

**Synchronisation Supply Unit (SSU)** – A G.812 network equipment clock.

**Synchronous Transport Module (STM)** – A structure in the SDH transmission hierarchy. STM-1 is SDH's base-level transmission rate equal to 155.52 Mbit/s. Higher rates of STM-4, STM-16, and STM-64 are also defined.

**Tributary Unit (TU)** – A Tributary Unit is an information structure which provides adaptation between the Lower-Order path layer and the Higher-Order path layer. It contains the Virtual Container (VC) plus a tributary unit pointer.

**Tributary Unit Group (TUG)** – Contains several Tributary Units.

**Virtual Container (VC)** – A signal designed for transport and switching of sub-SDH payloads.

**Wander** – The long-term variations of the significant instants of a digital signal from their ideal position in time (where long term implies that these variations are of frequency less than 10 Hz).

**Wavelength Division Multiplexing (WDM)** – WDM is a means of increasing the capacity of fibre-optic data transmission systems through the multiplexing of multiple wavelengths of light. WDM systems support the multiplexing of as many as four wavelengths.

**Yellow Signal** – See Remote Alarm Indication (RAI).



---

## SDH Reference Materials

### ITU-T:

- **G.701** – Vocabulary of digital transmission and multiplexing and PCM terms
- **G.702** – Digital Hierarchy bit rates
- **G.703** – Physical/electrical characteristics of hierarchical digital interfaces
- **G.704** – Synchronous frame structures used at 1544, 6312, 2048, 8448, and 44736 kbit/s hierarchical levels
- **G.706** – Frame alignment and cyclic redundancy check (CRC) procedures relating to basic frame structures defined in Recommendation G.704
- **G.707** – Network Node Interface for the SDH
- **G.772** – Protected monitoring points provided on digital transmission systems
- **G.780** – Vocabulary of terms for SDH networks and equipment
- **G.783** – Characteristics of SDH equipment functional blocks
- **G.784** – SDH management
- **G.803** – Architecture of transport networks based on the SDH
- **G.823** – Control of jitter and wander in PDH systems
- **G.825** – Control of jitter and wander in SDH systems
- **G.826** – Error performance parameters and objectives for international, constant bit rate digital paths at or above the primary rate
- **G.827** – Availability parameters and objectives for path elements of international constant bit-rate digital paths at or above the primary rate
- **G.831** – Management capabilities of transport network based on SDH
- **G.841** – Types and characteristics of SDH network protection architectures
- **G.861** – Principles and guidelines for the integration of satellite and radio systems in SDH
- **G.957** – Optical interfaces for equipment and systems relating to the SDH
- **G.958** – Digital line systems based on SDH for use on optical fibre cables
- **I.432** – B-ISDN user-network interface – Physical layer specification
- **M.2100** – Performance limits for bringing-into-service and maintenance of international digital paths, sections, and transmission systems
- **M.2101** – Performance limits for BIS and maintenance of SDH paths and multiplex sections
- **O.150** – General requirements for instrumentation for performance measurements on digital transmission equipment
- **O.172** – Jitter and wander measuring equipment for digital systems which are based on the Synchronous Digital Hierarchy (SDH)
- **O.181** – Equipment to assess error performance on STM-N interfaces
- **F.750 (ITU-R)** – Architectures and functional aspects of radio-relay systems for SDH-based networks





### For further information, contact Tektronix:

**Worldwide Web:** For the most up-to-date product information, visit our web site at [www.tektronix.com](http://www.tektronix.com).

**ASEAN Countries** (65) 356-3900; **Australia & New Zealand** 61 (2) 9888-0100; **Austria, Central Eastern Europe, Greece, Turkey, Malta, & Cyprus** +43 2236 8092 0; **Belgium** +32 (2) 715 89 70; **Brazil and South America** 55 (11) 3741-8360; **Canada** 1 (800) 661-5625; **Denmark** +45 (44) 850 700; **Finland** +358 (9) 4783 400; **France & North Africa** +33 1 69 86 81 81; **Germany** + 49 (221) 94 77 400; **Hong Kong** (852) 2585-6688; **India** (91) 80-2275577; **Italy** +39 (2) 25086 501; **Japan (Sony/Tektronix Corporation)** 81 (3) 3448-3111; **Mexico, Central America, & Caribbean** 52 (5) 666-6333; **The Netherlands** +31 23 56 95555; **Norway** +47 22 07 07 00; **People's Republic of China** 86 (10) 6235 1230; **Republic of Korea** 82 (2) 528-5299; **South Africa** (27 11) 651-5222; **Spain & Portugal** +34 91 372 6000; **Sweden** +46 8 477 65 00; **Switzerland** +41 (41) 729 36 40; **Taiwan** 886 (2) 2722-9622; **United Kingdom & Eire** +44 (0) 1344 392000; **USA** 1 (800) 426-2200.

**From other areas, contact:** Tektronix, Inc. Export Sales, P.O. Box 500, M/S 50-255, Beaverton, Oregon 97077-0001, USA 1 (503) 627-6877.



Copyright © 2000, Tektronix, Inc. All rights reserved. Tektronix products are covered by U.S. and foreign patents, issued and pending. Information in this publication supersedes that in all previously published material. Specification and price change privileges reserved. TEKTRONIX and TEK are registered trademarks of Tektronix, Inc. All other trade names referenced are the service marks, trademarks, or registered trademarks of their respective companies.