

MODEL **AJ-1214 AM-FM Stereo Tuner**

# **HEATHKIT<sup>®</sup>**

## **ASSEMBLY MANUAL**

HEATH COMPANY • BENTON HARBOR, MICHIGAN



PRICE \$2.00



Copyright © 1972  
Heath Company  
All rights reserved

595-1425-02

Assembly  
and  
Operation  
of the



**AM-FM STEREO TUNER**  
MODEL AJ-1214



HEATH COMPANY  
BENTON HARBOR, MICHIGAN 49022



## TABLE OF CONTENTS

INTRODUCTION . . . . .	3
PARTS LIST . . . . .	5
<b>STEP-BY-STEP ASSEMBLY</b>	
Circuit Boards . . . . .	9
Chassis . . . . .	22
Alternate Line Voltage Wiring . . . . .	26
Shield and Label Installation . . . . .	27
Circuit Board Wiring . . . . .	28
AM Antenna . . . . .	30
Dial Installation . . . . .	32
<b>ADJUSTMENTS</b>	
FM Adjustments . . . . .	35
AM Adjustments . . . . .	36
FINAL ASSEMBLY . . . . .	39
<b>INSTALLATION</b>	
Connecting the Tuner to your System . . . . .	41
OPERATION . . . . .	45
<b>IN CASE OF DIFFICULTY</b>	
General . . . . .	47
Troubleshooting Charts . . . . .	48
<b>ALIGNMENT WITH INSTRUMENTS</b>	
FM Alignment . . . . .	51
AM Alignment . . . . .	53
SPECIFICATIONS . . . . .	55
<b>CIRCUIT DESCRIPTION</b>	
FM Circuit . . . . .	57
AM Circuit . . . . .	59
Power Supply . . . . .	59
CHASSIS PHOTOGRAPH . . . . .	60
CIRCUIT BOARD X-RAY VIEWS . . . . .	61
VOLTAGE CHARTS . . . . .	64
SCHEMATIC . . . (fold-out from page) . . . . .	67
WARRANTY . . . . .	Inside front cover
CUSTOMER SERVICE . . . . .	Inside rear cover

# INTRODUCTION

The Heathkit Model AJ-1214 Stereo Tuner is a quality Tuner that will complement any audio system. It is easy to assemble, has solid-state components that mount to the circuit boards, and it will provide you with dependable FM, AM, and FM Stereo reception.

A single knob tunes AM or FM stations with smooth flywheel action. Pushbutton switches are used to turn the Tuner on and off, to select either the AM or FM operating mode, and to allow for mono or stereo reproduction. These switches add to the fine appearance of the Tuner and make it a pleasure to operate.

Thirteen transistors, six diodes, and three integrated circuits are used in the advanced semiconductor circuitry. The preassembled FM tuning unit uses an RF field-effect transistor to provide high sensitivity and low cross modulation with no overload on strong local stations. The FM-IF circuit utilizes three integrated circuits for compact design, dependability, and best amplifying/limiting characteristics. Selectivity is provided by two ceramic filters which provide optimum stereo separation and minimum distortion.

Silicon transistors in the AM and FM circuits provide good sensitivity with good signal handling capability. The built-in AM rod antenna can be positioned for best AM reception.

The power supply circuit provides regulated DC voltage to the various Tuner circuits. This provides stable operation and improves performance. The power transformer can be wired for 120 VAC or 240 VAC 50/60 Hz operation.

Most of the components are mounted on two circuit boards and all the circuitry is easily accessible for adjustments and servicing.

The back-lighted front panel and wood side panels give the Tuner an impressive appearance that matches its high performance.

Read the "Kit Builders Guide" for complete information on unpacking, parts identification, tools, wiring, soldering, and step-by-step assembly procedures.

# PARTS PICTORIAL

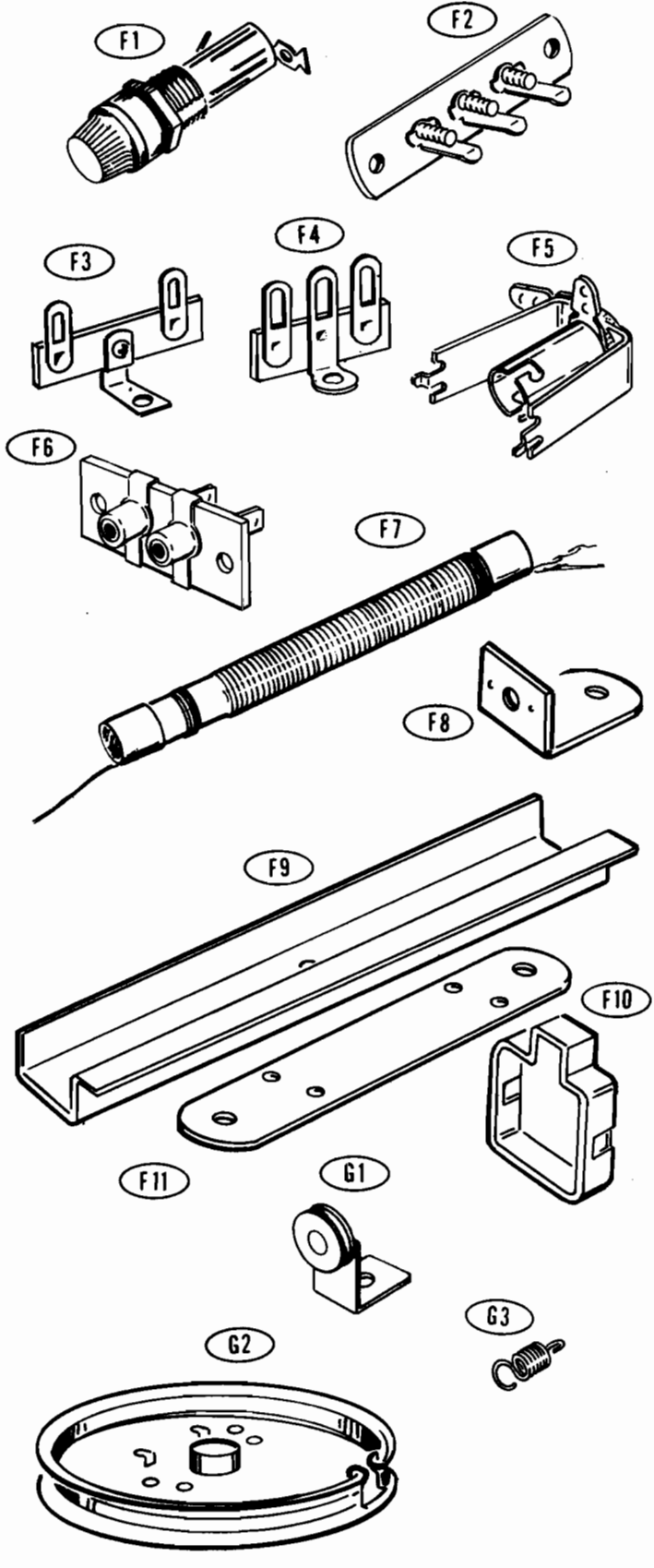
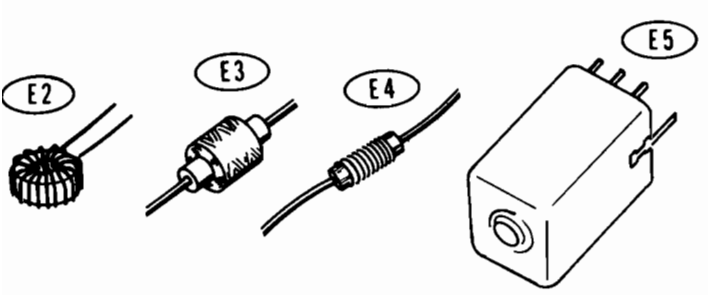
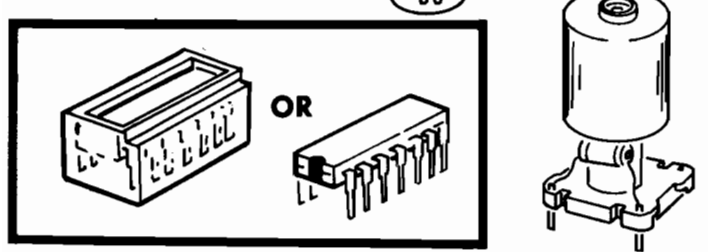
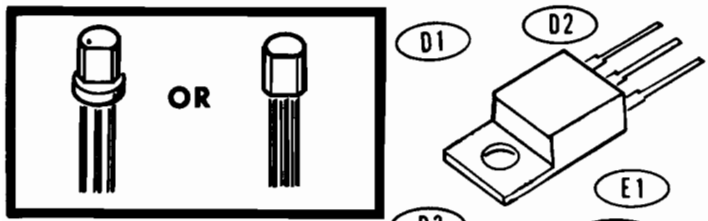
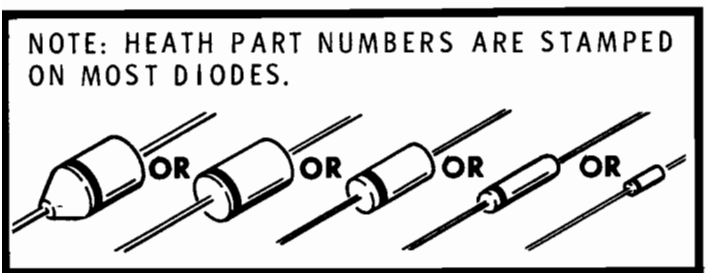
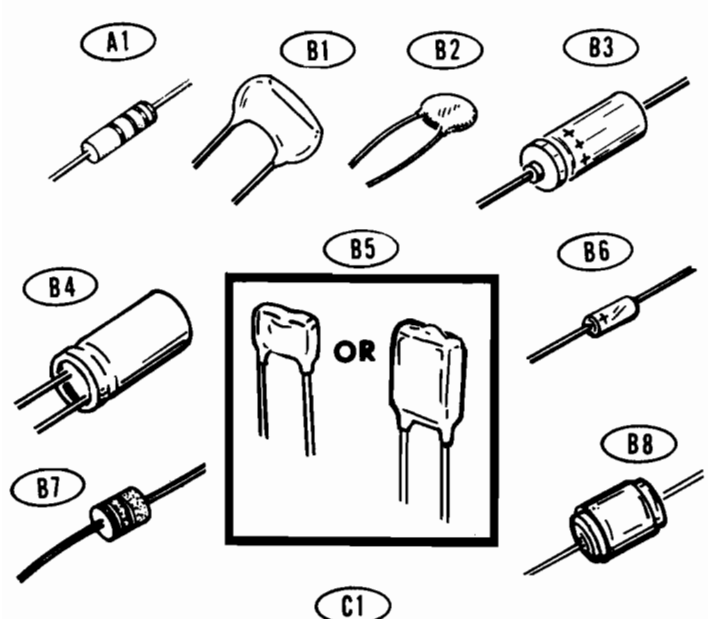

# PARTS LIST

Some parts are packaged in envelopes with their part numbers printed on the outside. After being identified, return these parts to their envelopes until they are called for in assembly steps.

To order a replacement part, use the Parts Order Form furnished with this kit. If a Parts Order Form is not available, refer to "Replacement Parts" inside the rear cover of the Manual.

Check each part against the following list. The key numbers correspond to the numbers in the Parts Pictorial (fold-out from Pages 4 and 7).

The following prices apply only on purchases from the Heath Company where shipment is to a U.S.A. destination. Add 10% (minimum 25 cents) to the price when ordering from a Heathkit Electronic Center to cover local sales tax, postage, and handling. Outside the U.S.A. parts and service are available from your local Heathkit source and will reflect additional transportation, taxes, duties, and rates of exchange.

KEY PART No.	KEY PART No.	PARTS Per Kit	DESCRIPTION	PRICE Each
<b>RESISTORS (All resistors are 1/2-watt)</b>				
A1	1-3	3	100 $\Omega$ (brown-black-brown)	.10
A1	1-137	1	200 $\Omega$ (red-black-brown)	.10
A1	1-4	5	330 $\Omega$ (orange-orange-brown)	.10
A1	1-63	1	510 $\Omega$ (green-brown-brown)	.10
A1	1-9	5	1000 $\Omega$ (brown-black-red)	.10
A1	1-80	2	1200 $\Omega$ (brown-red-red)	.10
A1	1-11	3	1500 $\Omega$ (brown-green-red)	.10
A1	1-144	1	1800 $\Omega$ (brown-gray-red)	.10
A1	1-57	2	2200 $\Omega$ (red-red-red)	.10
A1	1-13	3	2700 $\Omega$ (red-violet-red)	.10
A1	1-14	1	3300 $\Omega$ (orange-orange-red)	.10
A1	1-16	2	4700 $\Omega$ (yellow-violet-red)	.10
A1	1-18	1	5600 $\Omega$ (green-blue-red)	.10
A1	1-19	3	6800 $\Omega$ (blue-gray-red)	.10

KEY PART No.	KEY PART No.	PARTS Per Kit	DESCRIPTION	PRICE Each
<b>Resistors (cont'd.)</b>				
A1	1-114	3	8200 $\Omega$ (gray-red-red)	.20
A1	1-20	3	10 k $\Omega$ (brown-black-orange)	.10
A1	1-21	2	15 k $\Omega$ (brown-green-orange)	.10
A1	1-25	2	47 k $\Omega$ (yellow-violet-orange)	.10
A1	1-60	2	68 k $\Omega$ (blue-gray-orange)	.10
A1	1-104	1	100 k $\Omega$ (brown-black-yellow)	.10
A1	1-107	3	150 k $\Omega$ (brown-green-yellow)	.10
A1	1-126	1	180 k $\Omega$ (brown-gray-yellow)	.10
A1	1-77	3	390 k $\Omega$ (orange-white-yellow)	.10
A1	1-142	1	560 k $\Omega$ (green-blue-yellow)	.10
A1	1-34	2	680 k $\Omega$ (blue-gray-yellow)	.10
A1	1-37	1	2.2 M $\Omega$ (red-red-green)	.10

KEY PART No.	PARTS No.	Per Kit	DESCRIPTION	PRICE Each
--------------	-----------	---------	-------------	------------

**CAPACITORS****Mica**

B1	20-149	1	150 pF	.25
B1	20-115	2	300 pF	.25
B1	20-167	1	620 pF	.40

**Disc**

B2	21-3	1	10 pF	.10
B2	21-7	1	33 pF	.10
B2	21-75	1	100 pF	.10
B2	21-56	1	470 pF	.10
B2	21-159	1	510 pF	.15
B2	21-140	1	.001 $\mu$ F	.10
B2	21-82	2	.02 $\mu$ F	.10
B2	21-143	11	.05 $\mu$ F	.20
B2	21-95	8	.1 $\mu$ F	.15
B2	21-71	1	.001 $\mu$ F 1.4 kV	.10

**Electrolytic**

B3	25-215	1	2 $\mu$ F	.55
B3	25-199	1	500 $\mu$ F	.60
B4	25-257	9	10 $\mu$ F	.25
B4	25-248	5	100 $\mu$ F	.40

**Mylar\***

B5	27-69	2	.0091 $\mu$ F	.40
B5	27-47	1	.1 $\mu$ F	.20
B5	27-60	4	.22 $\mu$ F	.25
B5	27-86	1	.27 $\mu$ F	.40
B5	27-117	1	.47 $\mu$ F	.30

**Other Capacitors**

B6	25-197	1	1 $\mu$ F tantalum	.70
B7	28-3	1	.56 pF phenolic (green-blue-gray)	.10
B8	29-8	2	3300 pF polystyrene	.15

**DIODES**

C1	56-26	1	1N191 germanium (brown-white-brown)	.25
C1	56-56	2	1N4149 silicon	.20
C1	56-67	1	VR10A zener	1.10
C1	57-65	2	1N4002 silicon	.20

**TRANSISTORS AND INTEGRATED CIRCUITS**

NOTE: Transistors and integrated circuits are marked for identification in one of the following four ways:

1. Part number.

KEY PART No.	PARTS No.	Per Kit	DESCRIPTION	PRICE Each
--------------	-----------	---------	-------------	------------

**Transistors and Integrated Circuits (cont'd.)**

2. Transistor or integrated circuit type number. (In integrated circuits, this refers to the numbers only; the letters may be different.)
3. Part number and transistor type number.
4. Part number with a transistor type number other than the one listed.

D1	417-83	1	L842 transistor	.75
D1	417-84	1	E843 transistor	.70
D1	417-85	1	E844 transistor	.70
D1	417-118	5	2N3393 transistor	.40
D1	417-91	2	2N5232A transistor	.85
D1	417-213	1	2N5249A transistor	1.30
D1	417-201	1	X29A829 transistor	.50
D2	417-175	1	2N5294 transistor	1.45
D3	442-28	2	MC1357P integrated circuit	2.10
D3	442-46	1	MC1310 integrated circuit	5.00

**COILS-CHOKES-TRANSFORMERS**

E1	40-956	2	Coil	.75
E1	40-957	2	Coil	.80
E2	40-961	1	Toroid coil	.60
E3	45-47	1	Choke	.35
E4	45-57	1	Choke	.30
E5	52-89	1	455 kHz IF transformer	1.30
E5	52-90	1	455 kHz IF transformer	1.00
E5	52-154	1	10.7 MHz IF transformer	.70
E5	52-157	1	Oscillator transformer	.80
E5	52-158	1	RF transformer	.70
	54-805	1	Power transformer	5.00

**FUSEHOLDER-TERMINAL STRIPS-SOCKETS**

F1	423-2	1	Fuseholder (with hardware)	.60
F2	431-8	1	3-screw terminal strip	.10
F3	431-41	1	2-lug terminal strip	.10
F4	431-10	1	3-lug terminal strip	.10
F5	434-171	4	Lamp socket	.20
F6	434-174	1	Dual phono socket	.15

**AM ANTENNA PARTS**

F7	40-1601	1	Rod antenna	2.05
F8	204-1159	1	Antenna mounting bracket	.15
	73-39	1	Foam tape	.01/ft
F9	214-168	2	Antenna housing	.15
F10	440-13	2	Antenna housing end cap	.10
F11	266-297	2	Antenna pivot arm	.25

KEY PART		PARTS Per Kit	DESCRIPTION	PRICE Each	KEY PART		DESCRIPTION	PRICE Each	
No.	No.				No.	No.			
<b>DIAL PARTS</b>					<b>Wire-Sleeving (cont'd.)</b>				
G1	100-622	2	Pulley assembly	.15	344-76	1	White-blue wire	.05/ft	
G2	100-1610	1	Dial pulley	.25	346-19	2	Sleeving	.05/ft	
	100-1093	1	Dial cord	.70	347-2	1	300 $\Omega$ twin lead	.05/ft	
G3	258-85	1	Spring	.10	<b>CHASSIS PARTS</b>				
G4	454-19	1	Flywheel assembly	2.15	L1	203-1415	1	Top panel	3.20
G5	455-44	1	Snap-in bearing	.10	L2	203-1422	1	Top trim strip	1.55
G6	462-365	1	Knob	.50	L3	206-560	1	Light shield	.40
G7	463-58	1	Pointer	.10	L4	206-563	1	AC shield	.45
	446-99	1	Dial window	3.00	L5	203-1416	1	Left end	1.20
<b>HARDWARE</b>					L6	203-1414-1	1	Rear Panel	3.05
<b>#6 Hardware</b>					L7	204-1838	1	Center support bracket	1.80
H1	250-170	10	#6 x 1/4" sheet metal screw	.05	L8	200-636	1	Chassis	1.90
H2	250-369	30	#6 x 1/4" <u>black</u> sheet screw	.05	L9	203-1413	1	Front panel	3.00
H3	250-416	2	6-32 x 1/4" flat head screw	.05	L10	203-1421	1	Bottom trim strip	3.35
H4	250-89	8	6-32 x 3/8" screw	.05	L11	205-883	1	Bottom plate	1.95
H5	250-162	1	6-32 x 1/2" screw	.05		94-529	2	Wood side panel	2.55
H6	250-548	4	#6 x 5/8" sheet metal screw	.05	<b>MISCELLANEOUS</b>				
H7	250-206	1	6-32 x 11/16" screw	.05	M1	10-311	1	5000 $\Omega$ control	.35
H8	252-3	10	6-32 nut	.05	M1	10-941	1	100 k $\Omega$ control	.35
H9	252-27	2	6-32 locknut	.10	M2	64-602	1	Switch assembly	4.95
H10	254-1	20	#6 lockwasher	.05		73-1	3	Small rubber grommet	.10
H11	255-169	1	#6 plastic washer	.05		73-3	1	Large rubber grommet	.10
H12	259-1	2	#6 solder lug	.05	M3	75-71	1	Line cord strain relief	.10
<b>#8 Hardware</b>					M4	261-28	4	Plastic foot	.05
J1	250-18	2	8-32 x 3/8" screw	.05	M5	354-5	4	Cable tie	.10
J2	252-4	2	8-32 nut	.05	M6	404-530-1	1	Ceramic filters (matched pair)	4.80
J3	254-2	2	#8 lockwasher	.05	M7	412-58	4	#1813 lamp	.25
<b>Control Hardware</b>					M8	421-31	1	3/16-ampere 3AG slow-blow fuse	.55
K1	252-7	1	Control nut	.05	M9	434-225	1	Integrated circuit socket	.20
K2	254-5	1	Control lockwasher	.05	M10	432-67	1	Wire nut	.10
<b>WIRE-SLEEVING</b>					M11	475-10	1	Ferrite bead	.10
	89-37	1	Line cord	.65		74-4	1	Roll of plastic tape	.35
	343-5	1	Coaxial cable	.10/ft		75-156	1	Paper insulator	.10
	344-2	1	Black stranded wire	.05/ft		110-67	1	Tuner assembly	13.50*
	344-50	1	Black wire	.05/ft		85-1164-2	1	Tuner circuit board	4.75
	344-51	1	Brown wire	.05/ft	<b>*Tuners are available at half-price plus postage on an exchange basis; the defective unit returnable after replacement is received. Tuner returned must be in repairable condition.</b>				
	344-52	1	Red wire	.05/ft					
	344-53	1	Orange wire	.05/ft					
	344-54	1	Yellow wire	.05/ft					
	344-55	1	Green wire	.05/ft					
	344-56	1	Blue wire	.05/ft					



# PARTS PICTORIAL (Continued)

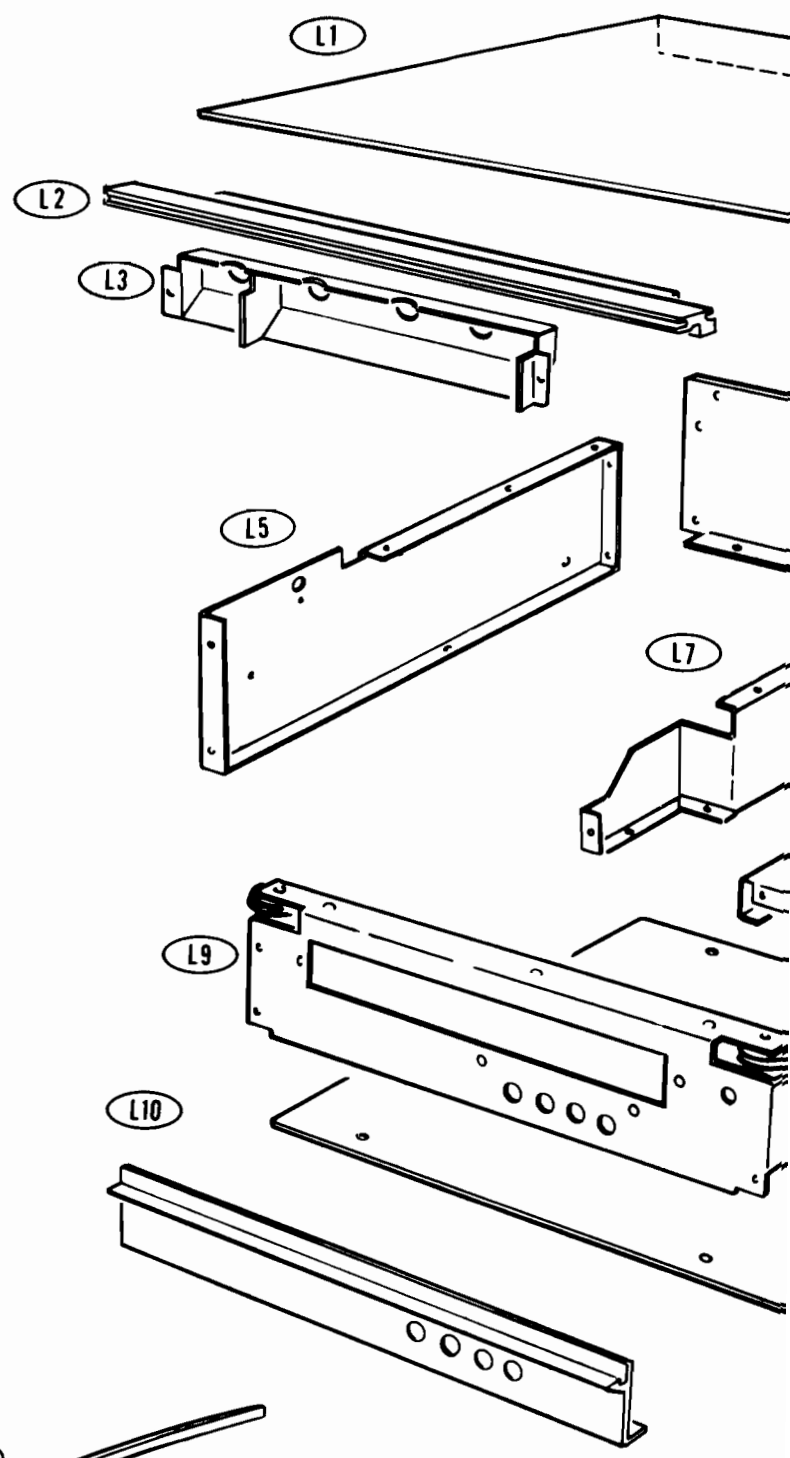
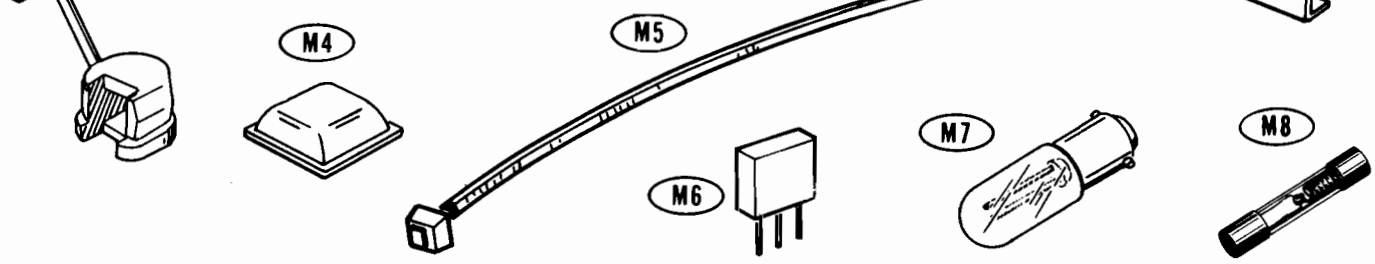
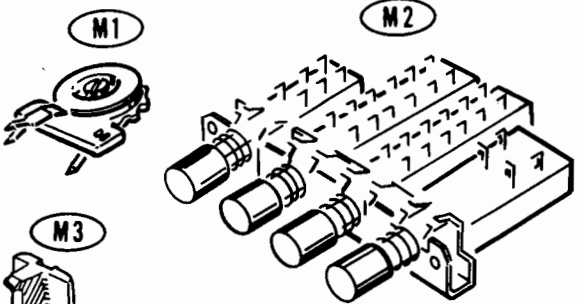
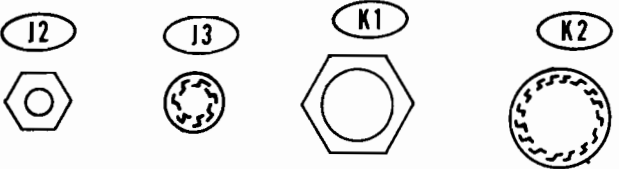
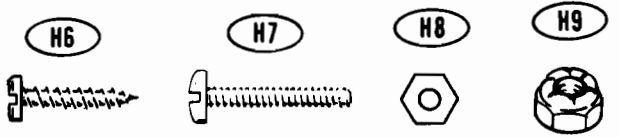
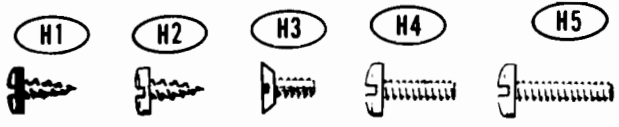
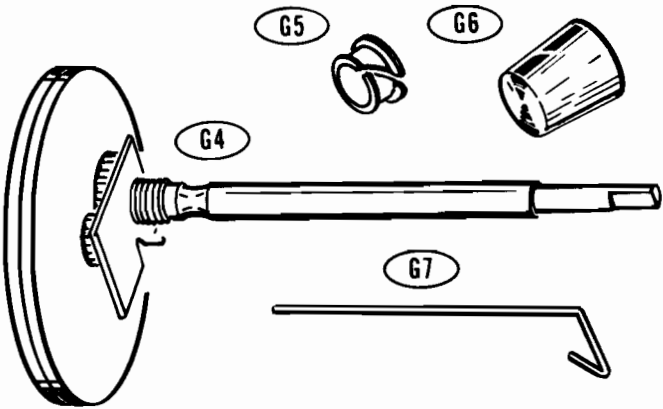

# RIAL (Continued)

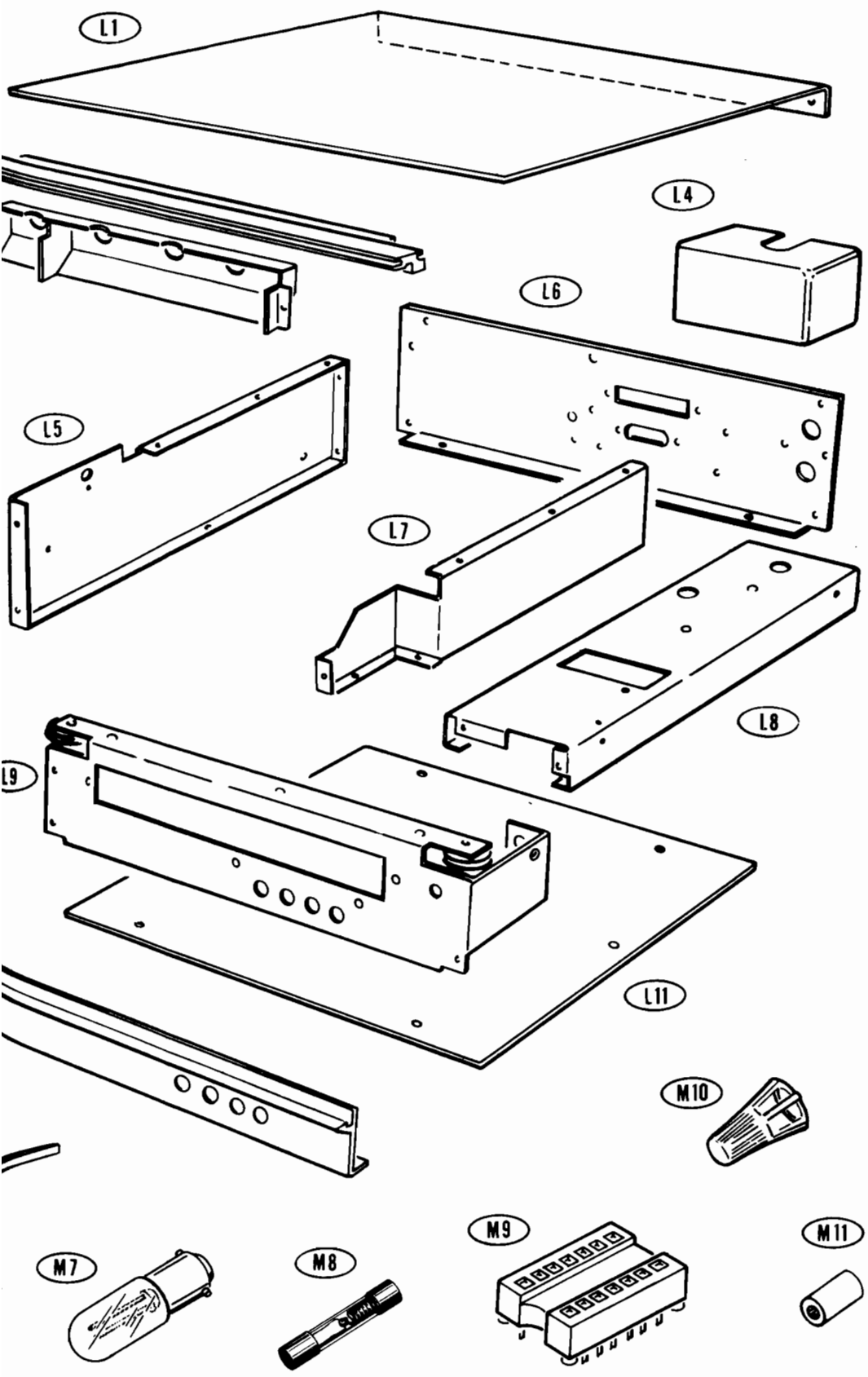

KEY PART No.	PARTS No.	PARTS Per Kit	DESCRIPTION	PRICE Each	KEY PART No.	PARTS No.	PARTS Per Kit	DESCRIPTION	PRICE Each
<b>DIAL PARTS</b>					<b>Wire-Sleeving (cont'd.)</b>				
G1	100-622	2	Pulley assembly	.15		344-76	1	White-blue wire	.05/ft
G2	100-1610	1	Dial pulley	.25		346-19	2	Sleeving	.05/ft
	100-1093	1	Dial cord	.70		347-2	1	300 Ω twin lead	.05/ft
G3	258-85	1	Spring	.10	<b>CHASSIS PARTS</b>				
G4	454-19	1	Flywheel assembly	2.15	L1	203-1415	1	Top panel	3.20
G5	455-44	1	Snap-in bearing	.10	L2	203-1422	1	Top trim strip	1.55
G6	462-365	1	Knob	.50	L3	206-560	1	Light shield	.40
G7	463-58	1	Pointer	.10	L4	206-563	1	AC shield	.45
	446-99	1	Dial window	3.00	L5	203-1416	1	Left end	1.20
<b>HARDWARE</b>					L6	203-1414-1	1	Rear Panel	3.05
<b>#6 Hardware</b>					L7	204-1838	1	Center support bracket	1.80
H1	250-170	10	#6 x 1/4" sheet metal screw	.05	L8	200-636	1	Chassis	1.90
H2	250-369	30	#6 x 1/4" <u>black</u> sheet screw	.05	L9	203-1413	1	Front panel	3.00
H3	250-416	2	6-32 x 1/4" flat head screw	.05	L10	203-1421	1	Bottom trim strip	3.35
H4	250-89	8	6-32 x 3/8" screw	.05	L11	205-883	1	Bottom plate	1.95
H5	250-162	1	6-32 x 1/2" screw	.05		94-529	2	Wood side panel	2.55
H6	250-548	4	#6 x 5/8" sheet metal screw	.05	<b>MISCELLANEOUS</b>				
H7	250-206	1	6-32 x 11/16" screw	.05	M1	10-311	1	5000 Ω control	.35
H8	252-3	10	6-32 nut	.05	M1	10-941	1	100 kΩ control	.35
H9	252-27	2	6-32 locknut	.10	M2	64-602	1	Switch assembly	4.95
H10	254-1	20	#6 lockwasher	.05		73-1	3	Small rubber grommet	.10
H11	255-169	1	#6 plastic washer	.05		73-3	1	Large rubber grommet	.10
H12	259-1	2	#6 solder lug	.05	M3	75-71	1	Line cord strain relief	.10
<b>#8 Hardware</b>					M4	261-28	4	Plastic foot	.05
J1	250-18	2	8-32 x 3/8" screw	.05	M5	354-5	4	Cable tie	.10
J2	252-4	2	8-32 nut	.05	M6	404-530-1	1	Ceramic filters (matched pair)	4.80
J3	254-2	2	#8 lockwasher	.05	M7	412-58	4	#1813 lamp	.25
<b>Control Hardware</b>					M8	421-31	1	3/16-ampere 3AG slow-blow fuse	.55
K1	252-7	1	Control nut	.05	M9	434-225	1	Integrated circuit socket	.20
K2	254-5	1	Control lockwasher	.05	M10	432-67	1	Wire nut	.10
<b>WIRE-SLEEVING</b>					M11	475-10	1	Ferrite bead	.10
	89-37	1	Line cord	.65		74-4	1	Roll of plastic tape	.35
	343-5	1	Coaxial cable	.10/ft		75-156	1	Paper insulator	.10
	344-2	1	Black stranded wire	.05/ft		110-67	1	Tuner assembly	13.50*
	344-50	1	Black wire	.05/ft		85-1164-2	1	Tuner circuit board	4.75
	344-51	1	Brown wire	.05/ft	*Tuners are available at half-price plus postage on an exchange basis; the defective unit returnable after replacement is received. Tuner returned must be in repairable condition.				
	344-52	1	Red wire	.05/ft					
	344-53	1	Orange wire	.05/ft					
	344-54	1	Yellow wire	.05/ft					
	344-55	1	Green wire	.05/ft					
	344-56	1	Blue wire	.05/ft					



<u>KEY PART</u>	<u>PARTS</u>	<u>DESCRIPTION</u>	<u>PRICE</u>
<u>No.</u> <u>No.</u>	<u>Per Kit</u>		<u>Each</u>
<b>Miscellaneous (cont'd.)</b>			
85-1168-1	1	Power supply circuit board	1.80
134-36	2	Audio cable	.75
490-1	1	Alignment tool	.10
490-5	1	Nut starter	.10
391-34	1	Blue and white label	
597-260	1	Parts Order Form	
597-308	1	Kit Builders Guide	
390-926	1	Caution label	
		Solder (Additional 3' rolls of solder can be ordered for 15 cents each.)	
	1	Assembly Manual (See front cover for part number.)	2.00

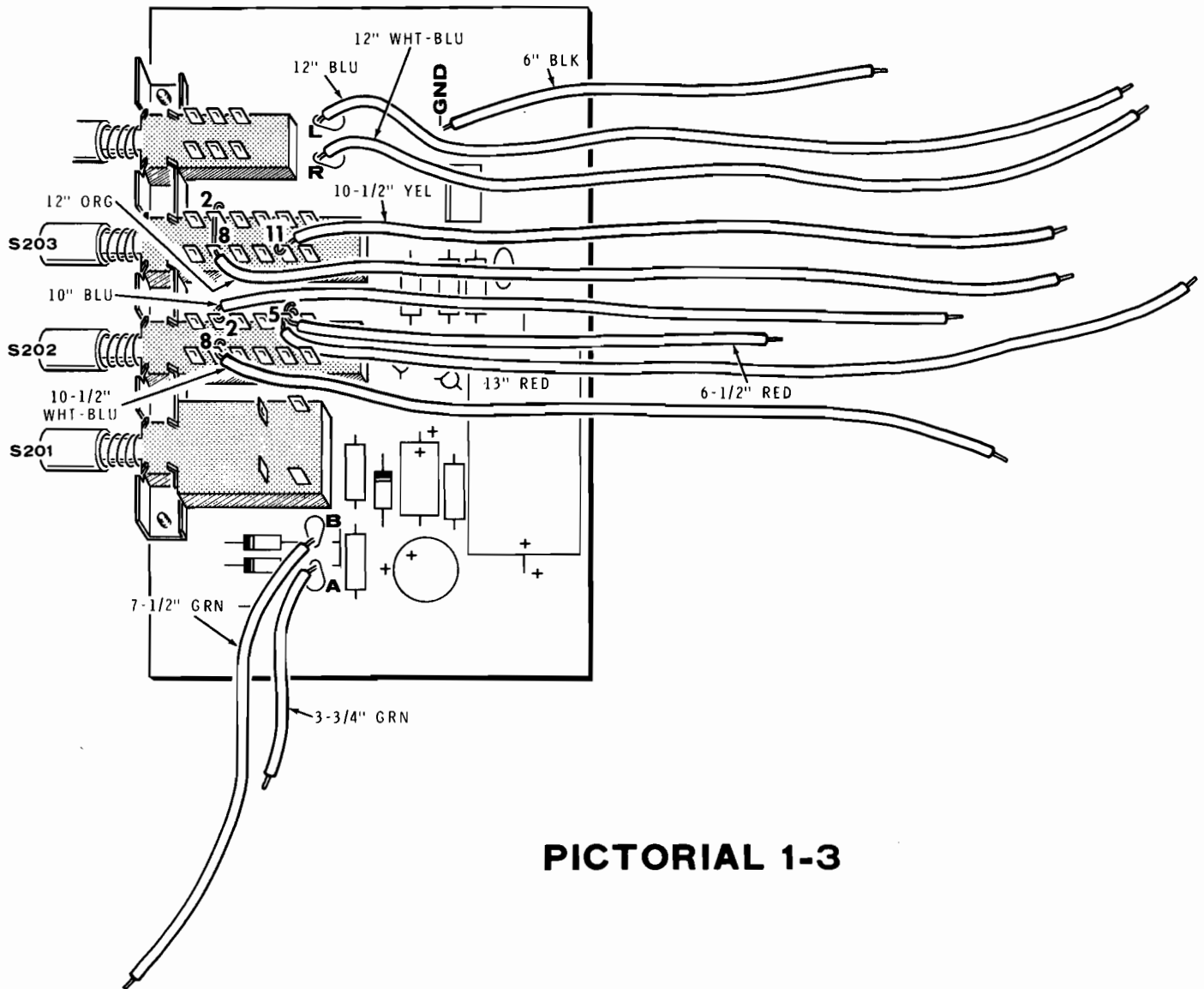



# STEP-BY-STEP ASSEMBLY

Before you start to assemble this kit, read the "Kit Builders Guide" for complete information on wiring, soldering, and step-by-step assembly.

**SAFETY WARNING:** Avoid eye injury when you clip off excess lead length from circuit boards. We suggest that you wear glasses, or at least clip the leads so the ends will not fly towards your eyes.

## CIRCUIT BOARDS

Solder a part or group of parts to the foil of the circuit board only when directed to do so. Each resistor will be called out by the resistance value (in  $\Omega$ ,  $k\Omega$ , or  $M\Omega$ ) and color code. Capacitors will be called out by the capacitance value (in pF or  $\mu F$ ) and type (disc, mica, electrolytic, tantalum, Mylar, or polystyrene).

On the circuit boards, be especially careful not to cover unused holes with solder or bridge solder across two foils. If you do make a solder bridge, hold the circuit board foil side down and with a wiping action of a clean soldering iron tip remove the solder bridge.

# CONTINUE



# START



( ) Position the power supply circuit board (#85-1168-1) component side up as shown and perform the steps in Pictorial 1-1.

( ) 2200  $\Omega$  (red-red-red).

( ) 510  $\Omega$  (green-brown-brown).

( ) 1800  $\Omega$  (brown-gray-red).

( ) 10 k $\Omega$  (brown-black-orange).

( ) 2700  $\Omega$  (red-violet-red).

( ) 1000  $\Omega$  (brown-black-red).

NOTE: DIODES MAY BE SUPPLIED IN ANY OF THE FOLLOWING SHAPES. ALWAYS POSITION THE BANDED END AS SHOWN ON THE CIRCUIT BOARD.

( ) 1N4002 silicon diode (#57-65) at D201.

( ) 1N4002 silicon diode (#57-65) at D202.

( ) Zener diode (#56-67) at D203.

FOR GOOD SOLDERED CONNECTIONS, YOU MUST KEEP THE SOLDERING IRON TIP CLEAN... WIPE IT OFTEN WITH A DAMP SPONGE OR CLOTH.

( ) Solder the leads to the foil and cut off the excess lead lengths.

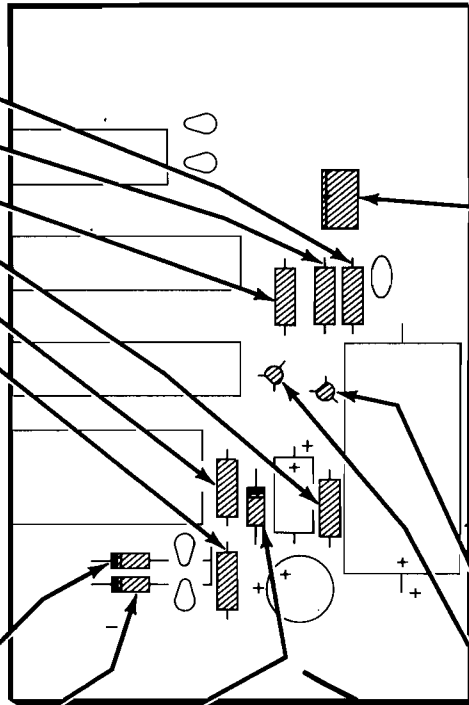

PICTORIAL 1-1

NOTE: Install the transistor in the next step as follows:

1. Position the transistor over its outline and bend the center lead to line up with the holes in the circuit board.
2. Insert the leads of the transistor into the proper holes indicated by E, C, and B.
3. Solder the leads to the foil and cut off the excess lead lengths.

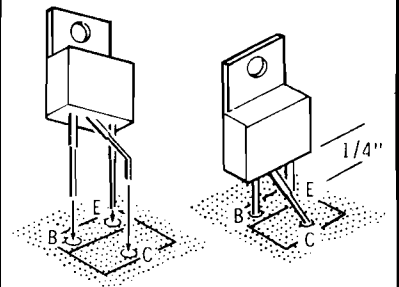

( ) 2N5294 transistor (#417-175) at Q203.

NOTE: Install the following transistors in the manner shown. First line up the flat of the transistor with the outline of the flat on the circuit board. Insert the transistor leads into their correct holes indicated by E, C, and B. Solder each lead to the foil and cut off the excess lead length.

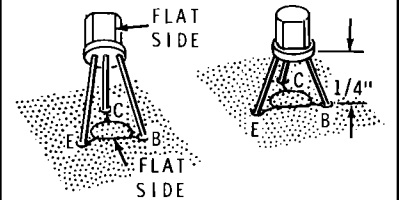

( ) 2N3393 transistor (#417-118) at Q201.

( ) 2N3393 transistor (#417-118) at Q202.

**START**

NOTE: Check the leads of each disc, mica or Mylar capacitor as you install it. Remove the coating from each capacitor as shown. This coating could cause a bad solder connection.

REMOVE COATING EVEN WITH BOTTOM OF CAPACITOR BODY

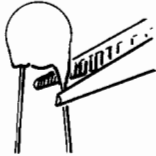

( ) .1  $\mu$ F disc.

NOTE: When installing electrolytic capacitors, always match the positive (+) mark on the capacitor with the positive (+) mark on the circuit board.

VERTICAL ELECTROLYTIC      TUBULAR ELECTROLYTIC



( ) 2  $\mu$ F electrolytic.

( ) 100  $\mu$ F electrolytic.

( ) 500  $\mu$ F electrolytic.

( ) Solder the leads to the foil and cut off the excess lead lengths.

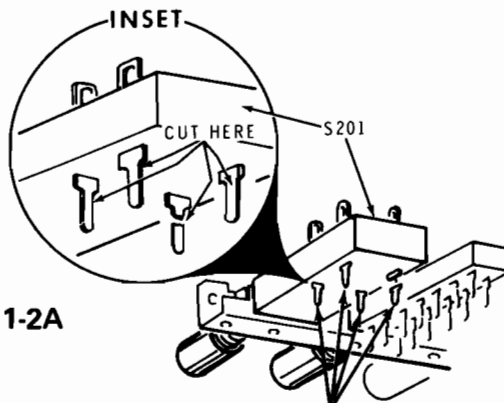
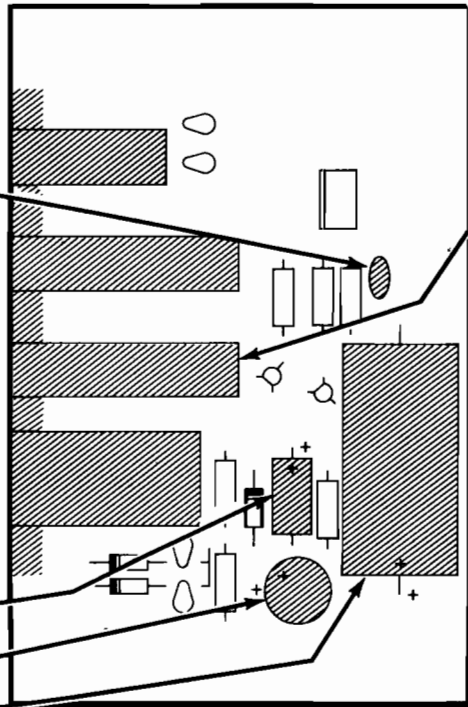

Detail 1-2A

CUT OFF ONLY THESE FOUR LUGS ON THIS SWITCH.

**CONTINUE**

( ) Refer to Detail 1-2A at the bottom of this page, and cut the four lugs (without holes) from switch S201. NOTE: Cut each lug as shown in the inset drawing. Do not cut off any other switch lugs.

( ) Install the switch assembly on the circuit board by carefully inserting all of the switch lugs in their mounting holes. Then push the assembly onto the circuit board, alternately pressing each switch.



CIRCUIT BOARD

Make sure the switch mounting bar is against the circuit board along its entire length.

Also make sure the assembly is parallel with the circuit board. Then turn the assembly over and solder two lugs on each end of the switch assembly. Check the switch assembly to make sure it is straight. If the assembly is straight, solder the other switch lugs.

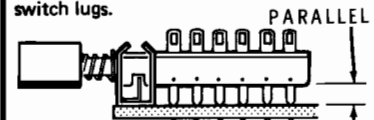

CIRCUIT BOARD

**CIRCUIT BOARD CHECKOUT**

Carefully inspect the circuit board for the following conditions.

- ( ) Unsoldered connections.
- ( ) "Cold" solder connections.
- ( ) Solder bridges between foil patterns.
- ( ) Protruding leads which could touch together.
- ( ) Transistors for the proper type and installation.
- ( ) Electrolytic capacitors for the correct position of the positive (+) end.
- ( ) Diodes for the correct position of the banded end.
- ( ) Switch lugs shorted together by protruding leads or too much solder.

This completes the assembly of the circuit board. Set it aside until it is called for in a step.

PICTORIAL 1-2

**FINISH**

Refer to Pictorial 1-3 (fold-out from Page 8) for the following steps.

NOTE: When wiring this kit, you will be instructed to prepare lengths of wire ahead of time, as in the following step. Always use hookup wire unless stranded wire is called for. To prepare a wire, cut the indicated color wire to the specified length and remove 1/4" of insulation from each end. When stranded wire is called for, melt a small amount of solder on the bare wire ends to hold the small wire strands together.

( ) Prepare the following lengths of wire. The wires are listed in the order in which they will be used.

- |                |                    |
|----------------|--------------------|
| 6" black       | 13" red            |
| 12" blue       | 10" blue           |
| 12" white-blue | 10-1/2" white-blue |
| 10-1/2" yellow | 7-1/2" green       |
| 12" orange     | 3-3/4" green       |
| 6-1/2" red     |                    |

NOTE: In the following steps, (NS) means not to solder because other wires will be added later. "S-" with a number, such as (S-3), means to solder the connection. The number following the "S" tells how many wires are at the connection.

In the following steps, connect one end of each wire to the indicated hole or switch lug of the power supply circuit board. The free end of each wire will be connected later.

- ( ) 6" black to the indicated GND hole (S-1).
- ( ) 12" blue to hole L (S-1).
- ( ) 12" white-blue to hole R (S-1).
- ( ) 10-1/2" yellow to lug 11 of switch S203 (S-1).
- ( ) Remove an extra 1/4" of insulation from one end of the 12" orange wire. Pass this end of the wire through lug 8 to lug 2 of switch S203. Solder both lugs.
- ( ) 6-1/2" red to lug 5 of switch S202 (NS).
- ( ) 13" red to lug 5 of switch S202 (S-2).
- ( ) 10" blue to lug 2 of switch S202 (S-1).
- ( ) 10-1/2" white-blue to lug 8 of switch S202 (S-1).
- ( ) 7-1/2" green to hole B (S-1).
- ( ) 3-3/4" green to hole A (S-1).

This completes the assembly of the power supply circuit board. Be sure all connections are soldered, that all excess lead lengths are cut off, and that no solder bridges exist between foils.

Set the circuit board aside until called for later.

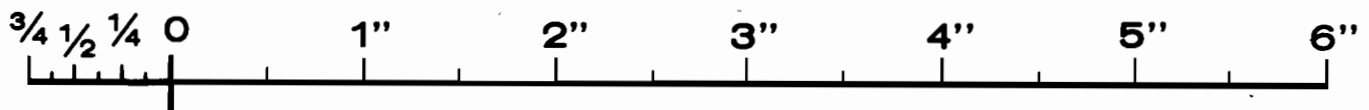

The steps performed in this Pictorial are in this area of the circuit board.

IDENTIFICATION DRAWING

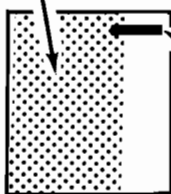

PART NUMBER

**START**



**CONTINUE**



NOTE: Due to the large size of the tuner circuit board, only part of the board will be shown at a time. An identification drawing at the top of the page will show the area of the circuit board to be assembled.

( ) Position the tuner circuit board (#85-1164-1) component side up as shown.

( ) 1500 Ω (brown-green-red).

( ) 68 kΩ (blue-gray-orange).

( ) 330 Ω (orange-orange-brown).

( ) 8200 Ω (gray-red-red).

( ) 47 kΩ (yellow-violet-orange).

FOR GOOD SOLDERED CONNECTIONS, YOU MUST KEEP THE SOLDERING IRON TIP CLEAN... WIPE IT OFTEN WITH A DAMP SPONGE OR CLOTH.

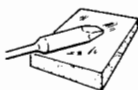

( ) Solder the leads to the foil and cut off the excess lead lengths.

( ) 100 Ω (brown-black-brown).

( ) 1500 Ω (brown-green-red).

( ) 680 kΩ (blue-gray-yellow).

( ) 330 Ω (orange-orange-brown).

( ) 68 kΩ (blue-gray-orange).

( ) 6800 Ω (blue-gray-red).

( ) Solder the leads to the foil and cut off the excess lead lengths.

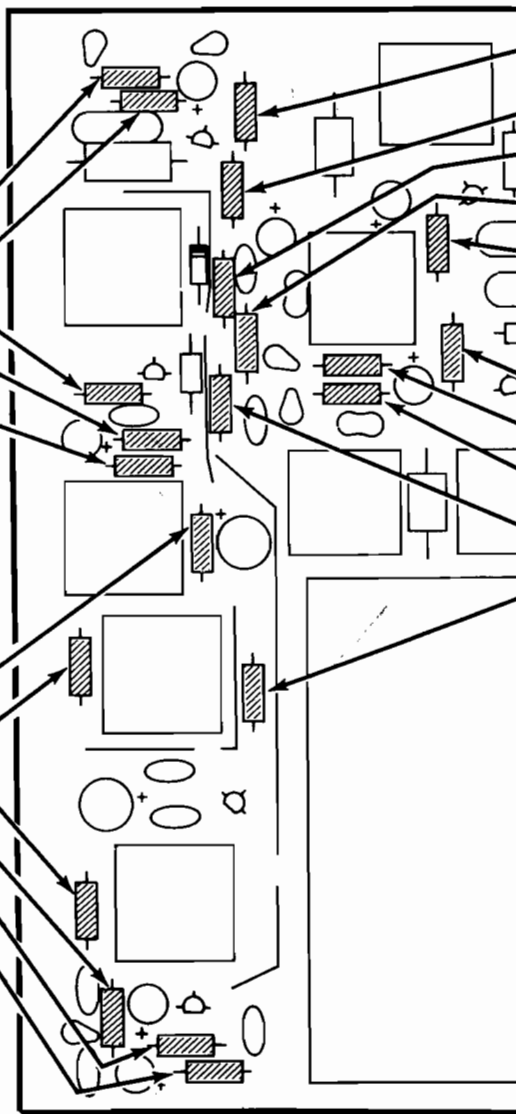

( ) 15 kΩ (brown-green-orange).

( ) 4700 Ω (yellow-violet-red).

( ) 1000 Ω (brown-black-red).

( ) 1000 Ω (brown-black-red).

( ) 1200 Ω (brown-red-red).

( ) Solder the leads to the foil and cut off the excess lead lengths.

( ) 1200 Ω (brown-red-red).

( ) 6800 Ω (blue-gray-red).

( ) 6800 Ω (blue-gray-red).

( ) 4700 Ω (yellow-violet-red).

( ) 1500 Ω (brown-green-red).

( ) Solder the leads to the foil and cut off the excess lead lengths.

PICTORIAL 2-1



The steps performed in this Pictorial are in this area of the circuit board.

IDENTIFICATION DRAWING

PART NUMBER

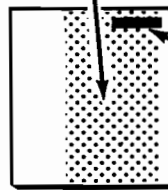

**START**

**CONTINUE**

- ( ) 15 kΩ (brown-green-orange).
- ( ) 150 kΩ (brown-green-yellow).
- ( ) 390 kΩ (orange-white-yellow).
- ( ) 2700 Ω (red-violet-red).
- ( ) 8200 Ω (gray-red-red).
- ( ) 8200 Ω (gray-red-red).
- ( ) Solder the leads to the foil and cut off the excess lead lengths.
- ( ) 2700 Ω (red-violet-red).
- ( ) 1000 Ω (brown-black-red).
- ( ) 390 kΩ (orange-white-yellow).
- ( ) 150 kΩ (brown-green-yellow).
- ( ) 390 kΩ (orange-white-yellow).
- ( ) 150 kΩ (brown-green-yellow).
- ( ) 180 kΩ (brown-gray-yellow).
- ( ) Solder the leads to the foil and cut off the excess lead lengths.

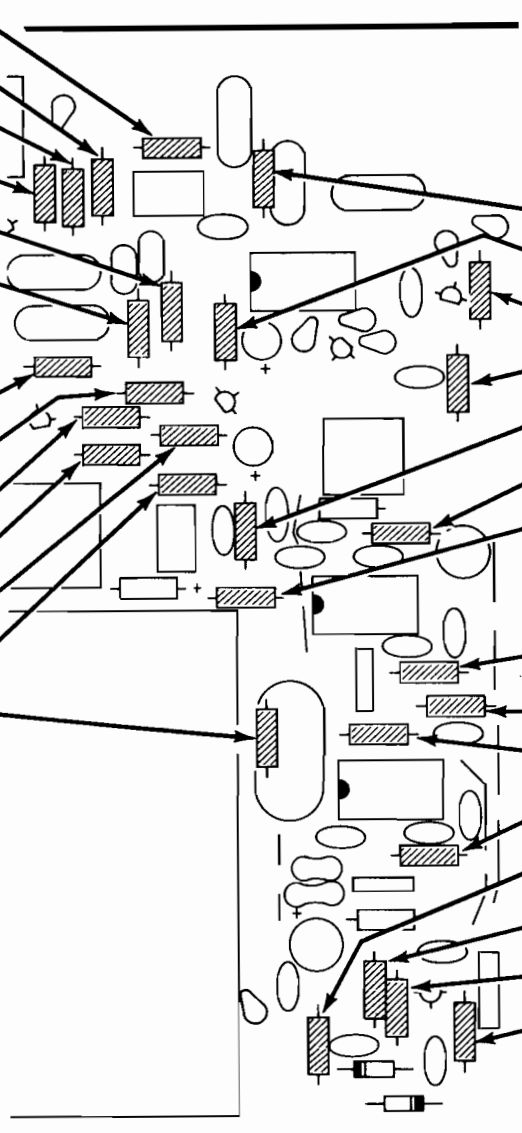

- ( ) 1000 Ω (brown-black-red).
- ( ) 2200 Ω (red-red-red).
- ( ) 100 kΩ (brown-black-yellow).
- ( ) 560 kΩ (green-blue-yellow).
- ( ) 10 kΩ (brown-black-orange).
- ( ) 100 Ω (brown-black-brown).
- ( ) 680 kΩ (blue-gray-yellow).
- ( ) Solder the leads to the foil and cut off the excess lead lengths.
- ( ) 330 Ω (orange-orange-brown).
- ( ) 100 Ω (brown-black-brown).
- ( ) 330 Ω (orange-orange-brown).
- ( ) 330 Ω (orange-orange-brown).
- ( ) 10 kΩ (brown-black-orange).
- ( ) 5600 Ω (green-blue-red).
- ( ) 47 kΩ (yellow-violet-orange).
- ( ) 200 Ω (red-black-brown).
- ( ) Solder the leads to the foil and cut off the excess lead lengths.

**PICTORIAL 2-2**

The steps performed in this Pictorial are in this area of the circuit board.

PART NUMBER

IDENTIFICATION DRAWING

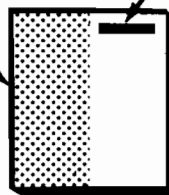

CONTINUE



START



( ) 1N191 diode (brown-white-brown) at D3. Position the banded end as shown.

NOTE: When a jumper is called for in a step, cut the green wire to the specified length and remove 1/4" of insulation from each end.

( ) 3" jumper.

( ) 4-1/4" jumper.

( ) 2-3/8" jumper.

( ) Solder the leads to the foil and cut off the excess lead lengths.

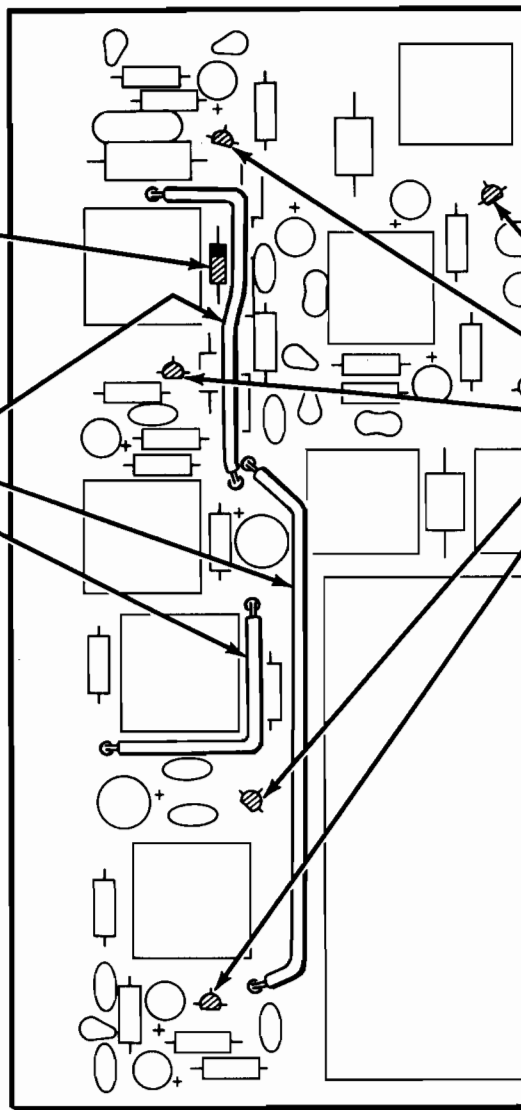

NOTE: Install the following transistors in the manner shown. First line up the flat of the transistor with the outline of the flat on the circuit board. Insert the transistor leads into their correct holes indicated by E, C, and B. Solder each lead to the foil and cut off the excess lead length.

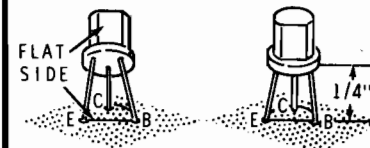

( ) 2N5232A transistor (#417-91) at Q8.

( ) 2N3393 transistor (#417-118) at Q13.

( ) E844 transistor (#417-85) at Q12.

( ) E843 transistor (#417-84) at Q11.

( ) L842 transistor (#417-83) at Q10.

PICTORIAL 2-3

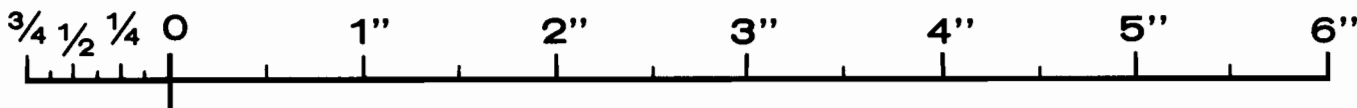

The steps performed in this Pictorial are performed in this area of the circuit board.

IDENTIFICATION DRAWING

PART NUMBER

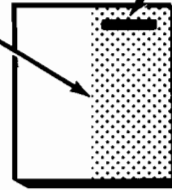

**START**



**NOTE:** Install the following transistors in the manner shown. First line up the flat of the transistor with the outline of the flat on the circuit board. Insert the transistor leads into their correct holes indicated by E, C, and B. Solder each lead to the foil and cut off the excess lead length.



- ( ) 2N5232A transistor (#417-91) at Q7.
- ( ) 2N5249A transistor (#417-213) at Q3.
- ( ) X29A829 transistor (#417-201) at Q5.
- ( ) 2N3393 transistor (#417-118) at Q14.
- ( ) 2N3393 transistor (#417-118) at Q6.

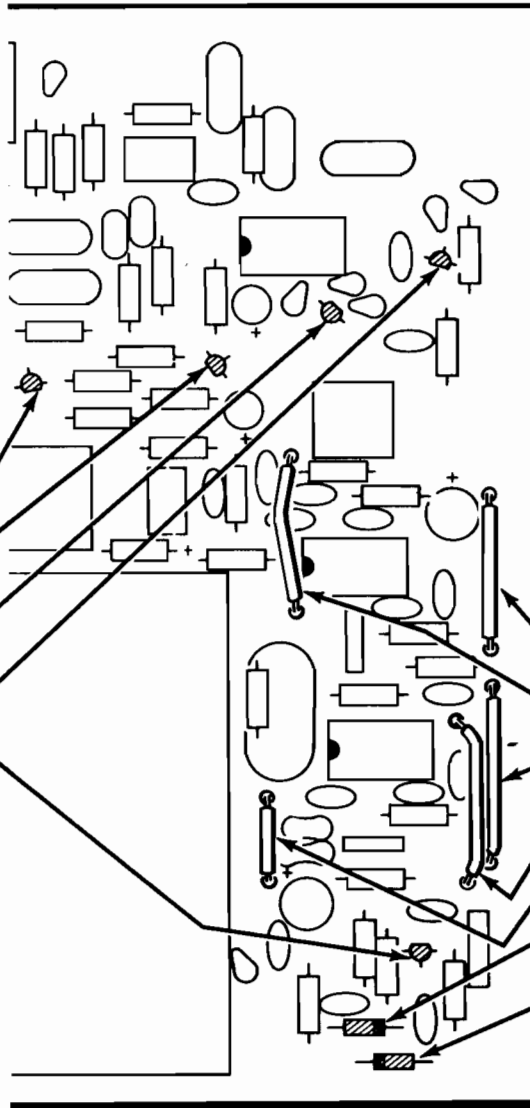

**CONTINUE**



- ( ) 1-1/2" jumper.
- ( ) 1-1/2" jumper.
- ( ) 1-1/2" jumper.
- ( ) 1-3/4" jumper.
- ( ) 1" jumper.
- ( ) 1N4149 diode (#56-56) at D2. Position the banded end as shown.
- ( ) 1N4149 diode (#56-56) at D1.
- ( ) Solder the leads to the foil and cut off the excess lead lengths.

PICTORIAL 2-4

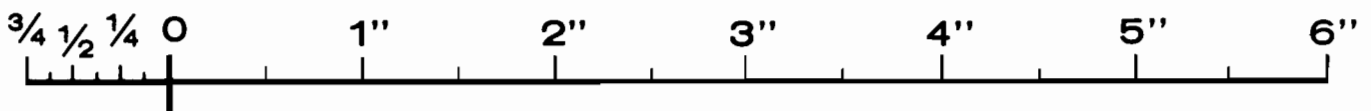

The steps performed in this Pictorial are in this area of the circuit board.

IDENTIFICATION DRAWING

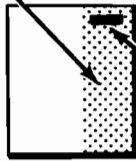

PART NUMBER

**START**



**NOTE:** Solder the pins to the foil as each part is installed.

( ) IC socket at IC3.

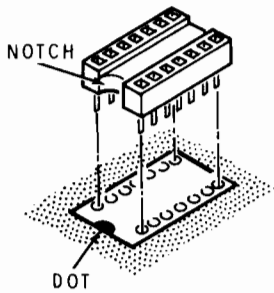

Align the notch of the socket with the dot on the outline on the circuit board. Be sure each pin of the socket is in its hole in the circuit board before soldering the pins to the foil.

( ) MC1310 IC (#442-46). Before applying pressure to the IC, align the notch or dot of the IC with the notch of the IC socket. Also be sure the IC pins are aligned with the holes in the socket.

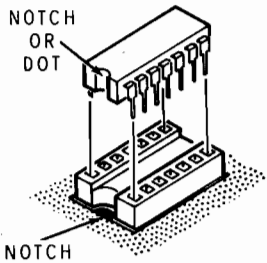

( ) 5000  $\Omega$  (5 k) control (#10-311).

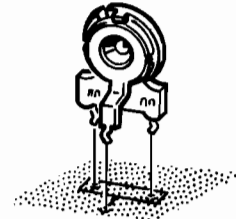

( ) 100 k $\Omega$  control (#10-941).

**NOTE:** The integrated circuits installed in the next two steps are mounted directly onto the circuit board. Align their notch or dot end with the dot on the circuit board. Also, be sure the pins are aligned with the circuit board holes before pressing the IC in place.

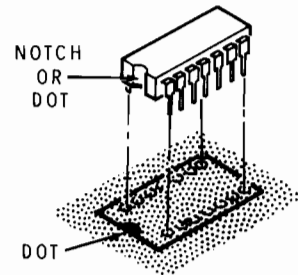

( ) MC1357 IC (#442-28) at IC2.

( ) MC1357 IC (#442-28) at IC1.

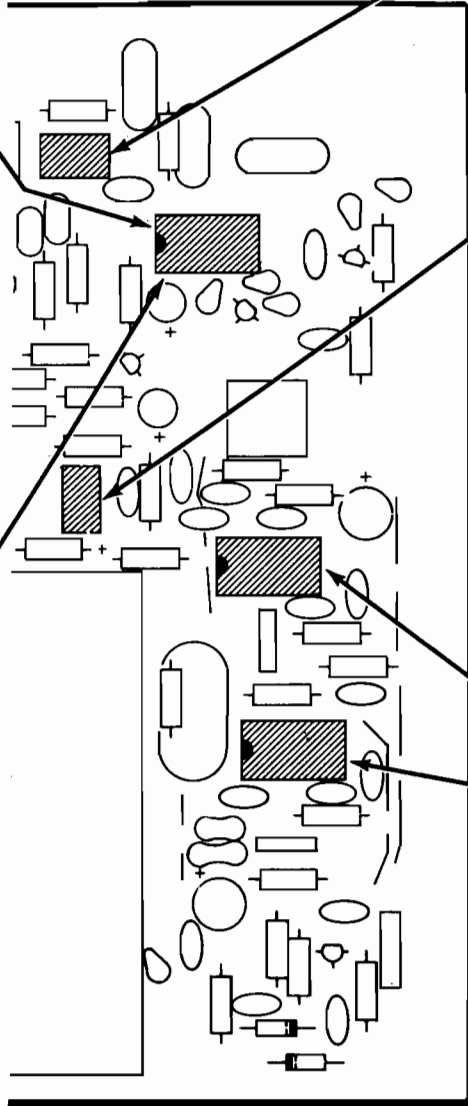

PICTORIAL 2-5

# START



NOTE: Check the leads of each disc, mica or Mylar capacitor as you install it. Remove the coating from each capacitor as shown. This coating could cause a bad solder connection.

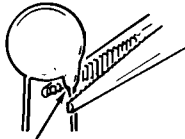

REMOVE COATING EVEN WITH BOTTOM OF CAPACITOR BODY

The steps performed in this Pictorial are in this area of the circuit board.

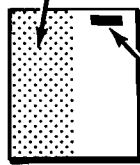

PART NUMBER

IDENTIFICATION DRAWING

# CONTINUE



( ) .1  $\mu$ F Mylar.

NOTE: When installing electrolytic capacitors, always match the positive (+) mark on the capacitor with the positive (+) mark on the circuit board.

VERTICAL ELECTROLYTIC      TUBULAR ELECTROLYTIC

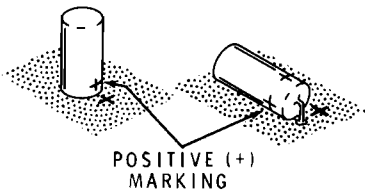

POSITIVE (+) MARKING

( ) 10  $\mu$ F electrolytic.

( ) .05  $\mu$ F disc.

( ) .56 pF phenolic (green-blue-gray).

( ) .05  $\mu$ F disc.

( ) .05  $\mu$ F disc.

( ) 100  $\mu$ F electrolytic.

( ) 10  $\mu$ F electrolytic.

( ) .05  $\mu$ F disc.

( ) 10  $\mu$ F electrolytic.

( ) .05  $\mu$ F disc.

( ) Solder the lead to the foil and cut off the excess lead lengths.

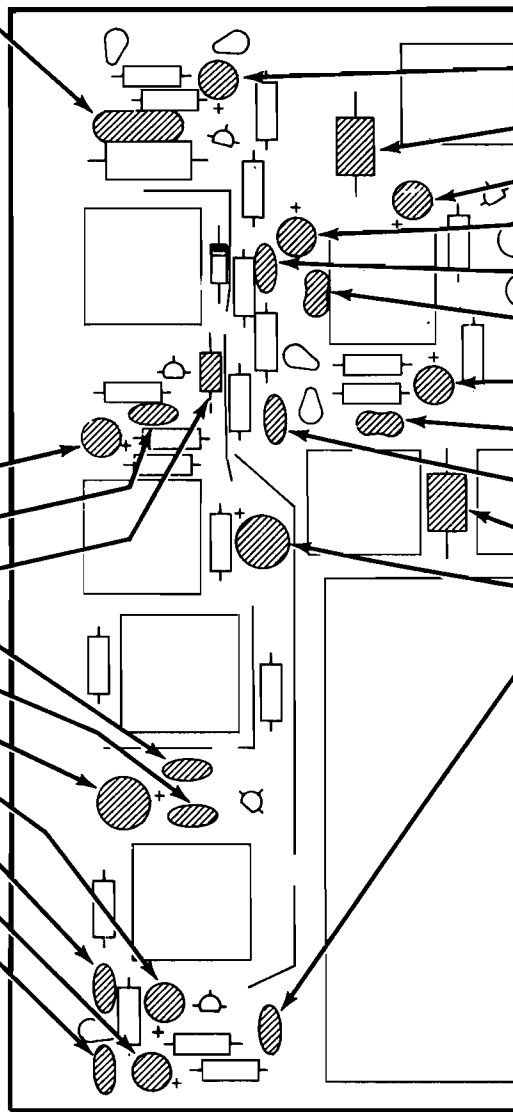

( ) 10  $\mu$ F electrolytic.

( ) 3300 pF polystyrene.

( ) 10  $\mu$ F electrolytic.

( ) 10  $\mu$ F electrolytic.

( ) .02  $\mu$ F disc.

( ) 300 pF mica.

( ) 10  $\mu$ F electrolytic.

( ) 300 pF mica.

( ) .02  $\mu$ F disc.

( ) 3300 pF polystyrene.

( ) 100  $\mu$ F electrolytic.

( ) .1  $\mu$ F disc.

( ) Solder the leads to the foil and cut off the excess lead lengths.

PICTORIAL 2-6



The steps performed in this Pictorial are in this area of the circuit board.

IDENTIFICATION DRAWING

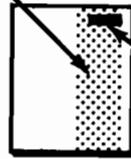

PART NUMBER

**START**



**CONTINUE**



- ( ) .22  $\mu$ F Mylar.
- ( ) 510 pF disc.
- ( ) .0091  $\mu$ F Mylar.
- ( ) .0091  $\mu$ F Mylar.
- ( ) .22  $\mu$ F Mylar.
- ( ) .22  $\mu$ F Mylar.
- ( ) 10  $\mu$ F electrolytic.
- ( ) 10  $\mu$ F electrolytic.
- ( ) .1  $\mu$ F disc.
- ( ) Solder the leads to the foil and cut off the excess lead lengths.
- ( ) .001  $\mu$ F disc. NOTE: This is not the .001  $\mu$ F 1.4 kV disc.
- ( ) 1  $\mu$ F tantalum. Position the + end as shown.
- ( ) .27  $\mu$ F Mylar.
- ( ) .05  $\mu$ F disc.
- ( ) 620 pF mica.
- ( ) 150 pF mica.
- ( ) 100  $\mu$ F electrolytic.
- ( ) .1  $\mu$ F disc.
- ( ) Solder the leads to the foil and cut off the excess lead lengths.

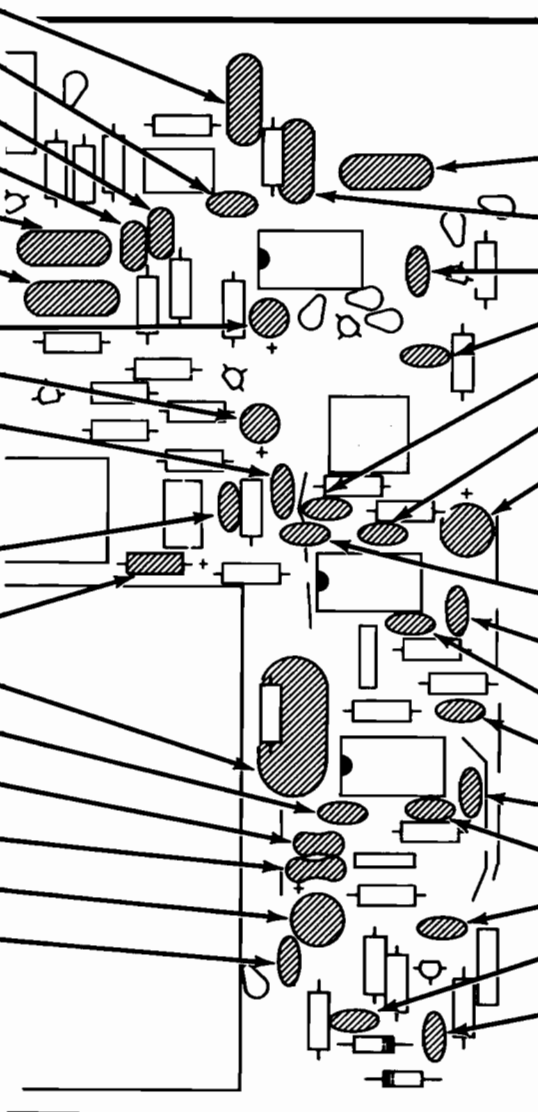

- ( ) .22  $\mu$ F Mylar.
- ( ) .47  $\mu$ F Mylar.
- ( ) .05  $\mu$ F disc.
- ( ) 470  $\mu$ F disc.
- ( ) .05  $\mu$ F disc.
- ( ) 10 pF disc.
- ( ) 100  $\mu$ F electrolytic.
- ( ) Solder the leads to the foil and cut off the excess lead lengths.
- ( ) 100 pF disc.
- ( ) .1  $\mu$ F disc.
- ( ) .1  $\mu$ F disc.
- ( ) .05  $\mu$ F disc.
- ( ) .1  $\mu$ F disc.
- ( ) .1  $\mu$ F disc.
- ( ) 33 pF disc.
- ( ) .05  $\mu$ F disc.
- ( ) .05  $\mu$ F disc.
- ( ) Solder the leads to the foil and cut off the excess lead lengths.

PICTORIAL 2-7

The steps performed in this Pictorial are in this area of the circuit board.

**START**

**NOTE:** Solder the pins or leads to the foil as each part is installed. Cut off any excess lead lengths.

( ) Choke (#45-47) at 2  $\mu$ H. Bend the leads towards the slot.

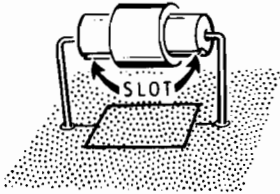

( ) 455 kHz IF transformer (#52-90) at T6.

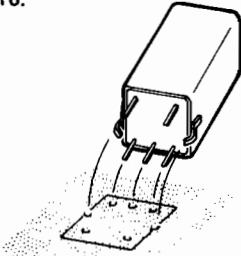

( ) 455 kHz IF transformer (#52-89) at T5.

( ) Oscillator transformer (#52-157) at T4.

( ) RF transformer (#52-158) at T3.

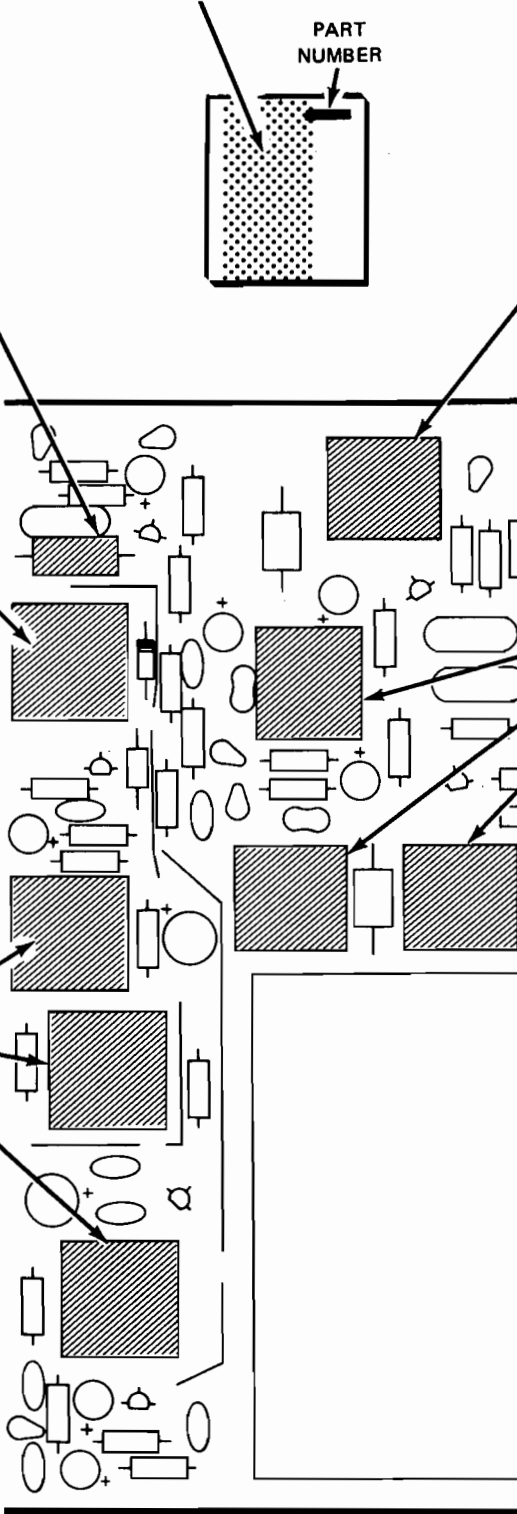

**CONTINUE**

( ) Coil #40-956 at L4.

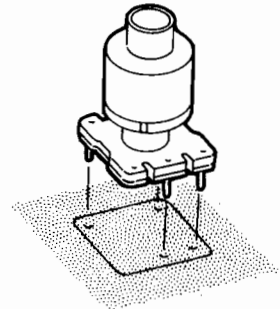

( ) Coil #40-957 at L5.

( ) Coil #40-957 at L7.

( ) Coil #40-956 at L6.

PICTORIAL 2-8

The steps performed in this Pictorial are in this area of the circuit board.

IDENTIFICATION DRAWING

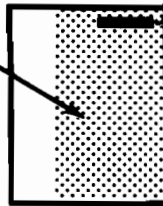

PART NUMBER

**START**



Solder the pins or leads to the foil as each part is installed. Cut off any excess lead lengths.

( ) 10.7 MHz IF transformer (#52-154) at L3.

( ) Ceramic filter (#404-530-1) at F2.  
NOTE: The filter may be installed either way on the circuit board.

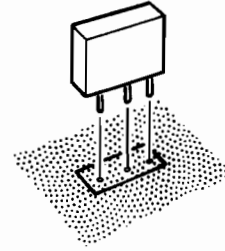

( ) Ceramic filter (#404-530-1) at F1.

( ) Choke (#45-57) at L1.

( ) Toroid coil (#40-961) at L2.



( ) Tuner assembly (#110-67). If the tuner plates are not fully closed, turn the shaft clockwise and close them all the way so they do not get bent. Fit the pins and tabs of the tuner assembly into the proper holes in the circuit board. Press down firmly and then solder the pins and the tabs to the foil.

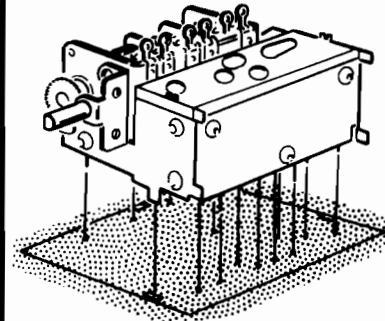

This completes the assembly of this circuit board. Be sure all connections are soldered and that no solder bridges exist between foils. Then set it aside until it is called for later.

NOTE: The remaining 3300  $\Omega$  (orange-orange-red) and 2.2 M $\Omega$  (red-red-green) resistors will be used later.

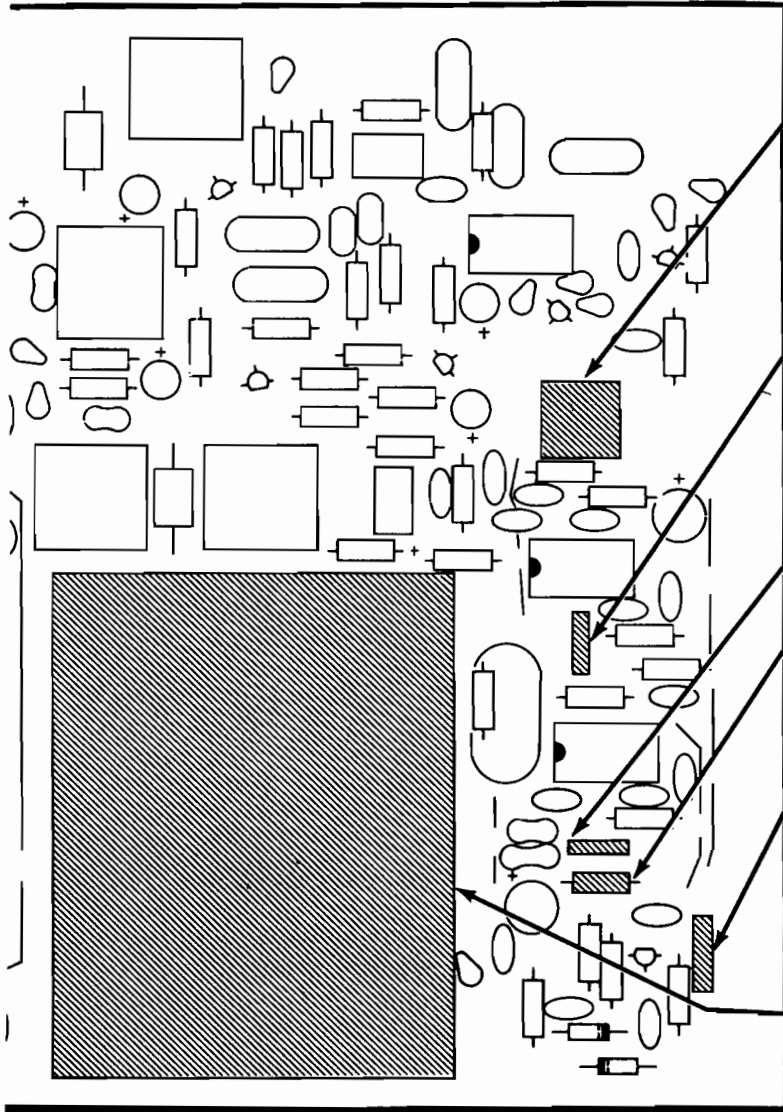

PICTORIAL 2-9

## CHASSIS

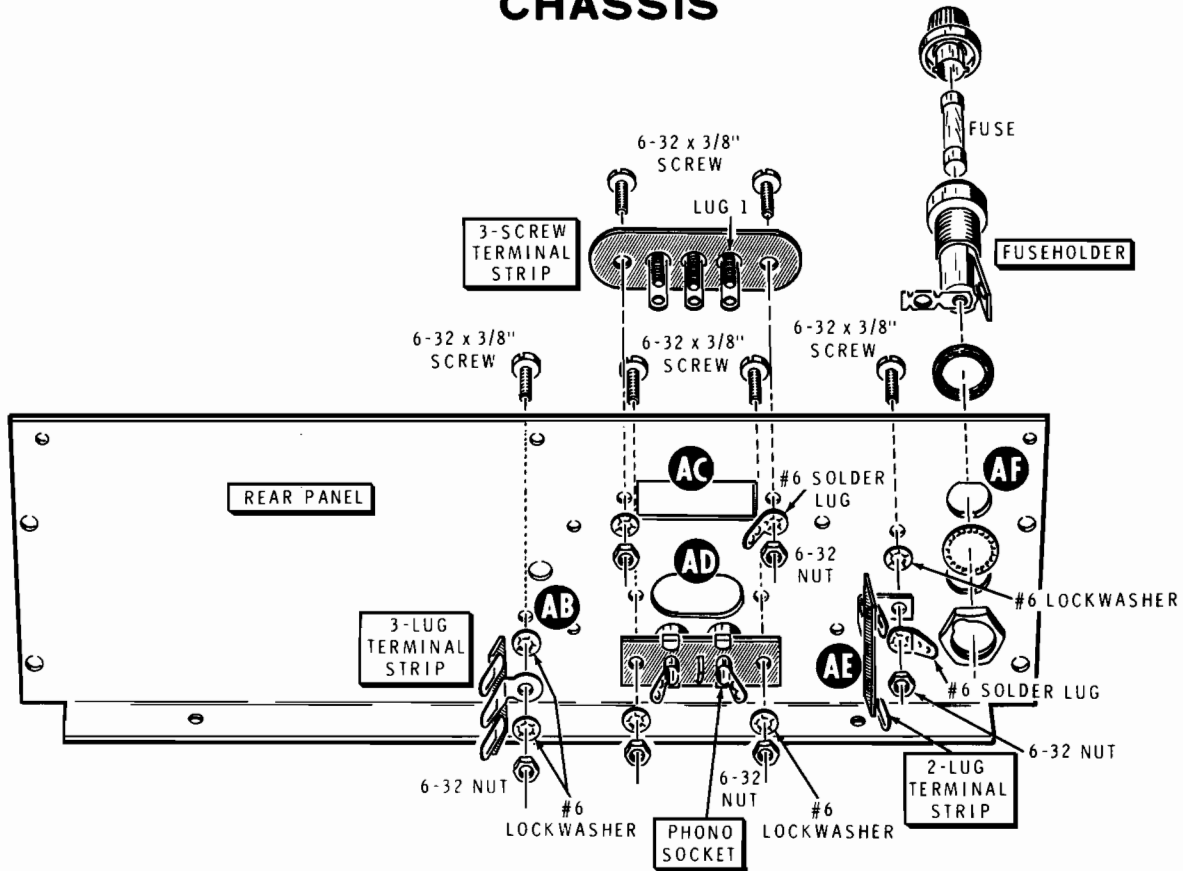

**PICTORIAL 3-1**

Refer to Pictorial 3-1 for the following steps.

- ( ) Mount a 3-lug terminal strip at hole AB. Use a 6-32 x 3/8" screw, two #6 lockwashers, and a 6-32 nut.
- ( ) Mount a 3-screw terminal strip at AC on the rear panel. Use two 6-32 x 3/8" screws, a #6 lockwasher, a #6 solder lug and two 6-32 nuts. Position the solder lug so that it touches lug 1 of the terminal strip.
- ( ) Mount the dual phono socket at AD on the rear panel. Use two 6-32 x 3/8" screws, two #6 lockwashers, and two 6-32 nuts.
- ( ) Mount a 2-lug terminal strip at AE with a 6-32 x 3/8" screw, a #6 lockwasher, a #6 solder lug, and a 6-32 nut. Position the solder lug as shown in the Pictorial.
- ( ) Mount the fuseholder in hole AF of the rear panel. Use the hardware furnished with the fuseholder.

- ( ) Install the 3/16-ampere slow-blow fuse in the fuseholder.

Refer to Pictorial 3-2 for the following steps.

- ( ) Mount the left end to the rear panel with two #6 x 1/4" black sheet metal screws.
- ( ) Mount the chassis to the rear panel with two #6 x 1/4" black sheet metal screws.
- ( ) Mount the center support bracket to the rear panel with a #6 x 1/4" black sheet metal screw in the upper mounting hole. Use the antenna mounting bracket and a #6 x 1/4" black sheet metal screw in the lower mounting hole. **CAUTION:** Be sure the dimples in the antenna mounting bracket are seated in the matching holes in the rear panel.
- ( ) Mount the front panel to the left end, the center support bracket, and the chassis with seven #6 x 1/4" black sheet metal screws.





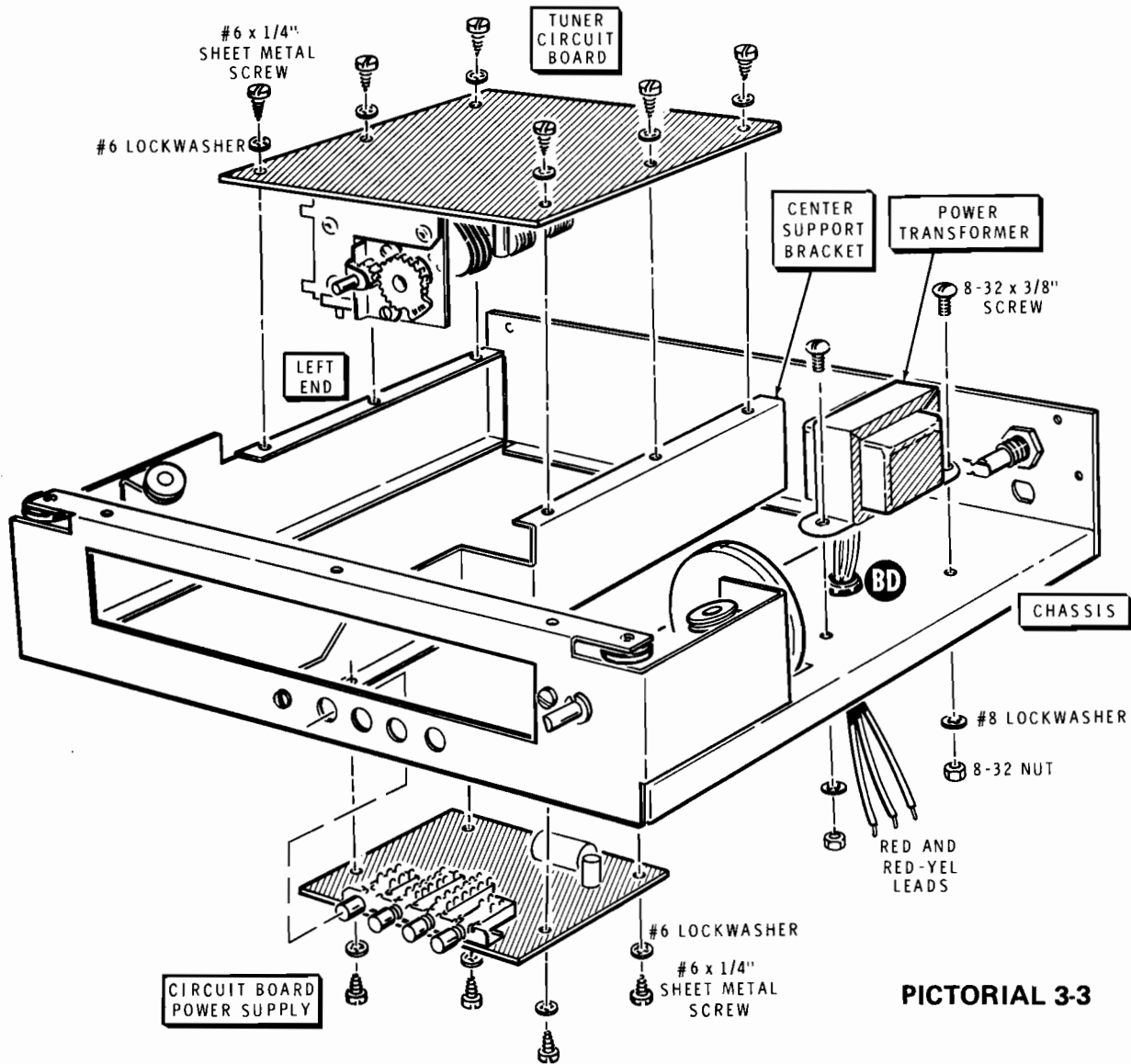

**PICTORIAL 3-3**

Refer to Pictorial 3-3 for the following steps.

- ( ) Refer to Detail 3-3A and cut the indicated leads of the power transformer to the specified lengths. Then remove 1/2" of insulation from each of these leads.
- ( ) Position the power transformer on the chassis at BD. Route the two red and the red-yellow transformer leads through grommet BD as shown.
- ( ) Mount the power transformer to the chassis with two 8-32 x 3/8" screws, two #8 lockwashers, and two 8-32 nuts.
- ( ) Mount the tuner circuit board to the left end and center support bracket with six #6 x 1/4" sheet metal screws and #6 lockwashers. Position the circuit board as shown.

- ( ) Mount the power supply circuit board on the center support bracket and chassis with four #6 x 1/4" sheet metal screws and #6 lockwashers. Position the pushbuttons through their holes in the front panel. Be sure not to pinch any wires between the circuit board and chassis assembly.

Refer to Pictorial 3-4 (fold-out from Page 27) for the following steps.

- ( ) Pass the two red and the red-yellow power transformer leads through grommet BC in the chassis.

Connect the free ends of these leads to the power supply circuit board as follows:

- ( ) Either red lead to either hole AC (S-1).

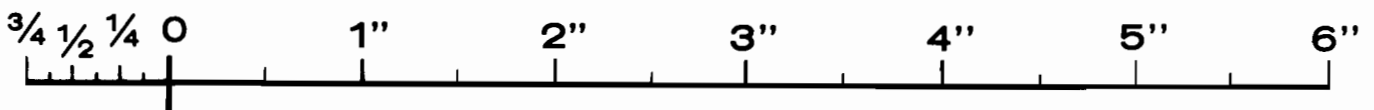

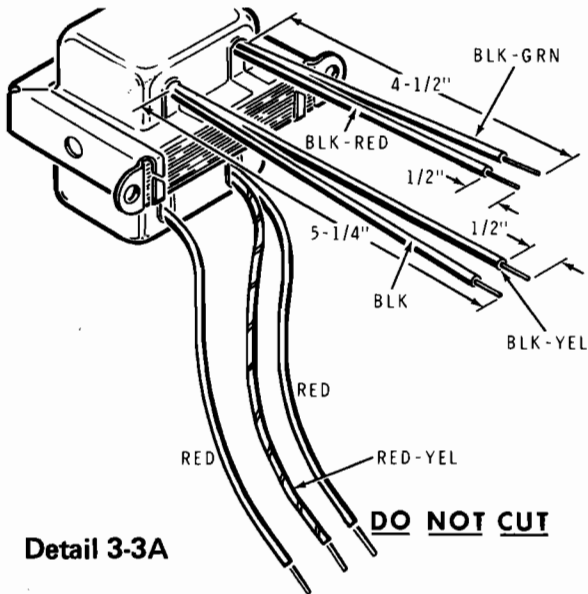

Detail 3-3A

- ( ) Other red lead to the other hole AC (S-1).
- ( ) Yellow-red lead to hole GND (S-1).
- ( ) Remove 1/4" of insulation from each end of two 12" black stranded wires. Melt a small amount of solder on the bare ends of each wire to hold the small strands together. Then slightly flatten one end of each wire.
- ( ) From the bottom of the chassis, pass the flattened end of one of the black stranded wires through grommet BC. Then form a small hook in the flattened end of the wire.
- ( ) Insert the hook through lug 6 of switch S201. Then crimp the hook around the lug with a pair of pliers and make a mechanically secure connection.
- ( ) In a like manner pass the flattened end of the other black stranded wire through grommet BC and connect it to lug 5 of switch S201.
- ( ) Now solder lugs 5 and 6 of switch S201.
- ( ) Position the free ends of the eleven wires coming from the power supply circuit board toward the rear panel.
- ( ) Refer to inset drawing #1 of Pictorial 3-4 and prepare the paper insulator (#75-156) as shown. Then remove the paper backing from the insulator.
- ( ) Refer to inset drawing #2 and place the insulator over switch S201 as shown. Press the bent-down section of the insulator against the side of switch S201 and the top section down against the top of the chassis.

- ( ) Loosely twist together the free ends of the black stranded wires. Then pass them up through grommet BA in the chassis.

NOTE: In each of the following steps, be sure you make a mechanically secure connection before soldering. To do this, pass the wire or lead through the lug; then crimp it around the lug with a pair of pliers.

- ( ) Connect either black stranded wire to lug 2 of terminal strip AE (NS).
- ( ) Connect the other black stranded wire to lug 2 of fuseholder AF (S-1).
- ( ) Connect a 2.2 megohm resistor (red-red-green) from lug 1 of fuseholder AF (NS) to the solder lug at terminal strip AE (S-1).
- ( ) Connect a .001  $\mu$ F 1.4 kV disc capacitor between lugs 1 (NS) and 2 (NS) of terminal strip AE. Keep the capacitor leads as short as possible.
- ( ) Bend this capacitor toward the rear panel as shown.
- ( ) Locate the line cord and separate the leads for a length of 1-1/2". Then, melt a small amount of solder on the bare wire ends.
- ( ) Pass the end of the line cord through hole AG in the rear panel.
- ( ) Connect the ribbed lead of the line cord (see inset drawing #3) to lug 1 of terminal strip AE (NS).
- ( ) Connect the smooth lead of the line cord to lug 1 of fuseholder AF (S-2).
- ( ) Refer to Detail 3-4A and install the line cord strain relief in hole AG of the rear panel.

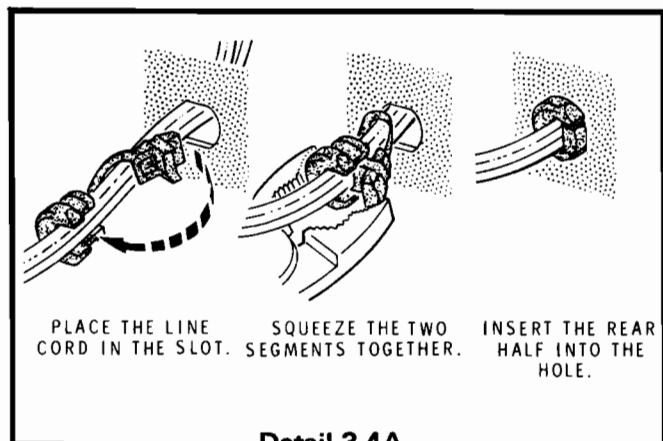

Detail 3-4A

### ALTERNATE LINE VOLTAGE WIRING

Two sets of line voltage wiring instructions are given, one for 120 VAC line voltage and the other for 240 VAC line voltage. In the U.S.A., 120 VAC is most often used, while in other countries 240 VAC is more common. USE ONLY THE INSTRUCTIONS THAT AGREE WITH THE LINE VOLTAGE IN YOUR AREA.

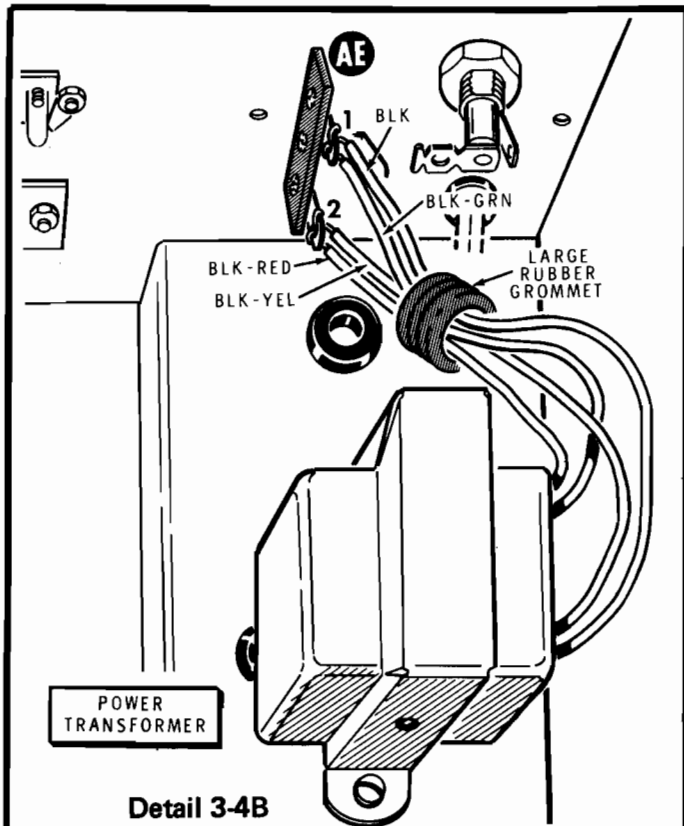

Detail 3-4B

#### 120 VAC Wiring

Refer to Detail 3-4B for the following steps.

- ( ) Insert all four power transformer leads through a large rubber grommet (#73-3) as shown.

Connect the power transformer leads as follows:

- ( ) Black to lug 1 of terminal strip AE (NS).
- ( ) Black-green to lug 1 of terminal strip AE (S-4).
- ( ) Black-red to lug 2 of terminal strip AE (NS).
- ( ) Black-yellow to lug 2 of terminal strip AE (S-4).

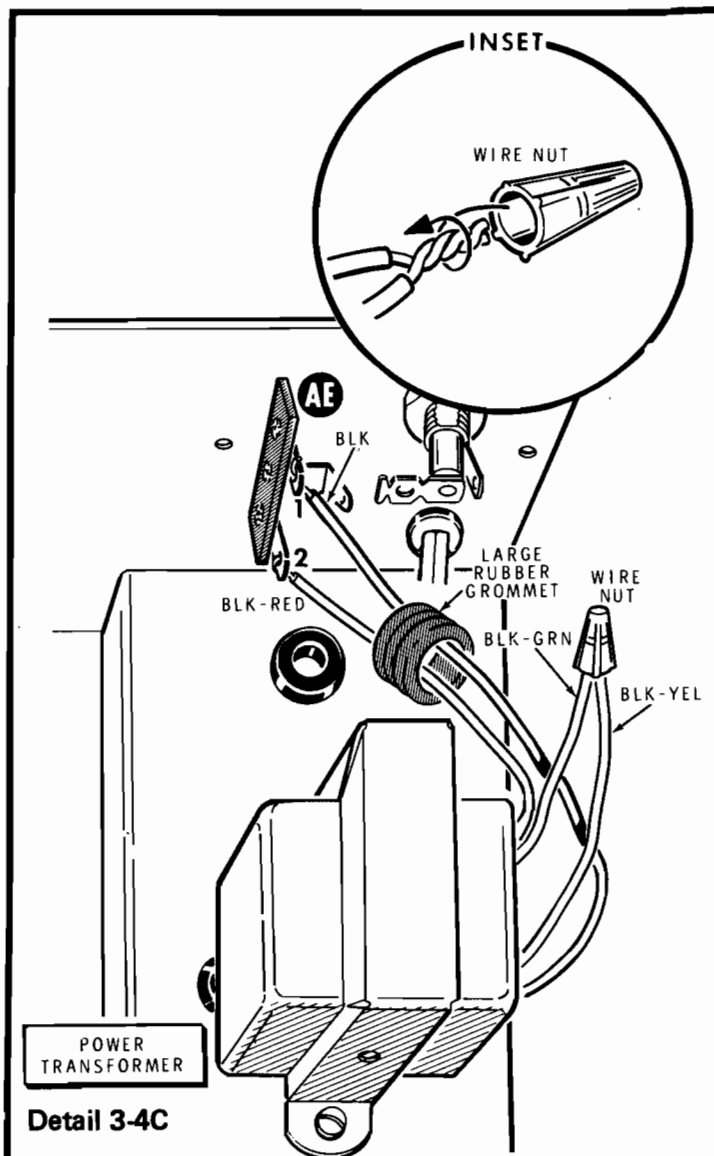

Detail 3-4C

#### 240 VAC Wiring

Refer to Detail 3-4C for the following steps.

- ( ) Insert the black and the black-red transformer leads through a large rubber grommet (#73-3) as shown.

Connect the power transformer leads as follows:

- ( ) Black to lug 1 of terminal strip AE (S-3).
- ( ) Black-red to lug 2 of terminal strip AE (S-3).
- ( ) Position the ends of the black-green and black-yellow leads even with each other. Then twist the wire nut tightly onto the ends of these leads in a clockwise direction.

## SHIELD AND LABEL INSTALLATION

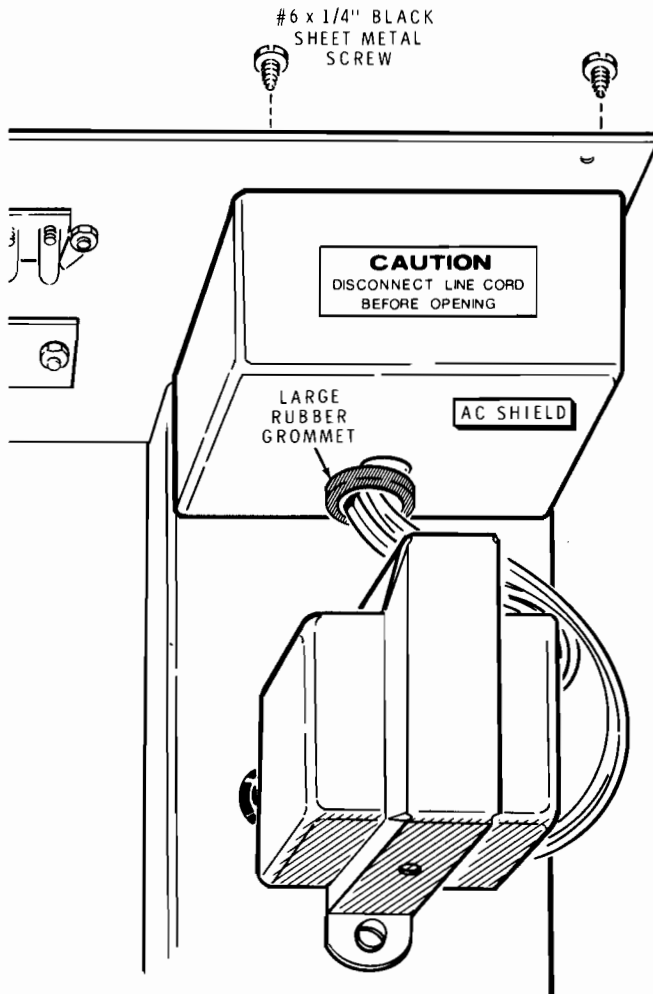

Detail 3-4D

NOTE: If the Tuner is wired for 240 VAC operation, remove the 3/16-ampere slow-blow fuse from the fuseholder and replace it with a 1/8-ampere slow-blow 3AG fuse (not supplied).

Refer to Detail 3-4D for the following steps.

- ( ) Slide the large rubber grommet that is around the power transformer leads into the slot in the AC shield. Then place the shield on the chassis over the fuseholder and terminal strip. Be sure the grommet is seated in the slot.
- ( ) Secure the AC shield to the rear panel with two #6 x 1/4" black sheet metal screws.
- ( ) Remove the backing paper from the caution label. Then press the label on the top of the AC shield as shown in the Detail.

NOTE: The blue and white label, to be installed in the next step, shows the Model Number and Production Series Number of your kit. Refer to these numbers in any communications with the Heath Company. This assures you that you will receive the most complete and up-to-date information in return.

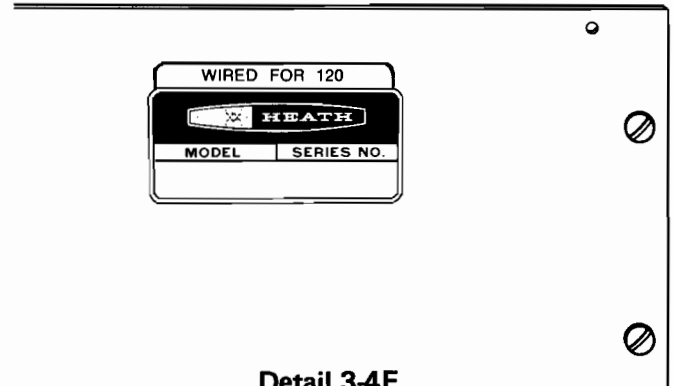

Detail 3-4E

- ( ) Carefully peel the backing paper from the blue and white label. Then refer to Detail 3-4E and press the label in place in the outlined area on the rear of the Tuner. If your Tuner is wired for 120 VAC, position the label so it covers the WIRED FOR 240 wording. If the Tuner is wired for 240 VAC, position the label so it covers the WIRED FOR 120 wording.

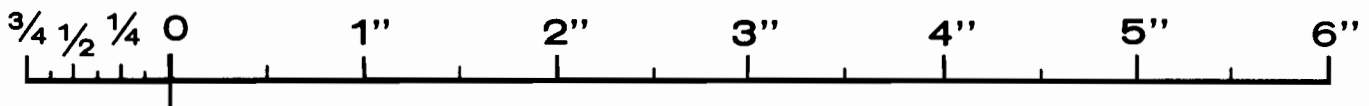

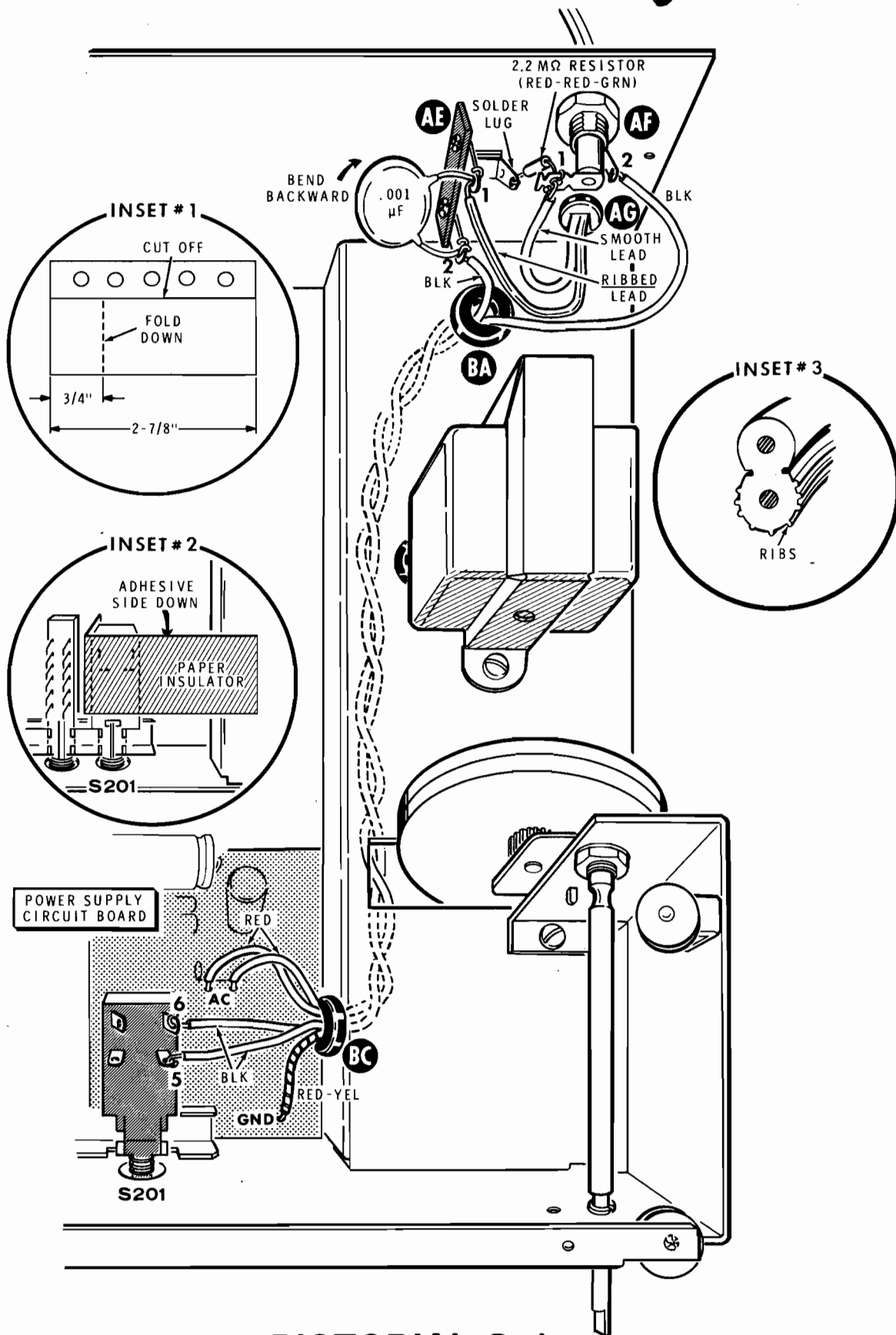

PICTORIAL 3-4

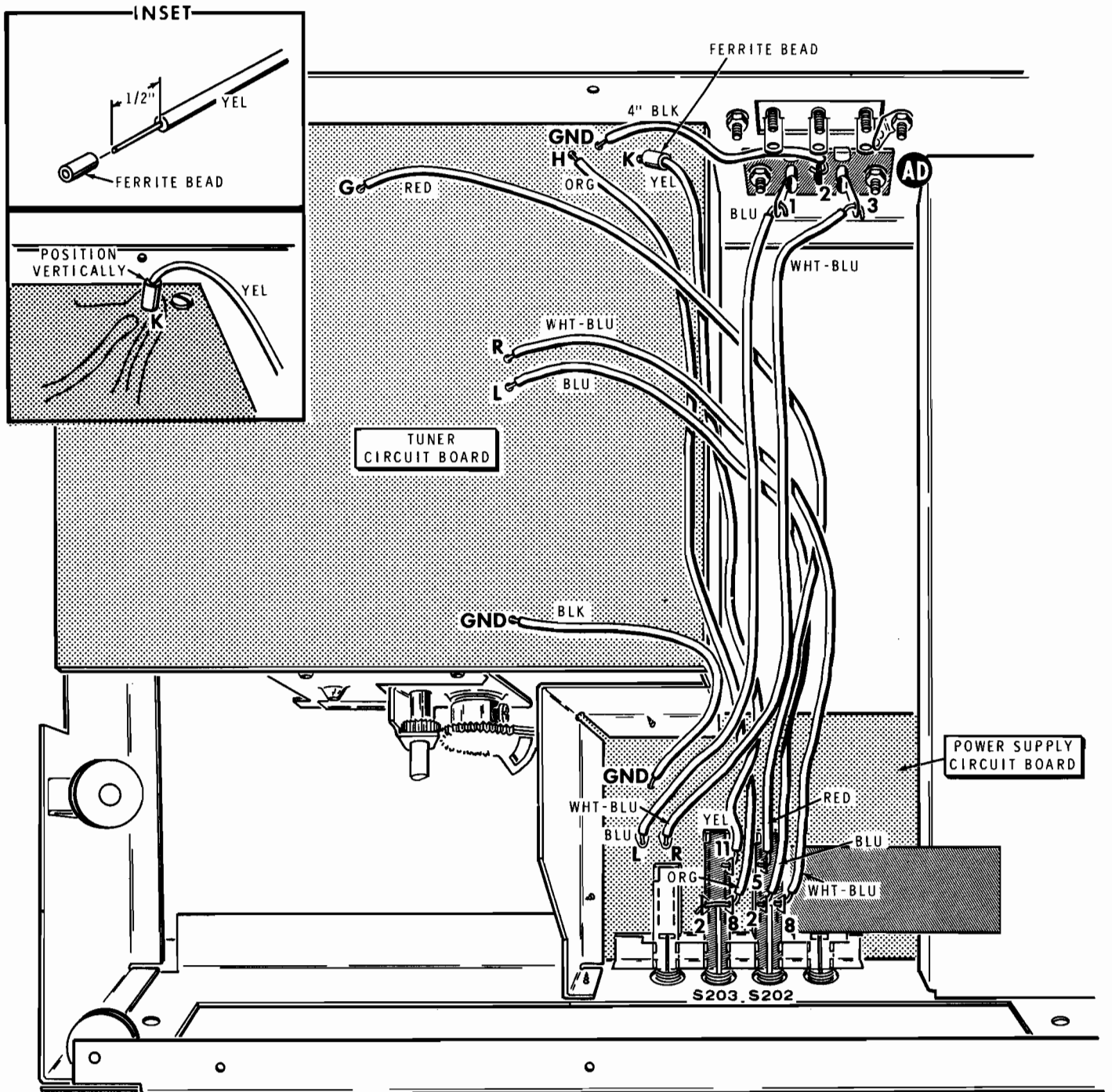

**PICTORIAL 3-5**

### CIRCUIT BOARD WIRING

Refer to Pictorial 3-5 (fold-out from this page) for the following steps.

**NOTE:** When you solder a wire to the foil side of a circuit board, as in the next step, position the wire so the insulation is 1/8" above the circuit board. This will insure a good solder connection to the wire and foil.

- ( ) Prepare a 4" length of black wire.
- ( ) Connect this wire from lug 2 (both lugs) of phono socket AD (S-1) to hole GND in the tuner circuit board (S-1).
- ( ) Locate the yellow wire coming from lug 11 of switch S203 on the power supply circuit board. Then remove an additional 1/4" of insulation from the free end of this wire.
- ( ) Refer to the inset drawing and install a ferrite bead on the free end of the yellow wire as shown. Then connect the end with the ferrite bead to hole K on the tuner circuit board (S-1). Keep the bead pushed against the insulation; then position it as shown after soldering the connection.

Connect the free ends of the wires coming from the power supply circuit board to the tuner circuit board as follows:

- ( ) Orange wire from from lug 8 of switch S203 to hole H (S-1).
- ( ) Longer red wire from lug 5 of switch S202 to hole G (S-1).
- ( ) White-blue wire from lug 8 of switch S202 to hole R (S-1).
- ( ) Blue wire from lug 2 of switch S202 to hole L (S-1).
- ( ) Black wire from hole GND to hole GND (S-1).
- ( ) Blue wire from hole L to lug 1 of phono socket AD (S-1).
- ( ) White-blue wire from hole R to lug 3 of phono socket AD (S-1).
- ( ) Position the wires along the edge of the circuit board as shown.

Set the chassis assembly aside temporarily.

Refer to Pictorial 3-6 for the following steps.

- ( ) Install a pilot lamp in each of the four pilot lamp sockets.

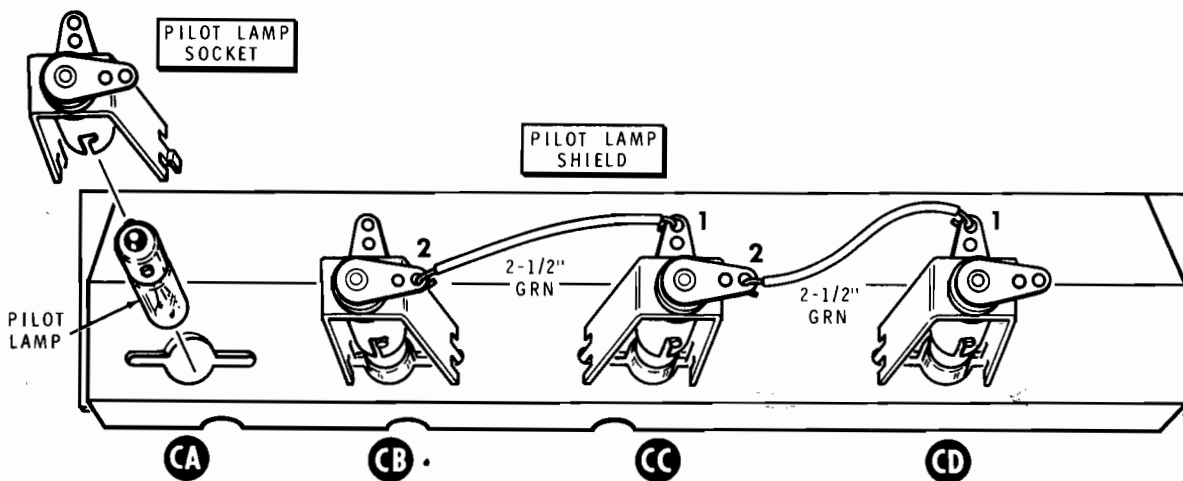

PICTORIAL 3-6

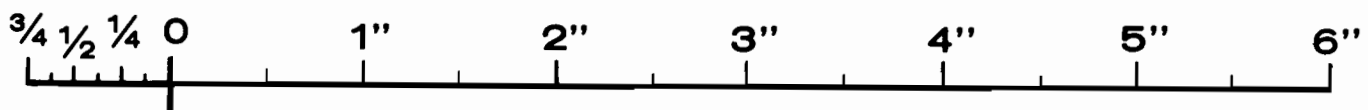



- ( ) Mount pilot lamp sockets at holes CA, CB, CC, and CD of the pilot lamp shield. Position each socket as shown.
- ( ) Prepare two 2-1/2" lengths of green wire.
- ( ) Connect a 2-1/2" green wire from lug 2 of pilot lamp socket CB (S-1) to lug 1 of pilot lamp socket CC (S-1).
- ( ) Connect a 2-1/2" green wire from lug 2 of pilot lamp socket CC (S-1) to lug 1 of pilot lamp socket CD (S-1).
- ( ) Long green wire (from hole B) to lug 1 of socket CB (S-1).
- ( ) Red wire from lug 5 of switch S202 to lug 2 of socket CA (S-1).
- ( ) Prepare a 20" length of brown wire.
- ( ) Connect the 20" brown wire from lug 1 of pilot lamp socket CA (S-1) to hole 1 in the tuner circuit board (S-1). Route this wire as shown.

Refer to Pictorial 3-7 (fold-out from this page) for the following steps.

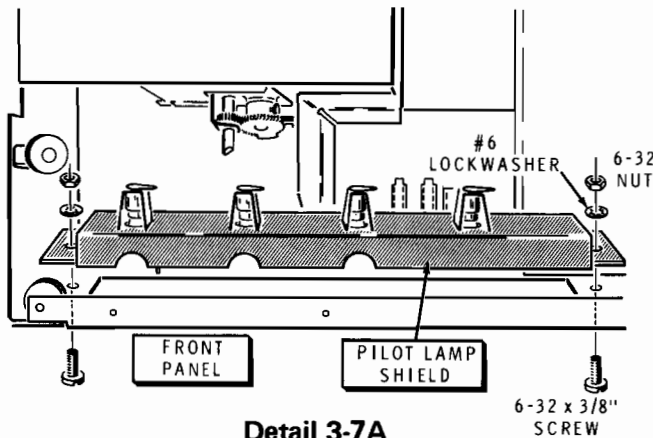

Detail 3-7A

- ( ) Refer to Detail 3-7A and mount the pilot lamp shield to the front panel with two 6-32 x 3/8" screws, two #6 lockwashers, and two 6-32 nuts.

Connect the wires from the power supply circuit board to the pilot lamp sockets as follows:

- ( ) Short green wire (from hole A) to lug 2 of socket CD (S-1).
- ( ) Long green wire (from hole B) to lug 1 of socket CB (S-1).
- ( ) Red wire from lug 5 of switch S202 to lug 2 of socket CA (S-1).
- ( ) Prepare a 20" length of brown wire.
- ( ) Connect the 20" brown wire from lug 1 of pilot lamp socket CA (S-1) to hole 1 in the tuner circuit board (S-1). Route this wire as shown.
- ( ) Refer to the inset drawing on Pictorial 3-7 and pass a cable tie around all the wires, coming from the two circuit boards at the four locations shown. Pull each cable tie tight and clip off the excess length of the tie.
- ( ) Refer to Detail 3-7B and prepare a 9-1/2" length of 300 Ω twin lead. Melt a small amount of solder on the bare ends of the wires to hold the small strands together.

NOTE: Connect both ends of the 300 Ω twin lead before you perform the solder instruction in the next step. The twin lead should be positioned as shown, should not be twisted, and should be flat.

- ( ) At either end of the length of 300 Ω twin lead, connect the short lead to lug 1 (S-1) and the long lead to lug 2 (S-1) of 3-screw terminal strip AC.
- ( ) Connect the other end of the 300 Ω twin lead to holes C in the tuner circuit board. Solder to the foil. Then cut off the excess lead lengths that protrude from the component side of the circuit board.
- ( ) Solder lug 3 of 3-screw terminal strip AC to the solder lug mounted with the terminal strip.

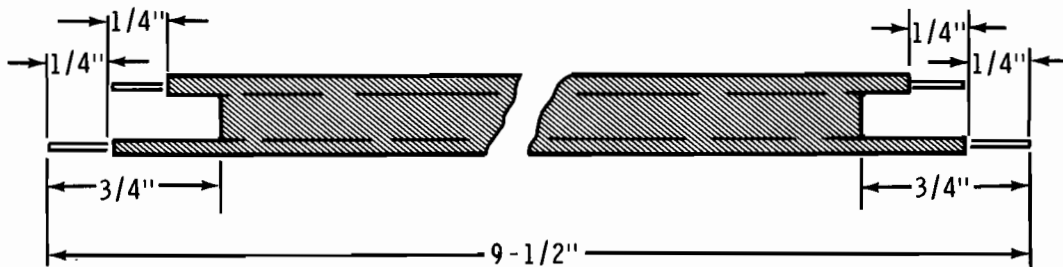

Detail 3-7B

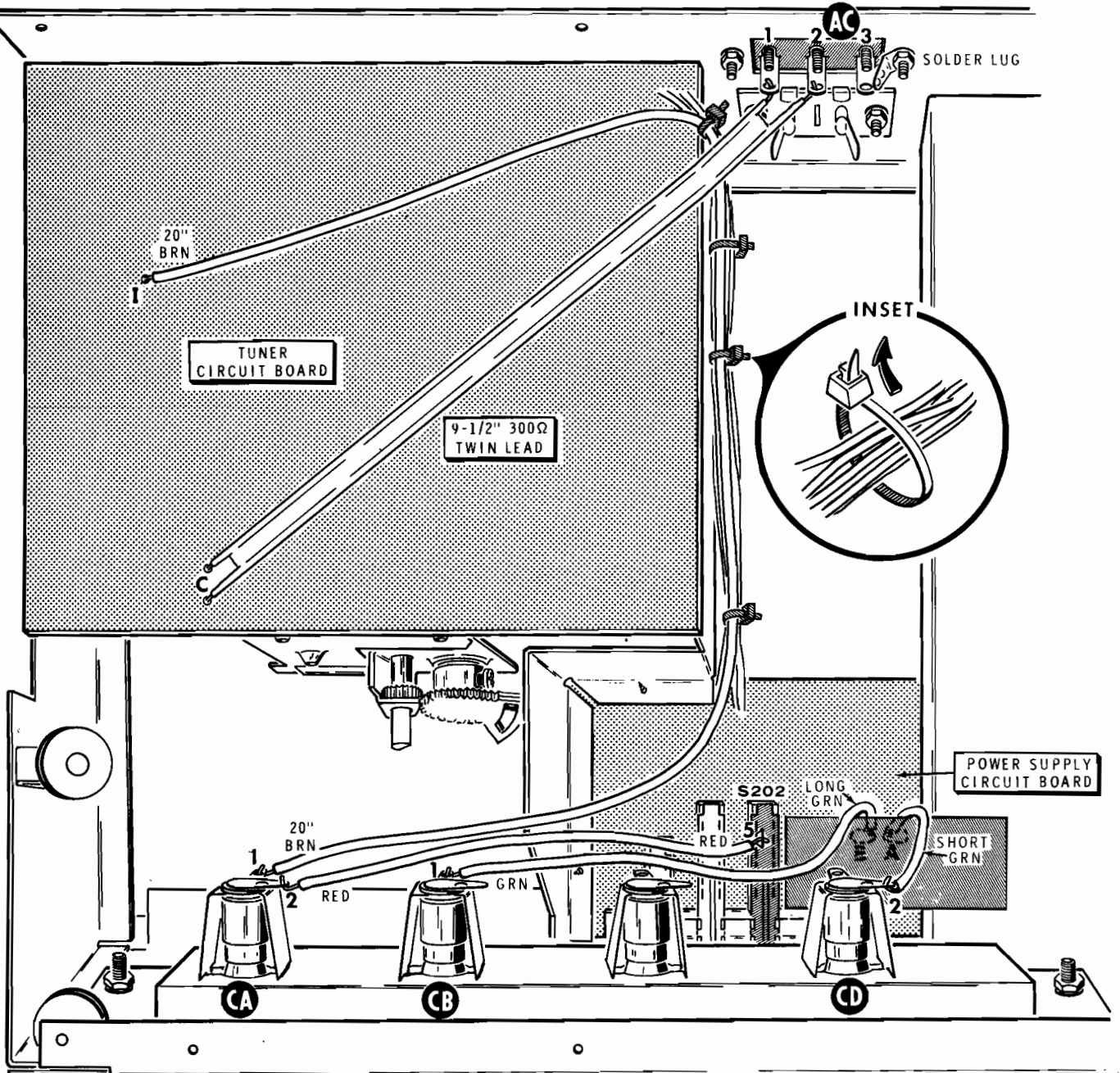

**PICTORIAL 3-7**

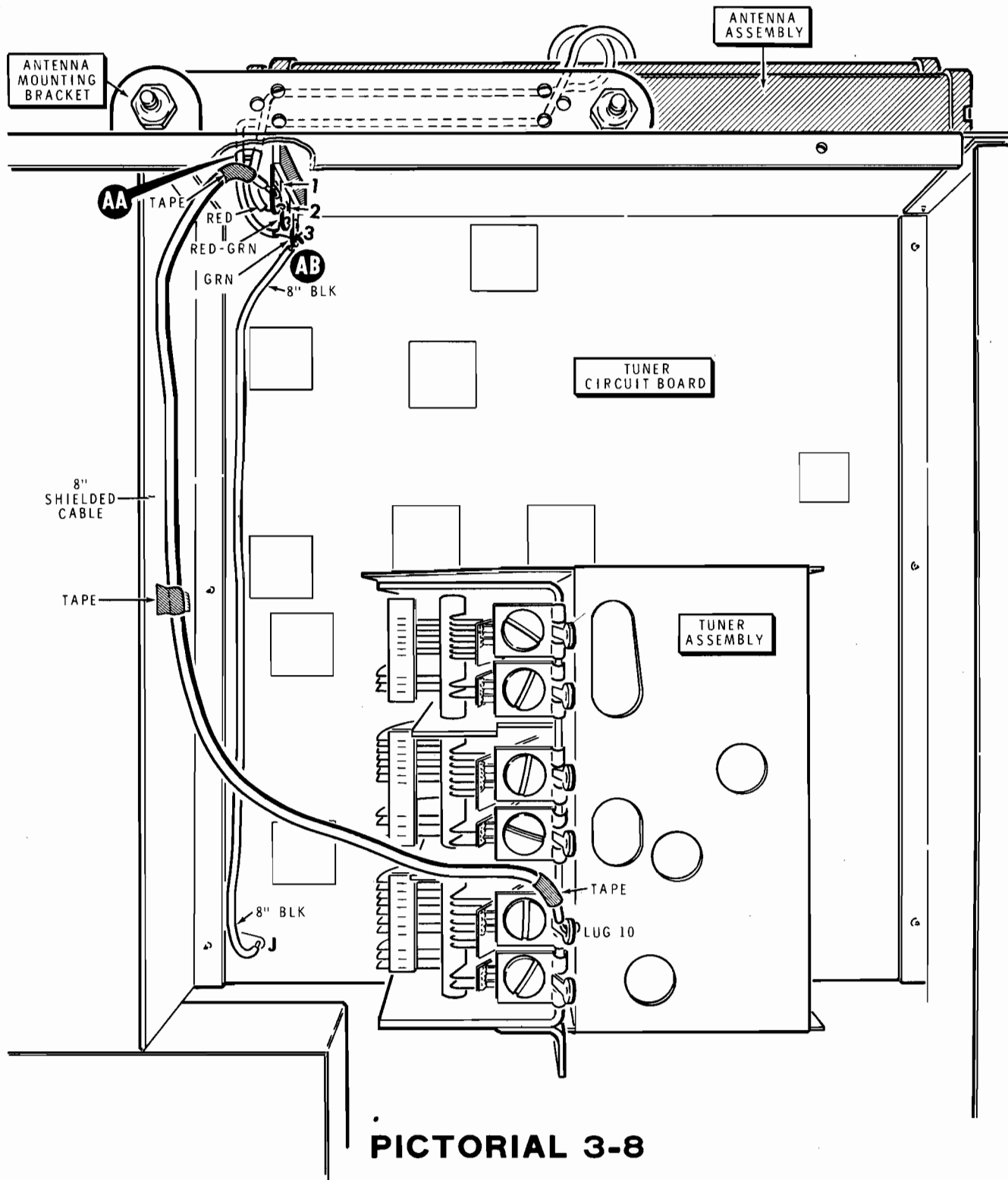

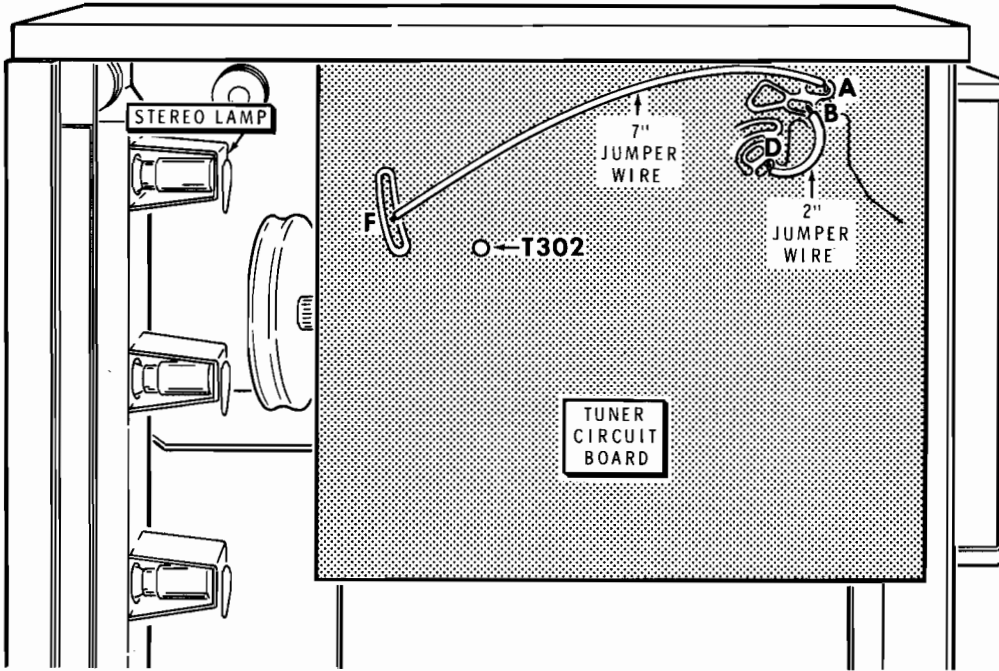
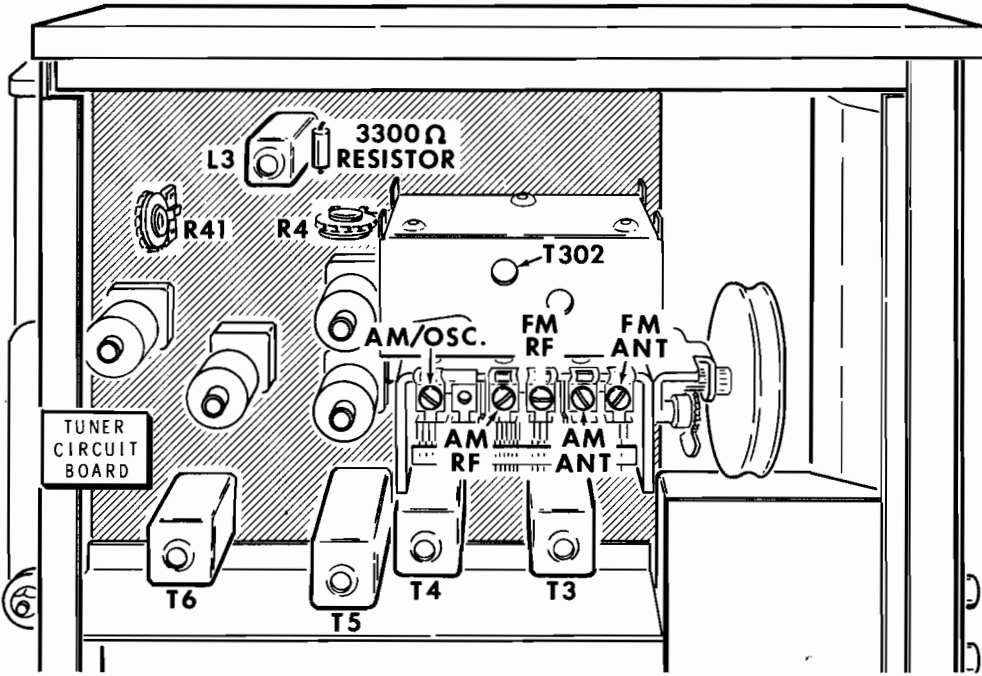

**Figure 1-1**

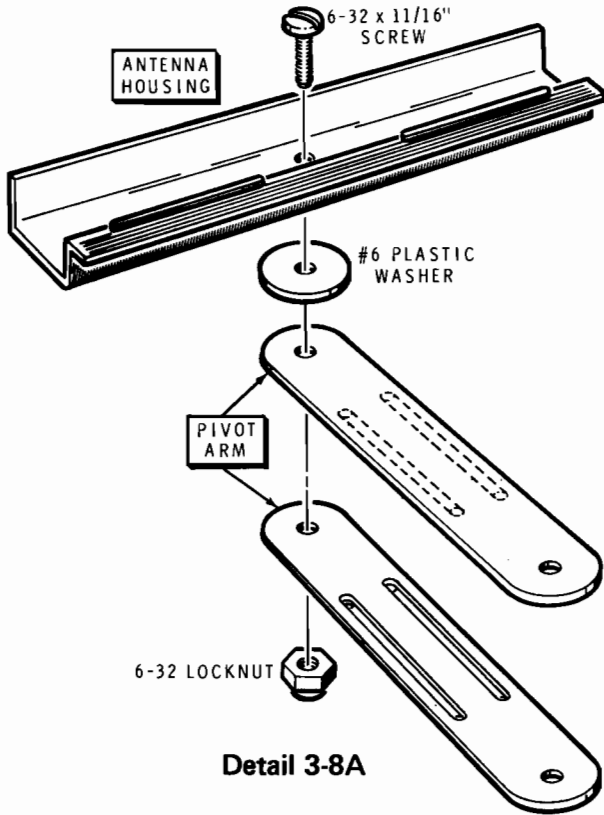

Detail 3-8A

**AM ANTENNA**

- ( ) Refer to Detail 3-8A and mount both pivot arms on one of the antenna housings with a 6-32 x 11/16" screw, a #6 plastic washer, and a 6-32 locknut. Tighten the hardware to the point where it requires a slight effort to turn the housing on the arms.

Refer to Detail 3-8B for the following steps.

- ( ) Cut two 1-3/4" lengths of foam tape. Remove the backing paper from each length of tape and wrap the tape around the ends of the rod antenna as shown. NOTE: The antenna leads should not be under the tape.
- ( ) Place a 9" length of sleeving on the red-green and the green leads of the rod antenna.
- ( ) Place a 9" length of sleeving on the red lead of the rod antenna. NOTE: Bend back the ends of the leads as shown to hold the lengths of sleeving in place.

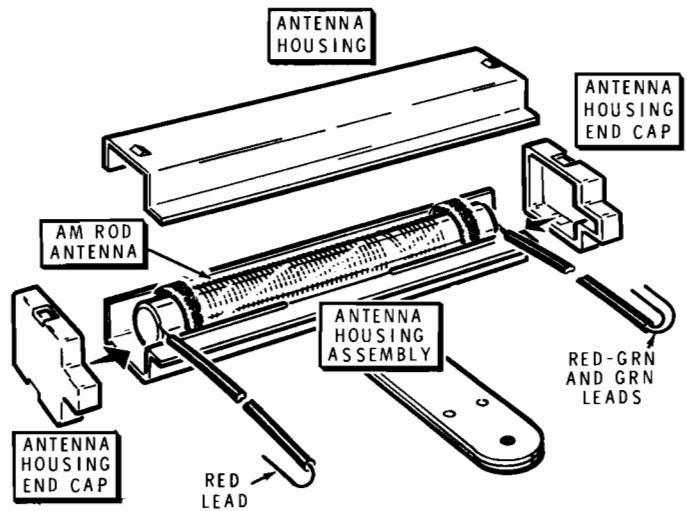

Detail 3-8C

- ( ) Refer to Detail 3-8C and place the rod antenna in the antenna housing assembly so the end with the red lead is toward the left. Then place the other antenna housing over the rod antenna and secure the housing to the antenna assembly with the two antenna housing end caps.

Refer to Detail 3-8D for the following steps.

- ( ) Position both antenna leads toward the pivot arms; then carefully press each lead into the groove formed between the two housings of the antenna assembly.
- ( ) Press the antenna housings together; then wrap two layers of plastic tape around the housings at the two locations shown. Position the tape in line with the edges of the pivot arms.

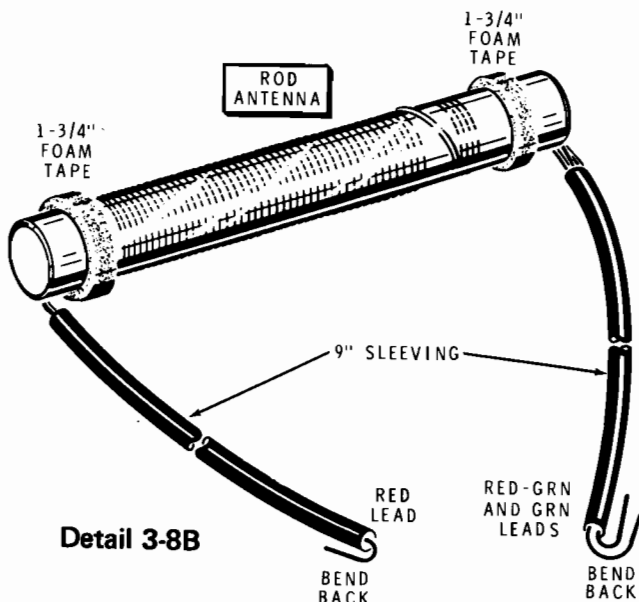

Detail 3-8B

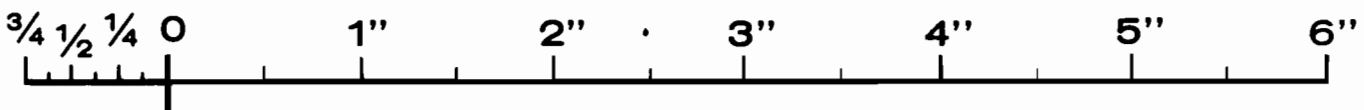

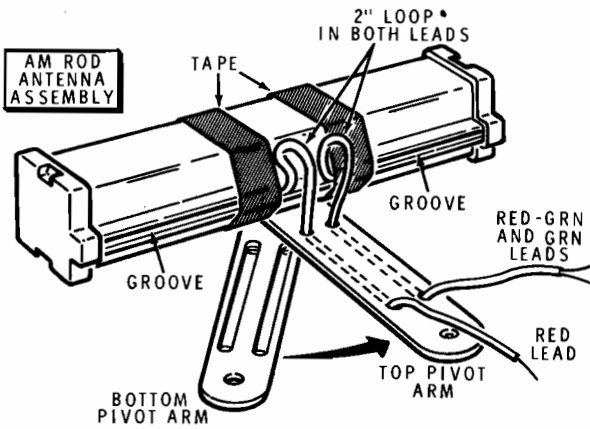

Detail 3-8D

- ( ) Move the bottom pivot arm aside as shown. Insert the antenna leads down through the indicated holes; then along in the pivot arm grooves and up through the holes near the end of the top pivot arm. CAUTION: Adjust the loops formed so there is approximately 2" of slack in each lead as shown.
- ( ) Move the bottom pivot arm toward the top pivot arm. Bend down slightly on the bottom arm and move it under the top pivot arm; then press the pivot arms together. Be sure the antenna leads are seated in the grooves in both pivot arms.

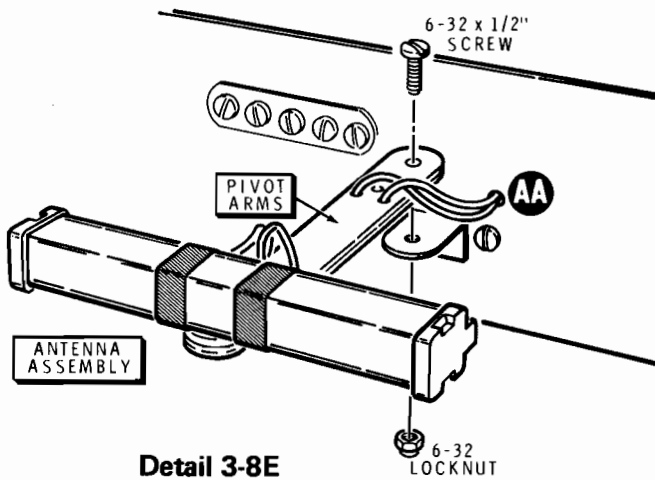

Detail 3-8E

- ( ) Refer to Detail 3-8E and mount the antenna assembly onto the antenna mounting bracket with a 6-32 x 1/2" screw and a 6-32 locknut. Tighten the hardware just enough to hold the antenna assembly in place, but loose enough to allow the antenna to be moved.
- ( ) Pass the rod antenna leads through hole AA. Leave sufficient slack to permit the antenna to be turned without damage to the leads. CAUTION: Do not turn the antenna more than 90° in either direction.

Refer to Pictorial 3-8 for the following steps.

- ( ) Turn the chassis upside down as shown.
- Connect the AM rod antenna leads extending from hole AA to terminal strip AB as follows:
- ( ) Green to lug 3 (NS).
  - ( ) Red-green to lug 2 (S-1).
  - ( ) Red to lug 1 (NS).
  - ( ) Prepare an 8" length of black wire. Connect this wire from lug 3 of terminal strip AB (S-2) to hole J in the tuner circuit board (S-1).

PART A

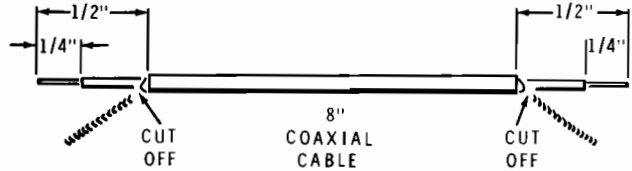

PART B



Detail 3-8F

- ( ) Refer to Part A of Detail 3-8F and prepare an 8" length of coaxial cable as shown.
- ( ) Then refer to Part B of Detail 3-8F and wrap two layers of plastic tape around each end of the cable as shown. Be sure to cover up the location where the shield lead was cut off.
- ( ) Connect this 8" coaxial cable from lug 1 of terminal strip AB (S-2) to lug 10 of the tuner assembly (S-1).
- ( ) Use a piece of plastic tape to tape the shielded cable to the center support bracket as shown in the Pictorial.

This completes the wiring of your Tuner. Carefully inspect all connections for loose wires or unsoldered connections. Remove any wire clippings or solder splashes. The remaining 3300 Ω (orange-orange-red) resistor will be installed later.

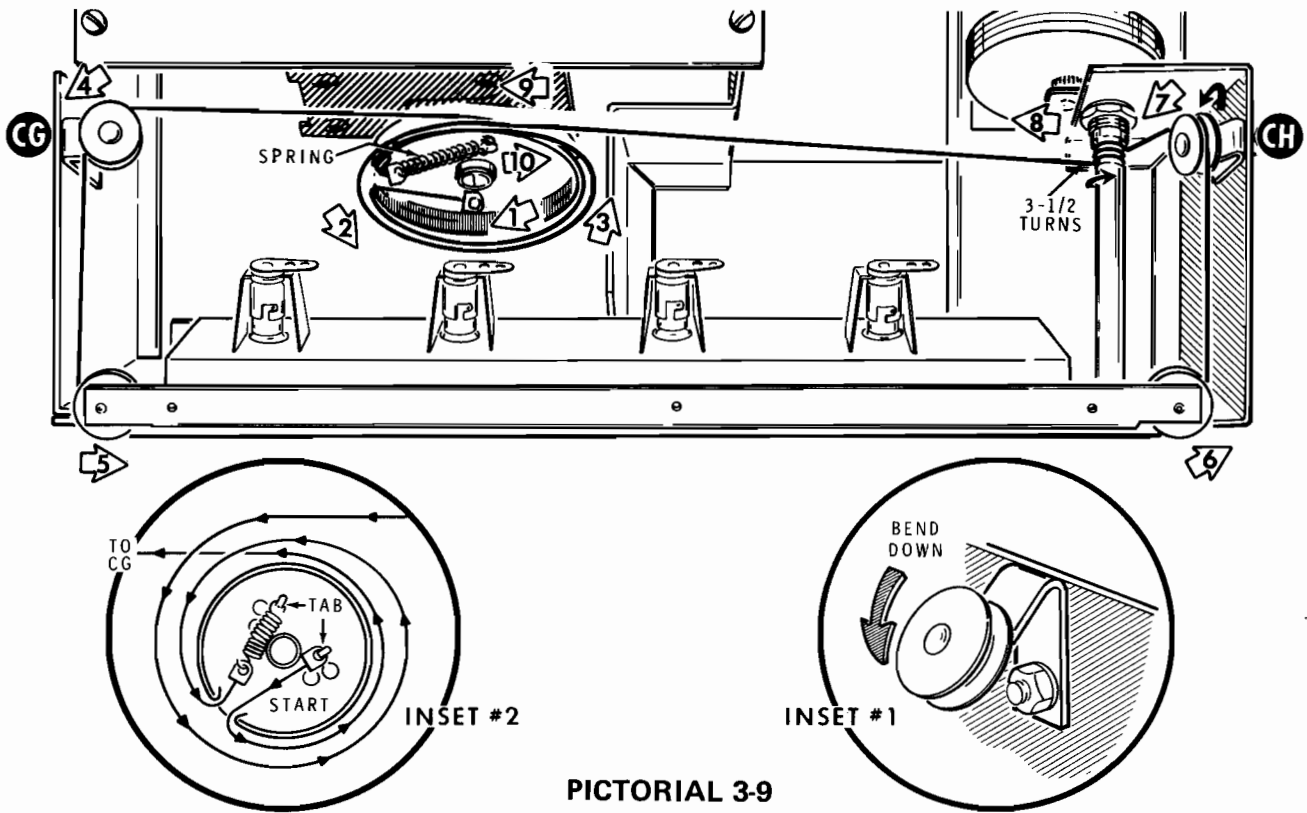

PICTORIAL 3-9

**DIAL INSTALLATION**

Refer to Pictorial 3-9 for the following steps.

- ( ) Bend the pulley assembly at CH down to the angle shown. See inset drawing #1.
- ( ) Bend the pulley assembly at CG down slightly as shown.
- ( ) Install the dial pulley on the shaft of the tuner assembly. Push the pulley on as far as it will go.
- ( ) Turn the dial pulley full counterclockwise.
- ( ) Fasten one end of the dial cord on the indicated tab of the dial pulley. Then follow the numbered arrows on Pictorial 3-9, starting at arrow #1, and complete the dial stringing. See inset drawing #2.
- ( ) Fasten the spring to the free end of the dial cord and the other tab of the dial pulley.
- ( ) Turn the dial shaft as far as possible in both directions to make sure the dial operates freely. Make any necessary adjustments to get proper alignment of the pulleys.

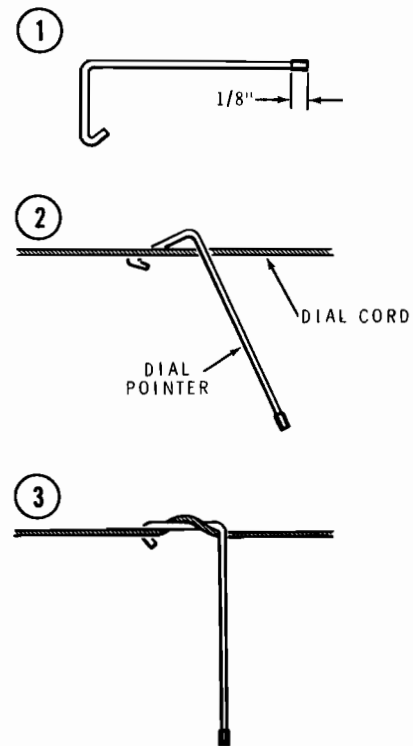

Detail 3-9A

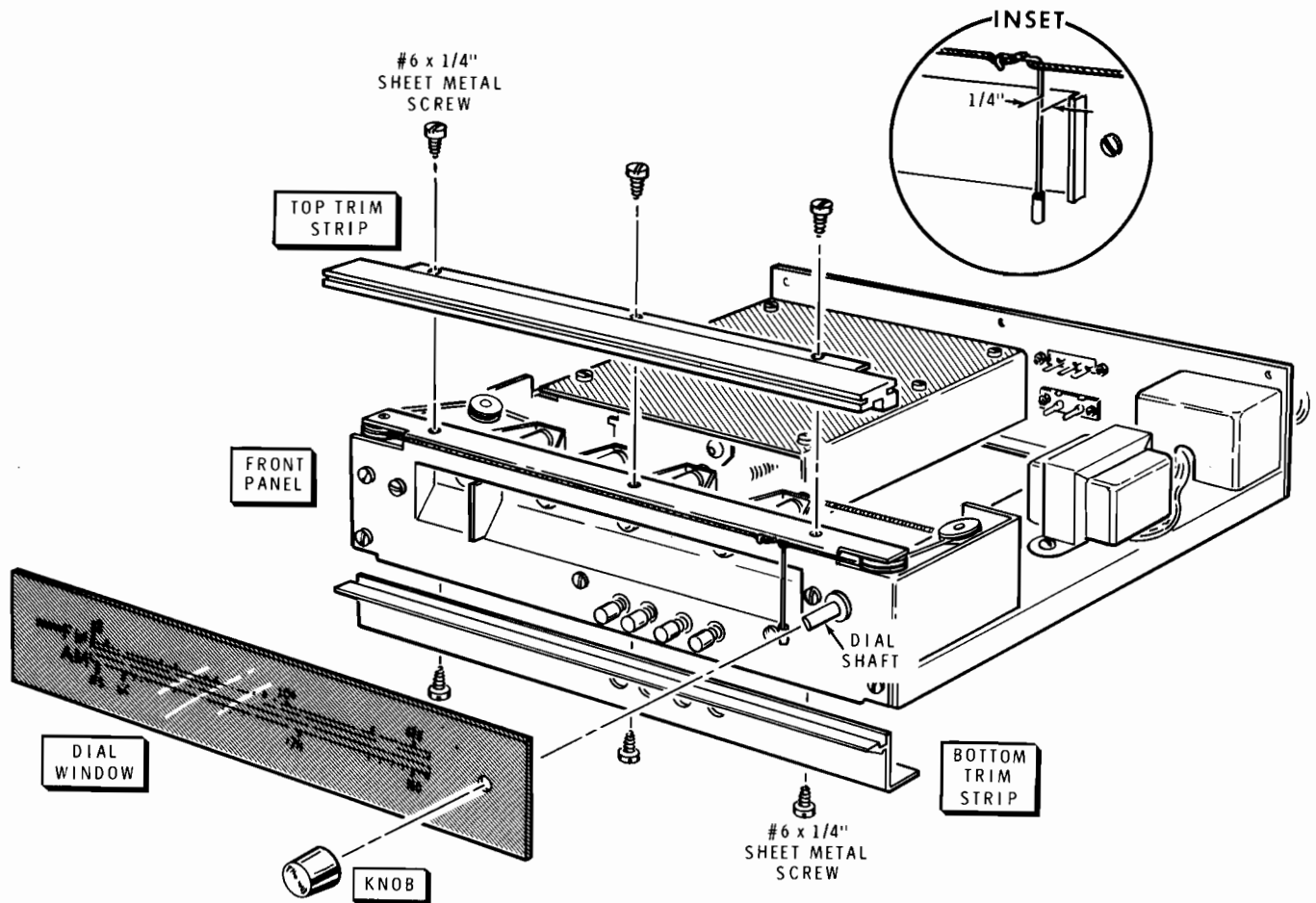

PICTORIAL 3-10

Refer to Detail 3-9A for the following steps.

- ( ) Remove 1/8" of insulation from a black stranded wire. Then slide the insulation on the end of the dial pointer as shown in part 1.
- ( ) Install the dial pointer on the dial cord as shown in parts 2 and 3.

Refer to Pictorial 3-10 for the following steps.

- ( ) Turn the dial shaft clockwise until the dial cord stops moving.
- ( ) Slide the dial pointer on the cord so it is positioned 1/4" from the right-hand side of the light shield, as shown in the inset drawing.

- ( ) Mount the bottom trim strip on the front panel with three #6 x 1/4" sheet metal screws.
- ( ) Install the dial window by fitting the hole in the dial window onto the dial shaft. Then fit the bottom edge of the dial window into the groove of the bottom trim strip.
- ( ) Fit the groove in the top trim strip onto the top edge of the dial window. Then secure the top trim strip to the front panel with three #6 x 1/4" sheet metal screws.
- ( ) Install the knob on the dial shaft.



# ADJUSTMENTS

## FM ADJUSTMENTS

Refer to Figure 1-1 (fold-out from Page 30) for the following steps.

- ( ) Temporarily solder a 7" length of solid wire between points A and F on the foil side of the tuner circuit board. Be sure the wire does not go through hole F far enough to touch the tuner assembly.
- ( ) Temporarily solder a 2" length of solid wire between points B and D on the foil side of the tuner circuit board.

NOTE: It will be easier to perform the following adjustments if you position the Tuner on its right (power transformer) end. Adjustments will be made from both the top and bottom of the Tuner.

- ( ) Connect the Tuner to your high fidelity system (see Page 41 for "Installation" instructions).
- ( ) Connect an FM antenna to the ANTENNA terminals of the Tuner. (Refer to Page 41 for information on antennas.)
- ( ) Set both controls (R4 and R41) on the tuner circuit board to the center of their rotation.
- ( ) Plug the line cord of the Tuner into an AC outlet.

NOTE: If the Tuner fails to perform according to the following steps, unplug the line cord and refer to the "In Case of Difficulty" section of the Manual. After you correct the problem, proceed with the "Adjustments."

- ( ) Remove the STEREO indicator lamp socket from the light shield. Position the socket (with its lamp) so it is easily seen, but so that its lugs do not touch the chassis or any other connection. The STEREO lamp will be used as an indicator while you make the following adjustment.
- ( ) Press the FM pushbutton to the ON position.
- ( ) Press the POWER pushbutton to turn the Tuner on. The three pilot lamps and the STEREO lamp should light.
- ( ) Tune in a weak FM station that causes the STEREO lamp to dim (see note below).

NOTE: If the stations are all too strong to cause the STEREO lamp to dim, connect the antenna across the 75 ohm terminals. If this still does not cause the light to dim, remove the antenna and hold your fingers on the antenna terminals, allowing your body to act as an antenna.

- ( ) Adjust the top and bottom slugs of transformer T302 for a minimum brilliance of the STEREO lamp. Rock the dial back and forth for minimum brilliance of the lamp while adjusting the transformer slugs. If the lamp goes out when you make the adjustment, tune to another station. Note that one slug can be reached from the foil side of the circuit board and one from the tuner.
- ( ) Repeat the previous step as many times as necessary until no further improvement can be noticed when adjusting either slug.



- ( ) Unplug the line cord.
- ( ) Remove the jumper from between locations A and F on the tuner circuit board.
- ( ) Remove the jumper from between locations B and D on the tuner circuit board.
- ( ) Permanently install a 1/2" jumper wire (all insulation removed) between locations D and E on the foil side of the tuner circuit board.
- ( ) Reconnect the line cord of the Tuner.
- ( ) Tune to a strong station and adjust the slug of coil L3 for the maximum and clearest sound output. Rock the tuner dial back and forth as before. **DO NOT TURN THE COIL SLUG MORE THAN 3/4 TURN IN EITHER DIRECTION.**
- ( ) Unplug the Tuner line cord.
- ( ) Install the 3300  $\Omega$  (orange-orange-red) resistor at its location on the tuner circuit board next to coil L3. Solder both connections and cut off the excess lead lengths.
- ( ) Reconnect the Tuner line cord.

NOTE: The dial pointer may not indicate the station where it should appear on the dial. For example, a station that is transmitting on 100 MHz may appear at 98 on the dial. Therefore, in the following steps you will adjust control R4 to correct this error.

- ( ) Tune in a stereo station of known frequency at the high end of the dial.
- ( ) If the dial pointer does not indicate the correct number on the dial for this station, adjust control R4 until the station appears at the correct place on the dial.
- ( ) Adjust control R41 until the STEREO light just turns on. Note the position of the control.
- ( ) Continue to turn this control in the same direction until the STEREO light goes out.
- ( ) Now turn the control in the opposite direction just until the stereo light turns on. Note the position of the control.
- ( ) Then, set this control midway between these two positions.
- ( ) Turn the Tuner off.
- ( ) Reinstall the STEREO lamp and socket back in its location in the light shield.

## AM ADJUSTMENTS

- ( ) Turn the tuning knob fully counterclockwise. CAUTION: DO NOT change the settings of the three FM adjustment screws on the tuner assembly when you make AM adjustments. The FM screws are preset, and if changed, instrument alignment will be required to get proper FM operation. You may wish to place pieces of tape over these three FM adjustment screws to prevent them from being turned accidentally.
- ( ) Turn the AM OSC, AM RF, and AM ANT screws on the tuner assembly, clockwise until they are just snug. Then loosen each screw 1/8 turn.
- ( ) Press the POWER switch to its ON position.
- ( ) Press the AM switch to its ON position.

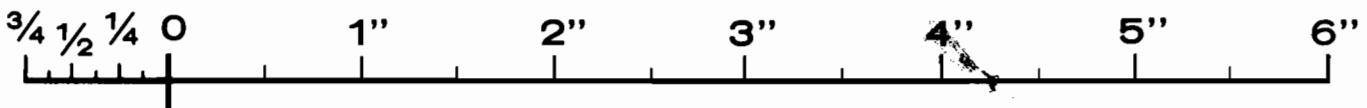



1. ( ) Tune to approximately 60 on the AM dial but not to a station.
2. ( ) Turn on a source of noise such as a fluorescent lamp or electric shaver.
3. ( ) Place the Tuner near the noise source so static can be heard from the speaker.
4. ( ) Adjust AM OSC transformer T4 for maximum noise.
5. ( ) Adjust AM RF transformer T3 for maximum noise.
6. ( ) Repeat steps 4 and 5 until no increase in noise can be detected.
7. ( ) Slowly turn the tuning knob clockwise until you hear an AM station.

**NOTE:** The best signal to use for the following adjustments is a weak station near 60 on the AM dial. However, you may use the first weak signal you receive as you turn the knob clockwise. Use the short end of the alignment tool to adjust the coil slugs in the following steps.

8. ( ) Adjust the slug of the AM IF transformer, T6, in both directions (no more than one turn in either direction) until the sound is loudest.
9. ( ) Alternately adjust the bottom and the top slugs of AM IF transformer T5 for the loudest sound.
10. ( ) If the previous two steps have increased the tuner sensitivity, turn the tuning knob to try and find a weaker station as near as possible to 60 (600 kHz)

on the AM dial. It may be necessary to turn the Receiver (antenna rod) slightly on your work surface to receive a weaker signal. Then repeat the previous two steps.

11. ( ) Tune in a station of known frequency near 140 (1400 kHz) on the AM dial.

If the dial pointer does not indicate the station frequency correctly, the AM OSC trimmer screw must be adjusted as directed in the following step.

12. ( ) Slowly turn the AM OSC screw (on the tuner assembly) as you move the tuning knob in the direction of the proper station frequency. Stop when the dial pointer indicates the frequency of the station that is tuned in.
13. ( ) Adjust the AM RF trimmer screw (on the tuner assembly) for the loudest sound.
14. ( ) Similarly, adjust the AM ANT trimmer screw (on the tuner assembly) for the loudest sound.

15. Repeat steps 1 through 6 as many times as necessary for maximum noise near 60 on the dial.

16. ( ) Recheck the tuning of the station near 140 on the dial. If the pointer is no longer on the correct point, repeat steps 12 through 14.

- ( ) Turn the Tuner OFF. Unplug the line cord, disconnect the antenna, and remove the cables that connect to the amplifier.

This completes the "Adjustments" of the Tuner. Proceed to the "Final Assembly" section.

# FINAL ASSEMBLY

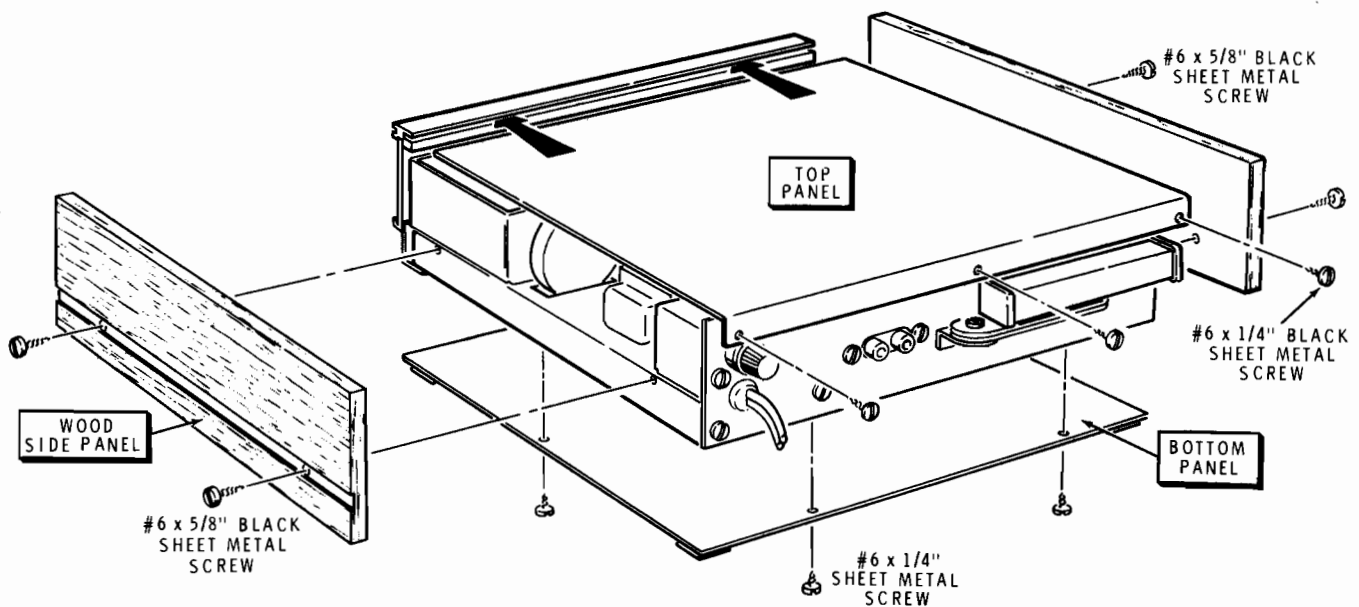

PICTORIAL 4-1

Refer to Pictorial 4-1 for the following steps.

- ( ) Install the bottom plate on the Tuner with six #6 x 1/4" sheet metal screws.
- ( ) Install the top panel with #6 x 1/4" sheet metal screws.
- ( ) Install the two wood side panels with four #6 x 5/8" sheet metal screws.
- ( ) Remove the paper backing from the four plastic feet and press the feet into place on the bottom plate. See Detail 4-1A.

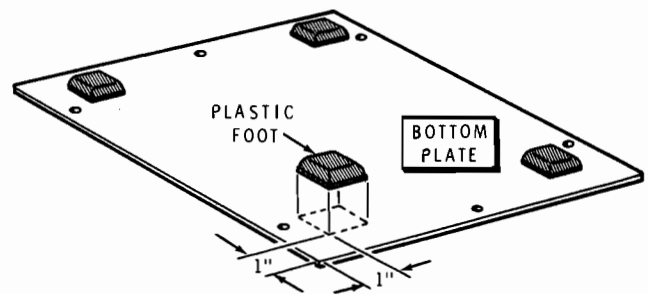

Detail 4-1A

This completes the assembly of your Tuner.

# INSTALLATION

## CONNECTING THE TUNER TO YOUR SYSTEM

Three connections must be made to the Tuner: an antenna, the power line, and an amplifier. Each of these is treated in a separate following section.

### ANTENNAS

#### AM Antenna

A built-in rod-type antenna is provided for AM reception. This antenna can be positioned for best reception. In some extremely strong signal areas, AM overload (distortion) may result. If this happens, position the rod antenna until the distortion disappears.

#### Indoor FM Antennas

Several types of indoor TV and FM antennas are available that will provide satisfactory mono FM operation of the Tuner in strong signal areas, or from strong local stations. For stereo FM, however, an outdoor antenna should be used.

A simple folded dipole antenna can be made as shown in Figure 2-1 from standard 300  $\Omega$  twin lead. This antenna can be nailed or stapled to a piece of wood to reinforce it. Best reception will be obtained from the stations that are broadside to this antenna. Weakest reception will occur with those stations that face the ends of the antenna.

#### Outdoor Antennas

To receive weak stations, in weak signal areas, an outdoor antenna will be necessary. BEST RECEPTION FOR

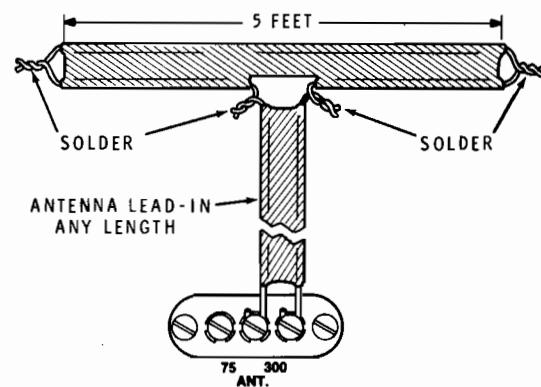

FOLDED DIPOLE ANTENNA  
MADE FROM 300 OHM TWIN  
LEAD TRANSMISSION LINE

Figure 2-1

STEREO FM WILL OCCUR WITH A COMMERCIAL FM OUTDOOR ANTENNA. A VHF TV antenna can also be used as an FM antenna because FM station frequencies are actually located between TV channels 6 and 7.

Do not connect a TV antenna to the TV set and the Tuner at the same time, unless a TV antenna coupler is used, or a weak and distorted signal may occur in both units. Pad type couplers are not recommended because large amounts of signal are lost in them. Use a preamplifier type of coupler instead, where there is no loss of signal.

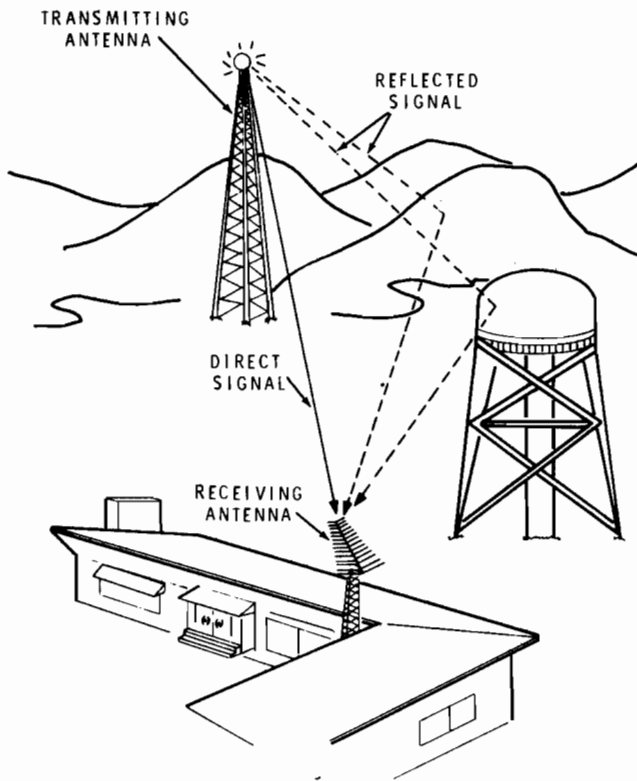

Figure 2-2

**Multi-Path Signals**

FM or FM stereo signals sometimes become noisy or distorted because they are reaching your antenna from several directions at the same time. See Figure 2-2. These multi-path signals are usually reflected from objects such as large buildings or large metal structures. This type of distortion can usually be eliminated or minimized by turning your antenna until it is receiving only one of these signals.

**External Connections**

Unwanted reflected signals may also be picked up on your antenna lead-in wire in strong signal areas. To eliminate this condition, connect your antenna lead-in to the antenna terminal strip as shown in Figures 2-3, 2-4, or 2-5.

**POWER LINE**

The line cord may be plugged into either a 120-volt or a 240-volt alternating current, 50 to 60 Hz, power source, depending upon how you wired the transformer primary circuit during assembly.

FOR A 300Ω TO 75Ω UNBALANCED ANTENNA HOOKUP, USE A MATCHING TRANSFORMER AND 75Ω SHIELDED CABLE.

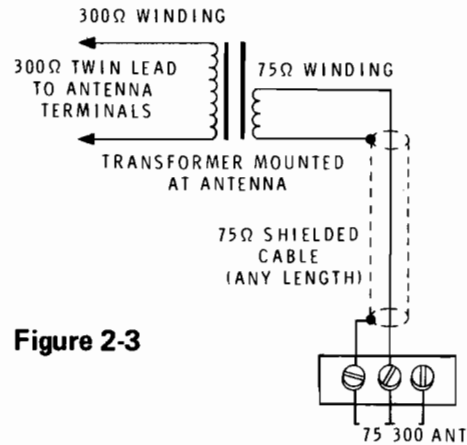

Figure 2-3

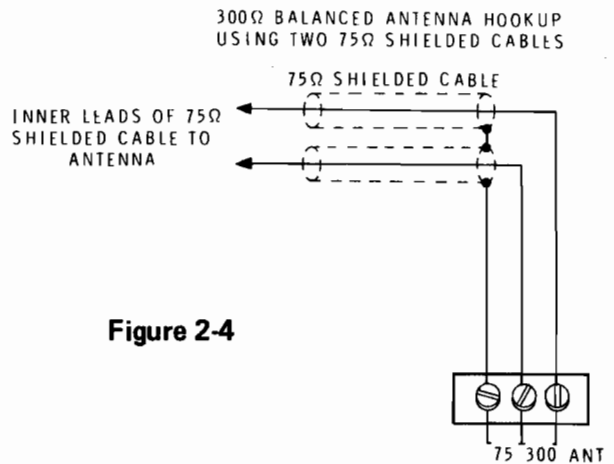

Figure 2-4

FOR 300Ω BALANCED ANTENNA HOOKUP USING 300Ω SHIELDED TWIN LEAD.

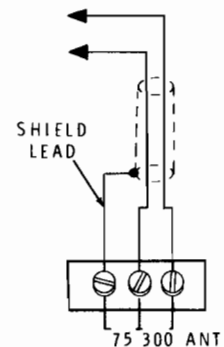

Figure 2-5

**AMPLIFIER**

Right and Left output connections are provided on the rear panel (see Figure 2-6). Connect these to corresponding input connections on your amplifier with good quality shielded audio cable. The type having phono plugs molded on each end is recommended.

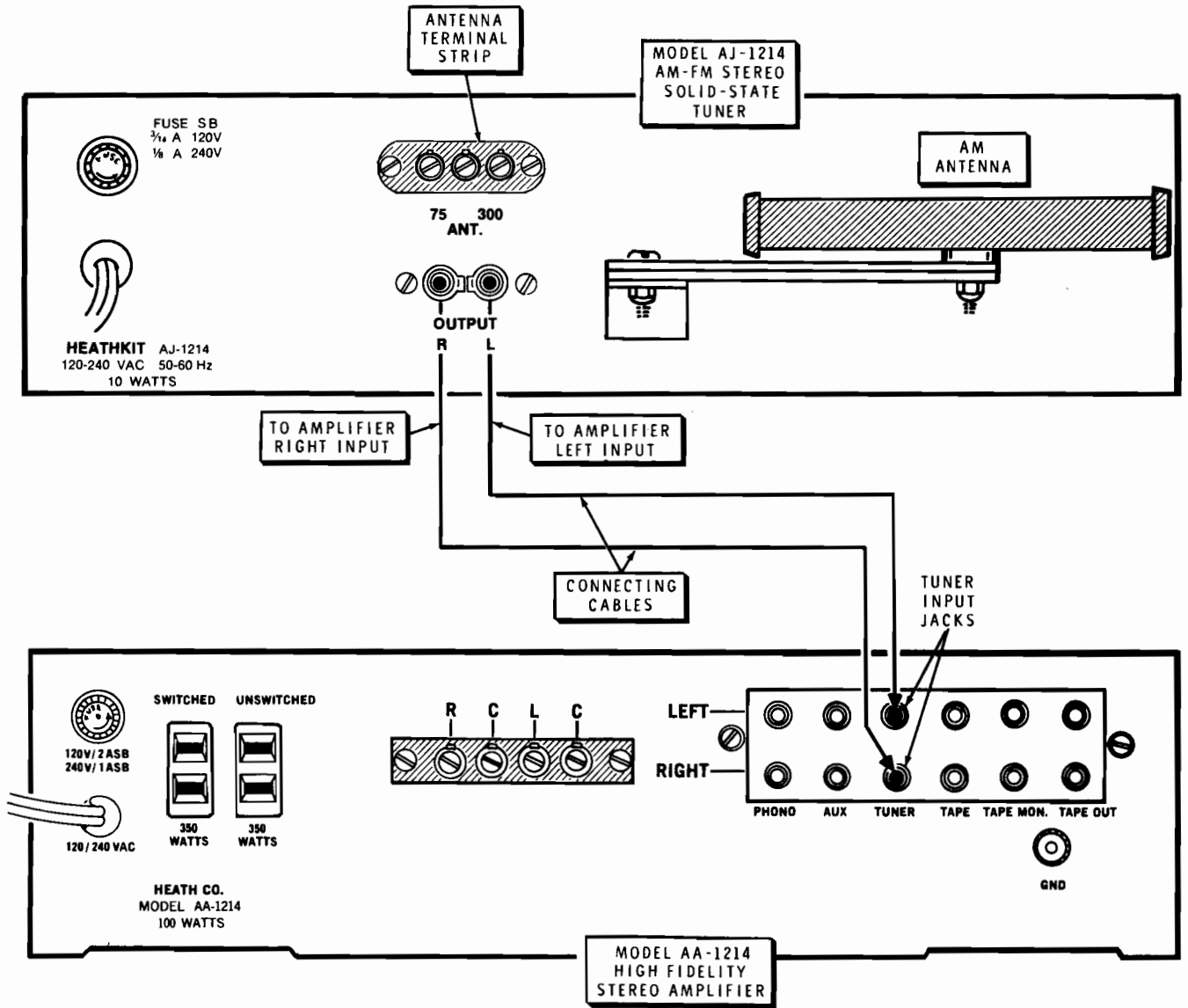

Figure 2-6

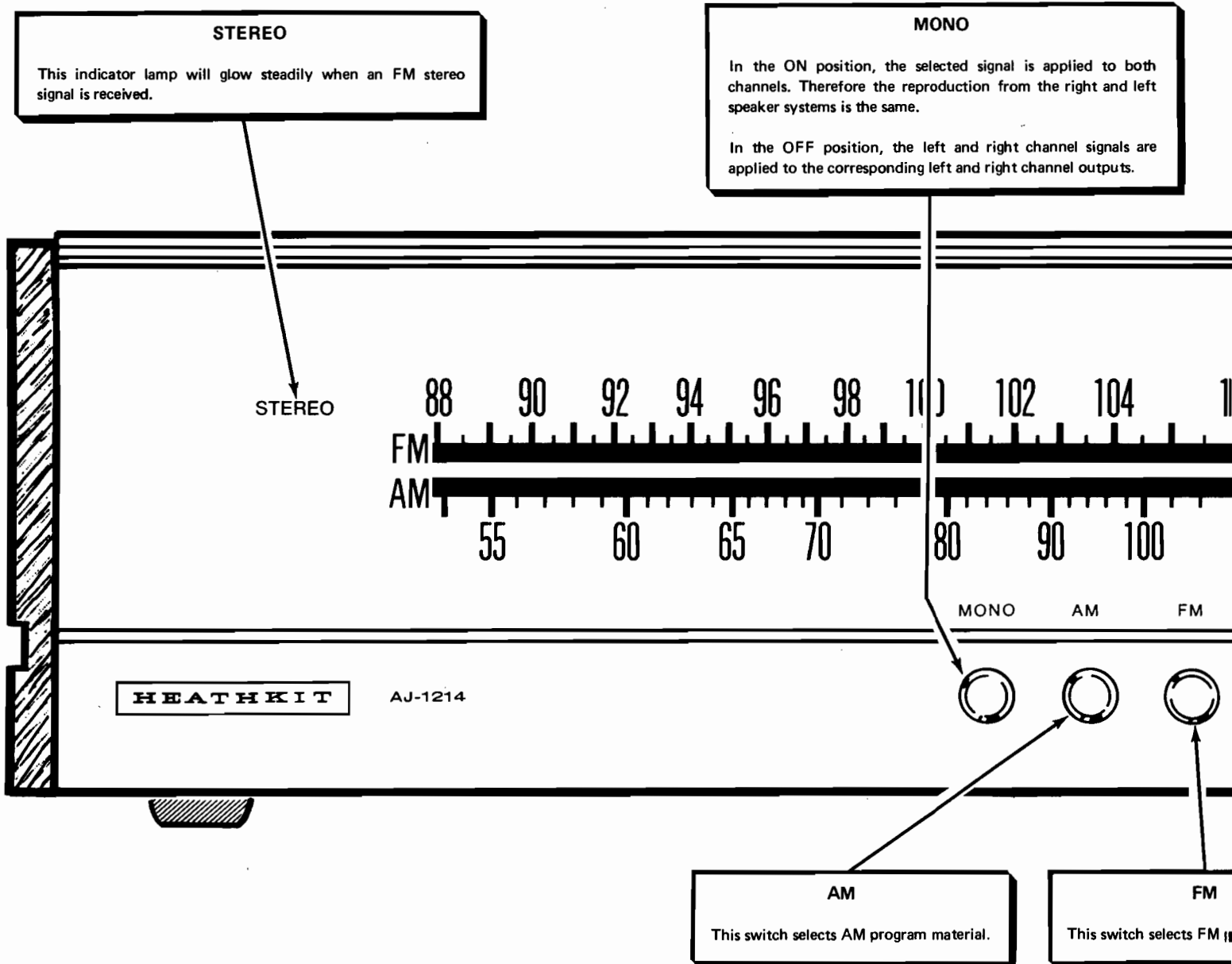

Figure 3-1



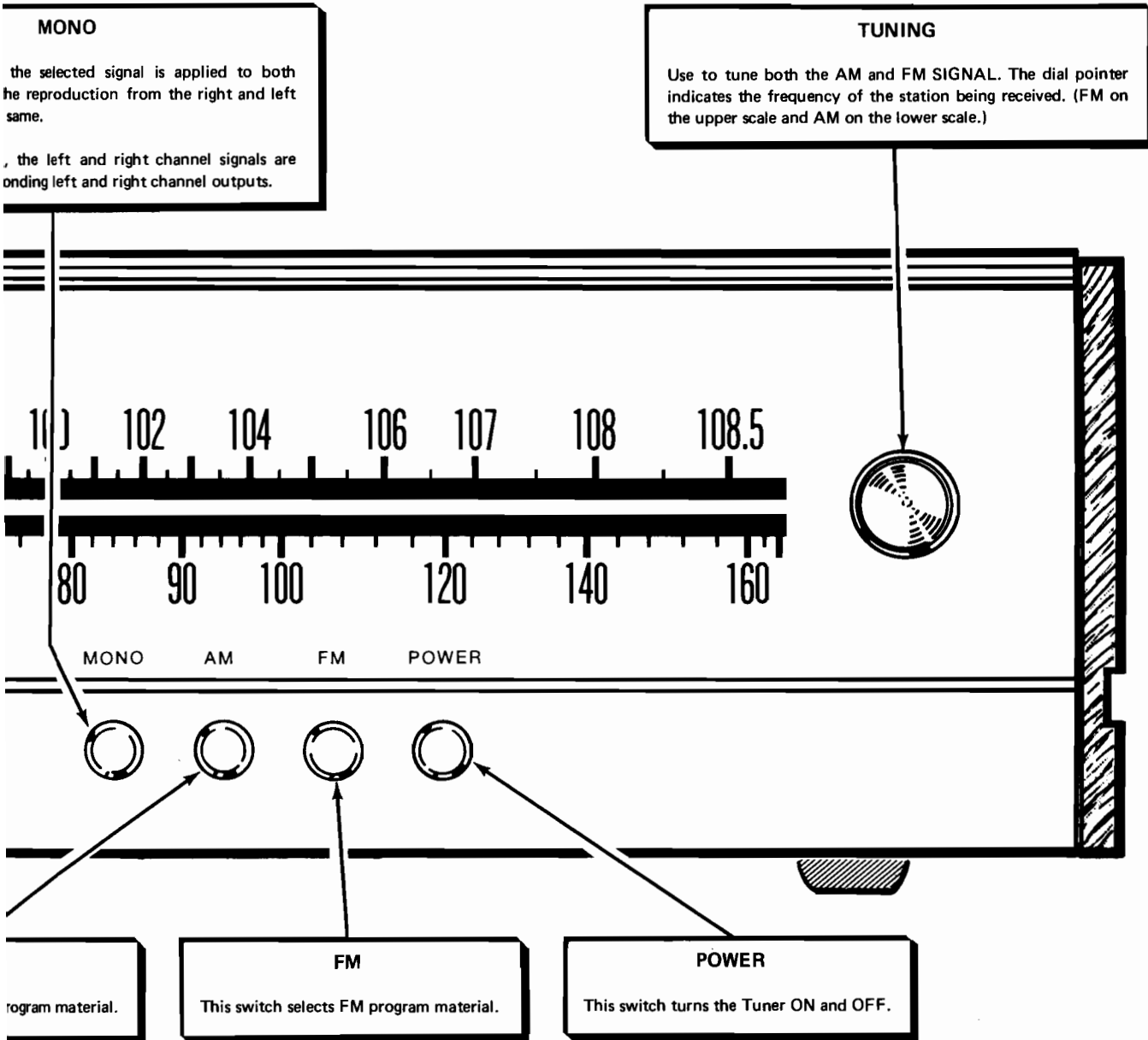

Figure 3-1

# OPERATION

## CONTROLS

The controls consist of the TUNING knob and a group of four pushbutton switches. Figure 3-1 illustrates the controls and describes the function of each.

Except for the AM and FM pushbuttons, place a switch in the ON position by pushing the button in until it latches. To return the switch to OFF, push the button in farther and

then release it. The AM-FM pushbuttons are interlocking; to release one, push in the other.

## TUNING

Push in the AM or the FM pushbutton to select the type of reception desired. Then rotate the TUNING knob to select a station. Use the AM or FM indicator scale, as appropriate, to determine the frequency of a station. The FM scale is calibrated in MHz and the AM scale in kHz.

# IN CASE OF DIFFICULTY

## GENERAL

### VISUAL CHECKS

1. About 90% of the kits that are returned for repair, do not function properly due to poor connections and soldering. Therefore, many troubles can be eliminated by a careful inspection of connections to make sure they are soldered as described in the Soldering section of the Kit Builders Guide. Reheat any doubtful connections and be sure all the wires are soldered at places where several wires are connected.
2. Check to be sure that all transistors are in their proper locations, and are installed correctly.
3. Check the value of each part. Be sure that the proper part has been wired into the circuit, as shown in the Pictorial diagrams and as called out in the wiring instructions. It would be easy, for example, to install a 2200  $\Omega$  (red-red-red) resistor in a step that calls for a 220  $\Omega$  (red-red-brown) resistor.
4. Recheck the wiring. Trace each lead in colored pencil on the Pictorial as it is checked. It is frequently helpful to have a friend check your work. Someone who is not familiar with the unit may notice something you have consistently overlooked.
5. Check all component leads connected to the circuit boards. Make sure the leads do not extend through the circuit board and make contact with other connections or parts, such as coil shields or the chassis.
6. Check all of the wires that are connected to the circuit board plugs. Make sure the wires do not touch the chassis or other lugs. Make sure all wires are properly soldered.
7. If the difficulty still is not found, read the "Precautions for Bench Testing" section, and the section titled "How to Troubleshoot Your Tuner."

### PRECAUTIONS FOR BENCH TESTING

1. Be cautious when testing transistor circuits. Although transistors have almost unlimited life when used properly, they are much more vulnerable to damage from excessive voltage or current than tubes. A vacuum tube can often be operated under shorted, zero-bias, excessive-voltage, or high-current conditions for short periods of time without materially damaging the tube. Any one of these conditions can destroy a transistor instantly.
2. Be sure you do not short any terminals to ground when making voltage measurements. If the probe should slip, for example, and short out a bias or voltage supply point, it is almost certain to cause damage to one or more transistors or diodes.
3. Do not remove transistors while the Tuner is turned on, as this could cause damage.
4. Do not remove circuit boards while the Tuner is turned on.

**CAUTION:** The full ac line voltage is present at several points (fuseholder, Power switch, etc.) in the power supply circuit. Be careful to avoid electrical shock when performing the checks described.



## HOW TO TROUBLESHOOT YOUR TUNER

If you know in which area your trouble lies, apply the Visual Tests listed to that area.

You may also go directly to the Troubleshooting Charts to see if the difficulty is described in one of the "Condition" columns. If your difficulty is listed there, check the "Possible Causes" for that item and apply the Visual Checks listed to the area of difficulty.

## REPAIRING THE TUNER

If you have occasion to make repairs to your Tuner, make sure you eliminate the cause as well as the effect of the trouble. For example, if you should find a damaged resistor be sure you find what it was (wiring error, etc.) that caused the resistor to become damaged. If the cause is not eliminated, the replacement resistor will also become damaged when the Tuner is put back into operation.

# Troubleshooting Charts

### POWER SUPPLY

CONDITION	POSSIBLE CAUSE
No voltage at collector of Q203.	<ol style="list-style-type: none"> <li>1. Fuse.</li> <li>2. Power transformer.</li> <li>3. Diode D201 or D202.</li> <li>4. Capacitor C204.</li> </ol>
Voltage low or 0 at emitter of Q203.	<ol style="list-style-type: none"> <li>1. Transistor Q201, Q202, or Q203.</li> <li>2. Capacitor C201 or C202.</li> <li>3. Diode D203.</li> </ol>
Voltage high at emitter of Q203.	<ol style="list-style-type: none"> <li>1. Transistor Q201, Q202, or Q203.</li> <li>2. Diode D203.</li> </ol>
Excessive hum in output.	<ol style="list-style-type: none"> <li>1. Diode D201 or D202.</li> <li>2. Capacitor C202, C203, or C204.</li> <li>3. Transistor Q201, Q202, or Q203.</li> </ol>

### FM SECTION

CONDITION	POSSIBLE CAUSE
No sound output. No AGC action.	<ol style="list-style-type: none"> <li>1. Transistor Q6.</li> <li>2. Diode D1 or D2.</li> <li>3. Filter F1.</li> <li>4. IC1.</li> <li>5. Tuner assembly.</li> </ol>
No sound output. No stereo light.	<ol style="list-style-type: none"> <li>1. Transistor Q3 or Q5.</li> <li>2. Filter F2.</li> <li>3. IC2.</li> <li>4. Coil L3.</li> </ol>
No sound output. Stereo light OK.	<ol style="list-style-type: none"> <li>1. Transistor Q7 or Q8.</li> <li>2. Coil L4, L5, L6, or L7.</li> </ol>

**AM SECTION**

CONDITION	POSSIBLE CAUSE
No sound output.	<ol style="list-style-type: none"><li data-bbox="862 359 1219 422">1. Transistor Q10, Q11, Q12, or Q13.</li><li data-bbox="862 422 1195 485">2. Transformer T3, T4, T5, or T6.</li></ol>

**NOTE:** In an extreme case where you are unable to resolve a difficulty, refer to the "Customer Service" information inside the rear cover of the Manual. Your Warranty is located inside the front cover of the Manual.

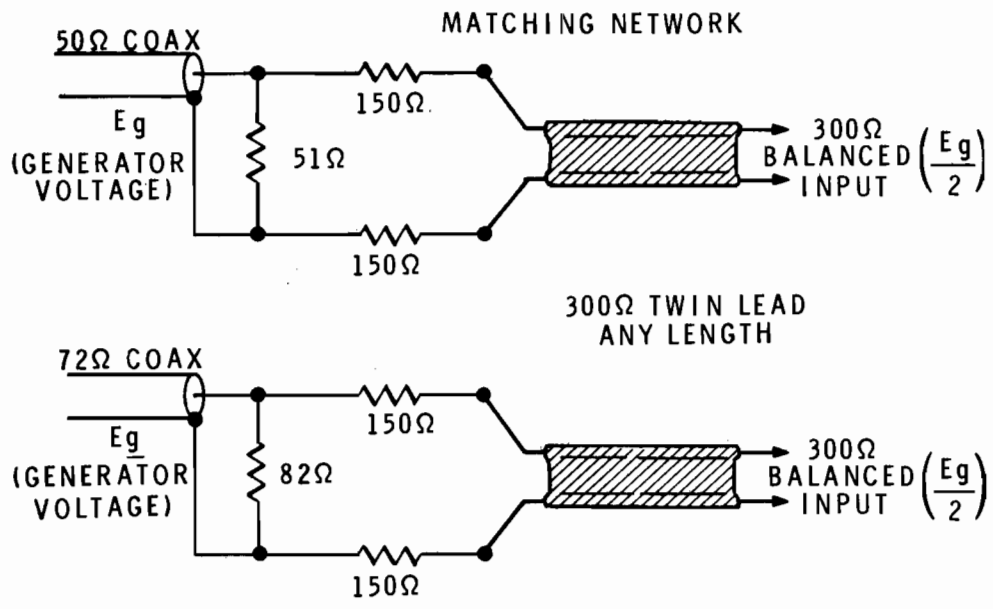

Figure 4-1

# ALIGNMENT WITH INSTRUMENTS

It is recommended that only persons familiar with instrument alignment perform the following adjustments, and then only if unsatisfactory operation occurs after the "Adjustments" on Page 35 are completed.

Refer to Figure 4-1 for the instrument connecting points and the location of the transformers, coils, and the capacitors to be adjusted in the following steps.

## FM ALIGNMENT

Equipment needed:

FM generator (must have less than .5% harmonic distortion).  
Audio voltmeter.  
DC voltmeter.  
FM stereo modulated generator.

- ( ) Preset all pushbutton switches to the OFF (out) position.

Now set the switches as follows:

- ( ) FM pushbutton: ON position.
- ( ) Control R4: center of rotation.
- ( ) Control R41: center of rotation.

### MIXER OUTPUT TRANSFORMER

- ( ) Connect the audio voltmeter to the tuner left or right OUTPUT jack and ground.
- ( ) Connect the DC voltmeter to point F (temporarily solder a short length of bare wire at point F) on the tuner circuit board and ground. Set the meter for a negative voltage.

- ( ) Set the FM generator center frequency to 98 MHz and the modulation selector switch to 400 Hz. Set the modulation control for a deviation of 75 kHz.
- ( ) Connect the FM generator to the tuner FM antenna terminals through a 300  $\Omega$  resistive matching network as shown in Figure 4-1.
- ( ) Plug in the tuner line cord and press the POWER pushbutton to ON.
- ( ) Carefully tune the Tuner to this 98 MHz signal. If necessary, adjust control R4 so the dial pointer is at exactly 98 MHz.
- ( ) Adjust the output of the FM generator for a -1 volt indication on the DC voltmeter.
- ( ) Adjust the top and bottom slugs of transformer T302 for a maximum DC voltmeter indication. Reduce the output of the FM generator as necessary to keep the DC voltmeter below -1.5 volts.
- ( ) Carefully turn the TUNING knob back and forth and again adjust T302 for a maximum DC voltmeter indication. Repeat this operation as many times as necessary until no improvement is noticed.

- ( ) Increase the FM generator output to 1000  $\mu$ V.
- ( ) Adjust coil L3 for a maximum indication on the harmonic distortion meter. Keep the Tuner peaked on the FM generator signal by carefully turning the TUNING knob back and forth.

**FM TUNER ASSEMBLY ALIGNMENT CHART**

STEP	FM SIGNAL GENERATOR		Receiver Dial Pointer Set to:	Audio Voltmeter Connected to:	DC Voltmeter Connected to:	Adjust for: Maximum DC Voltmeter Reading:
	Connected to:	Center Frequency and Output Level:				
1.	FM antenna terminals through 300 $\Omega$ matching network.	90 MHz at 4 $\mu$ V (see NOTE below).	90 MHz	Left or Right OUTPUT jack.	Point F.	1. L301. 2. T301.
2.	Same as step 1.	106 MHz at 4 $\mu$ V (see NOTE below).	106 MHz	Same as step 1.	Point F.	1. C317. 2. C308. 3. C302.
3.	Repeat steps 1 and 2 until no further improvement can be obtained.					
4.	Repeat "Mixer Output Transformer" steps.					

NOTE: Increase the generator output as necessary for initial readings; then reduce output to give a -1V meter reading.

- ( ) Substitute the FM stereo modulated generator for the FM generator. Use the matching network as before.
- ( ) Set the generator modulation to 400 Hz 100% modulation, left channel.
- ( ) If necessary, connect the audio voltmeter to the right channel OUTPUT jack.
- ( ) Adjust control R41 for a minimum signal which should be 40 dB, or more, down from the signal at the left channel OUTPUT jack.
- ( ) Turn the Tuner to OFF and disconnect all the test equipment. Proceed to "AM Alignment." Remove the wire from point F on the tuner circuit board.



# AM ALIGNMENT

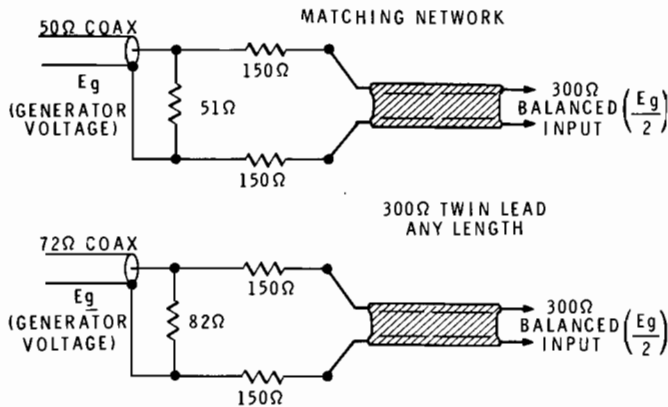

Figure 4-1 (Repeat)

Equipment needed:

AM signal generator with modulated RF output at 400 Hz and audio voltmeter.

Refer to Figure 4-1 for the location of transformers, coils, capacitors, and controls to be adjusted in the following steps.

- ( ) Connect the audio voltmeter to either the left or right OUTPUT jacks.
- ( ) Press the AM pushbutton to the ON position.

## ALIGNMENT CHART

		Connect AM Signal Generator to:	Set Frequency of AM Generator Modulated 30% at 400 Hz to:	Set AM Dial Pointer to:	Adjust for Maximum Deflection of the Audio Meter Pointer:
Adjust the generator output attenuator so the voltmeter reads 0.5 volt.	1.	Loosely coupled to rod antenna (lay hot lead of AM generator close to rod).	455 kHz.	Extreme low frequency end of dial.	1. Top and bottom slugs of T5 and the slug of T6.
	2.		600 kHz.	60 on AM dial.	*1. Slowly turn the dial pointer back and forth (on each side of the generator frequency) while adjusting the slug in coil T4. 2. Slug in T3.
	3.		1400 kHz.	140 on AM dial.	1. C301E – AM OSC. 2. C301D – AM RF. 3. C301C – AM ANT.
	4.	Repeat steps 2 and 3 until no further improvement is obtained.			

\*NOTE: Maximum meter deflection may be ±20 kHz from the station frequency.

This completes the "AM Alignment."

# SPECIFICATIONS

## FM SECTION (Monophonic)

Tuning Range . . . . .	88 to 108 MHz.
Intermediate Frequency (IF) . . . . .	10.7 MHz.
Frequency Response . . . . .	±1 dB, 20 to 15,000 Hz.
Antenna . . . . .	Balanced input for external 300 Ω antenna. 75 Ω antenna input may be used between either FM antenna terminal and ground.
Sensitivity . . . . .	2 μV.*
Volume Sensitivity . . . . .	Below measurable level.*
Selectivity . . . . .	60 dB.*
Image Rejection . . . . .	50 dB.*
IF Rejection . . . . .	75 dB.*
Capture Ratio . . . . .	2 dB.*
AM Suppression . . . . .	50 dB.*
Harmonic Distortion . . . . .	.5%.*
Intermodulation distortion . . . . .	.5%.*
Hum and Noise . . . . .	60 dB.*
Spurious Rejection . . . . .	70 dB.*

\*Rated IHF (Institute of High Fidelity) Standards



**FM SECTION (Stereophonic)**

Channel Separation . . . . .	40 dB typical. 35 dB.
Frequency Response . . . . .	±1 dB from 20 to 15,000 Hz.
Harmonic Distortion . . . . .	.75% at 1000 Hz with 100% modulation.
19 kHz and 38 kHz Suppression . . . . .	60 dB or greater.
SCA Suppression . . . . .	55 dB typical.

**AM SECTION**

Tuning Range . . . . .	535 to 1620 kHz.
Intermediate Frequency (IF) . . . . .	455 kHz.
Sensitivity . . . . .	100 $\mu$ V per meter.
Sensitivity . . . . .	40 dB (alternate channel).
AM Antenna . . . . .	Built-in rod type (adjustable).
Image Rejection . . . . .	75 dB at 600 kHz. 65 dB at 1400 kHz.
IF Rejection . . . . .	60 dB.*
Harmonic Distortion . . . . .	2%.
Hum and Noise . . . . .	35 dB.*

**GENERAL**

AM Output . . . . .	.6 volts nominal.
FM Output . . . . .	1 volt nominal.
Tuner Output Impedance . . . . .	3000 $\Omega$ FM. 1000 $\Omega$ AM.
Power Requirements . . . . .	105-125 or 210-250 VAC 50/60 Hz, 10 watts maximum.
Dimensions . . . . .	Overall — 13" wide x 3-5/8" high x 11" deep.
Net Weight . . . . .	7 lbs. 12 oz.

\*Rated IHF (Institute of High Fidelity) Standards.

---

The Heath Company reserves the right to discontinue instruments and to change specifications at any time without incurring any obligation to incorporate new features in instruments previously sold.

# CIRCUIT DESCRIPTION

Refer to the Schematic Diagram (fold-out from Page 67) while you read this "Circuit Description."

To help you locate a specific part in the Tuner or on the Schematic, the circuit part numbers (R1, C101, L301, etc.)

for resistors, capacitors, coils, and transistors are in the following groups:

0-99	Parts in the tuner circuit.
200-299	Parts in the power supply circuit.
300-399	Parts in the tuner assembly.

## FM CIRCUIT

### FM TUNER ASSEMBLY

FM broadcast signals (88 to 108 MHz) are received by the FM tuner assembly and converted to an IF frequency of 10.7 MHz. The tuner assembly contains an RF stage, a mixer stage, and an oscillator stage.

FM signals are coupled from an external 300 or 75 ohm FM antenna to the primary winding of transformer T301. The secondary winding of T301 is part of a tuned circuit which is tuned to the frequency of the desired station by variable capacitor C301A. The selected signal is then coupled through capacitor C304 to the gate of transistor Q301, amplified, tuned by a second  $L_c$  circuit consisting of coil L301 and variable capacitor C301B, and coupled through C309 to the base of mixer transistor Q302.

Oscillator transistor Q303 operates as a grounded-base oscillator. The oscillator frequency, which is 10.7 MHz above the incoming RF (tuned) signal, is determined by the tuning action of the oscillator tank circuit C301F and coil L302. A portion of the oscillator signal is coupled through

C321 to the base of mixer transistor Q302. The mixing of the tuned signal and oscillator signal in the mixer produces the 10.7 MHz IF signal which is then coupled through IF transformer T302 to the IF circuits.

### FM IF CIRCUIT

From T302, the signal is coupled to the first ceramic filter (FI) through a capacitive divider C19 and C21. The ceramic filter provides good selectivity for the IF signals and exceptional phase linearity for optimum multiplex performance. The output of the filter is fed to IC1 (integrated circuit #1).

IC1 has outputs at both pins 10 and 14. The output from pin 10 is coupled through capacitor C31 to the base of transistor Q6, and is amplified and coupled through capacitor C29 to rectifier diodes D1 and D2. After being rectified, the resultant negative DC voltage is filtered by capacitor C27, resistor R21, and capacitor C25. Then it is coupled to the tuner assembly to control the gain of transistor Q301.

The signal from pin 14 of IC1 is coupled to a second ceramic filter, F2. The output signal of F2 is connected to pin 1 of IC2. IC2 in this case is connected as a quadrature detector. Coil L3 causes a fixed delay of the signal between pin 10 and pin 12. The difference in phase between pin 12 and an internal connection is felt in the quadrature detector when the output is at pin 14 of IC1. Capacitor C36 at pin 14 of IC2 is a 10.7 MHz bypass. The remaining audio at this point is internally connected to an emitter follower with its output at pin 1 of IC2. Resistor R31 across L3 is to maintain a linear phase shift throughout the bandpass.

One of the two signal paths from pin 1 of IC2 is the AFC (automatic frequency control) signal. This signal is attenuated and the audio filtered out. The resultant voltage is coupled to the tuner assembly to compensate for any drift in oscillator Q303. Control R4 is used to correct for any frequency difference between the received signal and the dial calibration.

The other signal path is through capacitors C38 and C39 to transistor Q3 where the signal is amplified and then coupled through capacitor C40 to IC3.

### MULTIPLEX CIRCUITS

Left and right channel signals are produced by pickups at the radio station that is broadcasting FM stereo. The transmitting circuits then combine these signals to produce the L + R (main channel) signal shown in Figure 5-1A and the L - R (subchannel) signal shown in Figure 5-1B. Note that the L - R signal is superimposed on a 38 kHz signal as shown in Figure 5-1C. This amplitude modulated L - R signal is transmitted as the subcarrier channel.

The L + R (main channel) signal and the L - R (subcarrier) signal are combined with the 19 kHz pilot signal as shown in Figure 5-1D, and the whole complex signal modulates the transmitted RF carrier.

A second subcarrier signal is transmitted by some stations at a frequency of 67 kHz. This channel, which is modulated by a commercial music signal, is called the SCA (Subsidiary Communications Authorization) channel.

Figure 5-2 shows where the different components are to be found in a stereo FM signal. The L + R signal, which is in the audio spectrum (50 Hz to 15 kHz), is called the "main channel." Monophonic FM receivers use only this part of the signal, and the remaining signal components are attenuated by a de-emphasis network.

IC4 operates as a phase-lock multiplex demodulator with the left and right channel outputs at pin 5 and pin 4

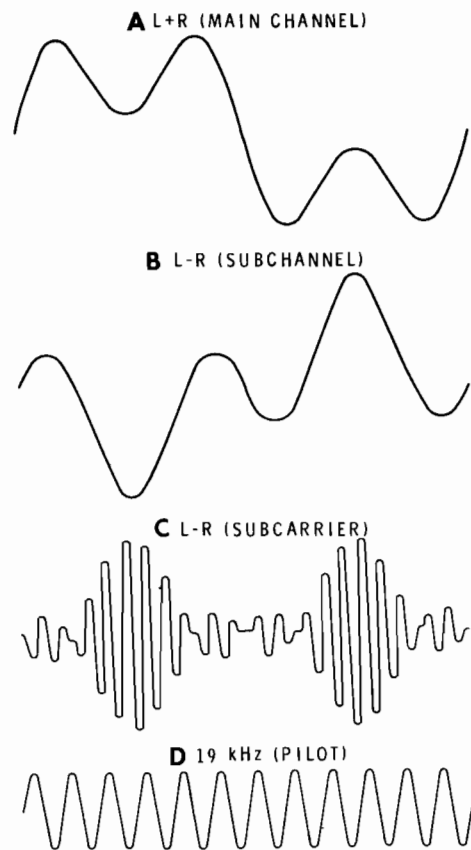

Figure 5-1

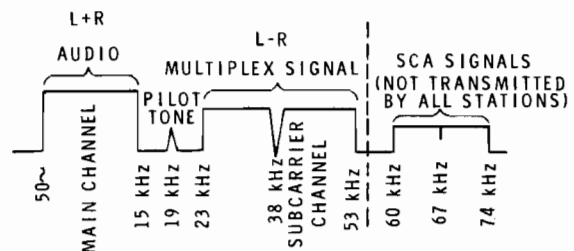

Figure 5-2

respectively. (Further information on the internal workings of IC3 can be obtained from the Motorola Company.) These outputs are fed through de-emphasis networks C47 and R43, and C48 and R42. The signals are then coupled to transistors Q7 and Q8 for amplification. Then the signals are passed through low pass filters to their respective output connectors. These filters remove any signals above 15 kHz.

Transistor Q14 is used as an AGC amplifier for adjustment purposes only.

## AM CIRCUIT

### RF AND MIXER CIRCUITS

The AM tuner consists of an RF amplifier, an oscillator-mixer, an intermediate frequency (IF) amplifier, a diode detector, and an audio amplifier. The AM tuner section allows you to receive standard broadcast signals from 535 kHz to 1620 kHz.

RF signals are picked up by rod antenna T2. The desired signal is selected by a tuned circuit that consists of one winding of T2 and the antenna section (C301C) of the variable tuning capacitor. The tuned signal is then coupled from the secondary winding of T2 through capacitor C1 to the base of RF amplifier Q10. Base bias for Q10 is supplied through resistor R1 from the AGC (automatic gain control) circuit.

From the collector of Q10, the signal is coupled through transformer T3 to the base of mixer transistor Q11. The primary winding of transformer T3 is tuned to the input signal frequency by the RF section (C301D) of the tuning capacitor.

Oscillator transformer T4 is tuned 455 kHz above the received signal by the oscillator section (C301E) of the

tuning capacitor. Feedback is coupled through capacitor C7 to the emitter of Q11 from the secondary winding of transformer T4. The input signal at the base and the oscillator signal at the emitter are mixed together in transistor Q11 to produce a 455 kHz difference (IF) signal.

### IF AND DETECTOR CIRCUITS

The 455 kHz IF signal is coupled through IF transformer T5 to the base of transistor Q12. After being amplified by transistor Q12, the IF signal is coupled by IF transformer T6 to the detector circuit, which consists of diode D3, capacitor C15, and resistor R13.

The detected audio signal is filtered by resistor R14 and capacitor C16. The signal is then coupled by capacitor C55 to audio amplifier transistor Q13, and through capacitor C18 and AM switch S203 to the output jacks.

The detected signal also develops the AGC voltage that is used to control the gain of transistors Q10 and Q12. This voltage is developed across resistor R13 and is filtered by resistors R12 and R14, and by capacitors C13 and C16. Automatic gain control helps to maintain a constant audio output level in spite of fading or varying RF signals.

## POWER SUPPLY

The primary of power transformer T201 can be connected for either 120 VAC or 240 VAC operation. The tapped secondary of T201 provides approximately 33 volts for rectification by full wave rectifier D201 and D202. These diodes, in conjunction with capacitor C204, provide a filtered DC voltage for the voltage regulator.

The voltage regulator, consisting of transistors Q201, Q202, Q203 and associated components, operates as follows:

Resistor R205 and capacitor C203 filter the DC voltage that operates Q201. Resistor R206 is a load for transistor Q201, diode D203 determines the voltage at which Q201 will operate, and resistor R202 keeps Q201 turned on. Capacitor

C202 prevents noise generated by D203 from getting into the regulator.

Transistor Q202 allows Q201 to operate at a very low current. Resistor R204 limits the current if the power supply becomes shorted. If a short does occur, the emitter to base current of Q203 exceeds that amount allowed by R204, and the power supply turns off.

The voltage divider consisting of resistors R201 and R203 sets the voltage at which the power supply is to operate. If the output goes positive, Q201 will conduct more and the base of Q202 will drop as will the base of Q203. Therefore, less current will flow through the transistors and the output voltage will return to its normal potential. Thus the power supply is self regulated.

# CHASSIS PHOTOGRAPH

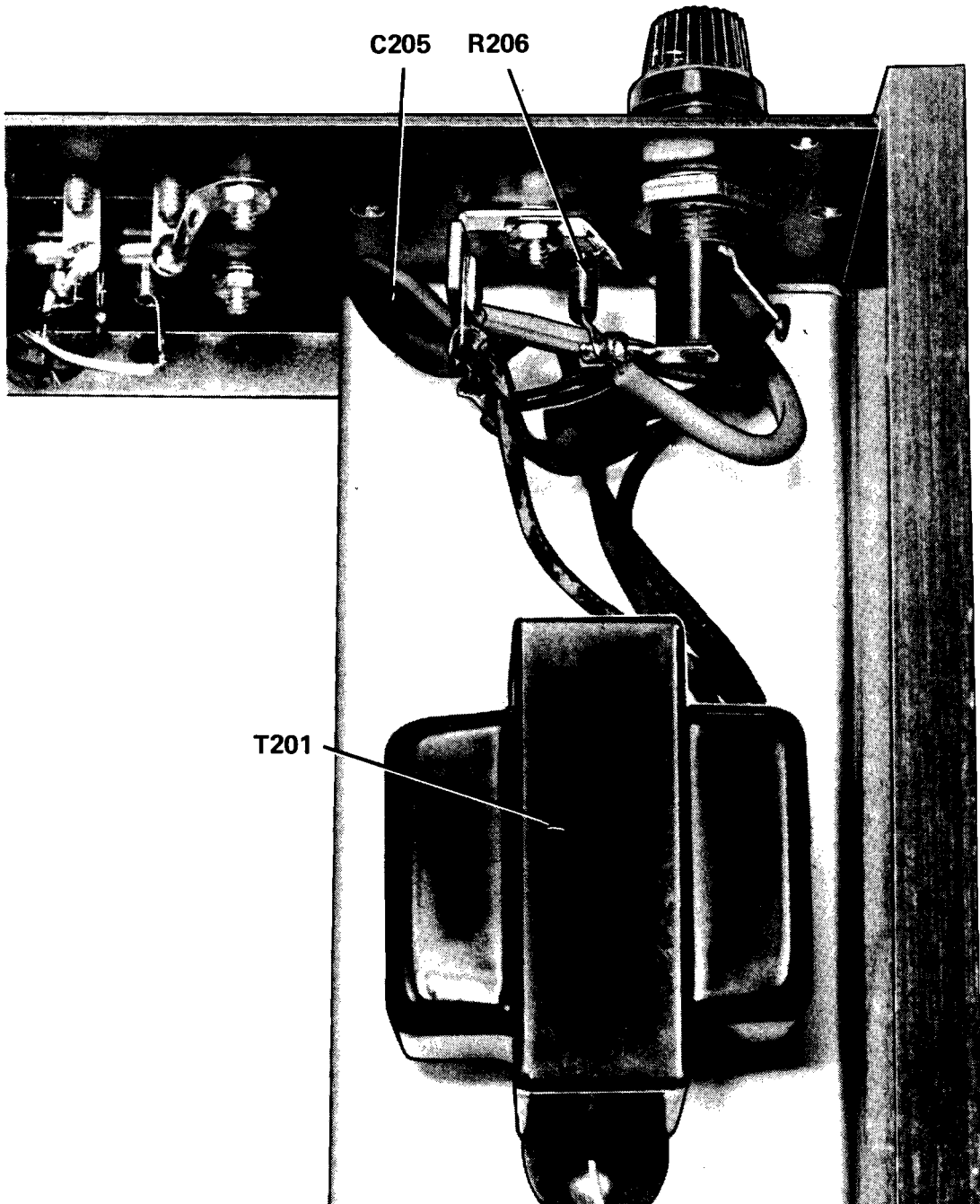

# CIRCUIT BOARD X-RAY VIEWS

NOTE: To identify a part shown in one of these Views, so you can order a replacement, proceed as follows:

1. Note the identification number of the part (R-number, C-number, etc.).
2. Locate the same identification number (next to the part) on the Schematic. The "Description" of the part (for example: 22 k $\Omega$ , .05  $\mu$ F, or 2N2712) will also appear near the part.
3. Look up this Description in the Parts List.

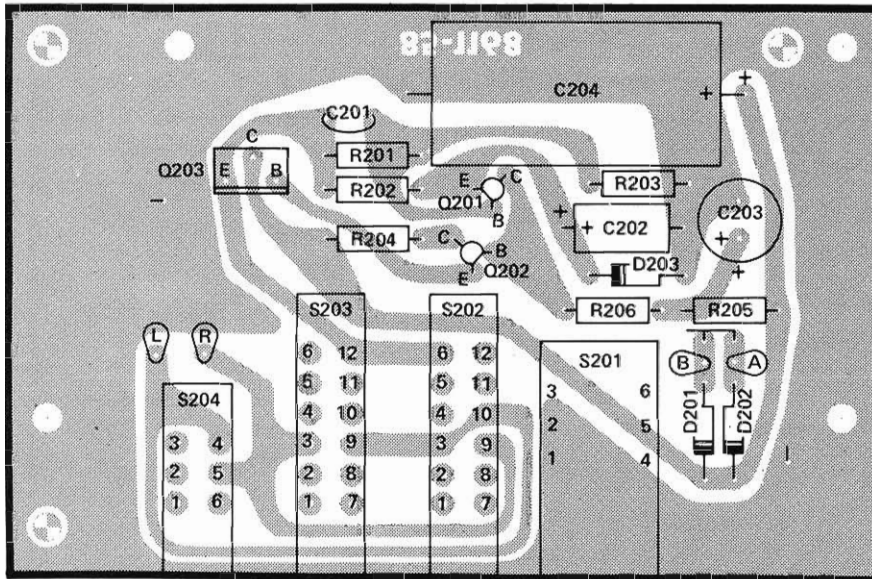

(SHOWN FROM COMPONENT SIDE)

(SHOWN FROM FOIL SIDE)

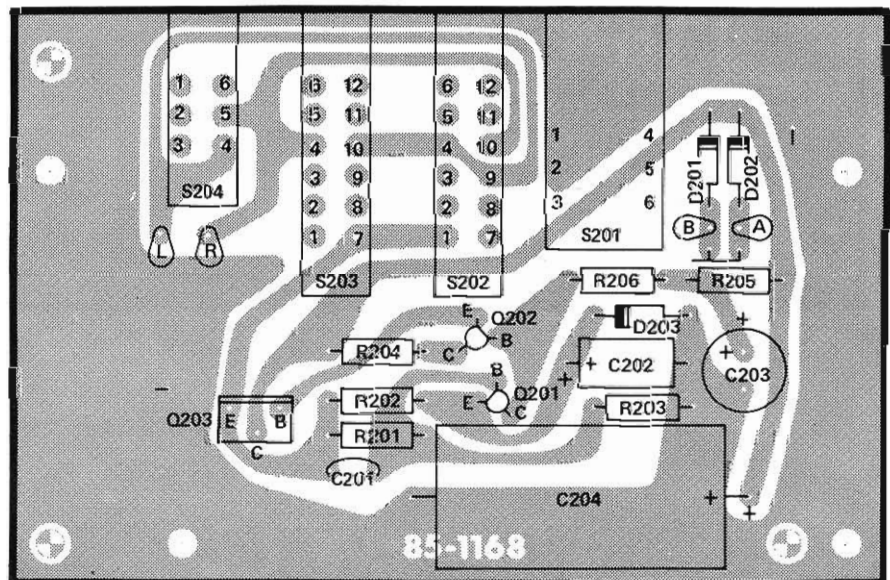



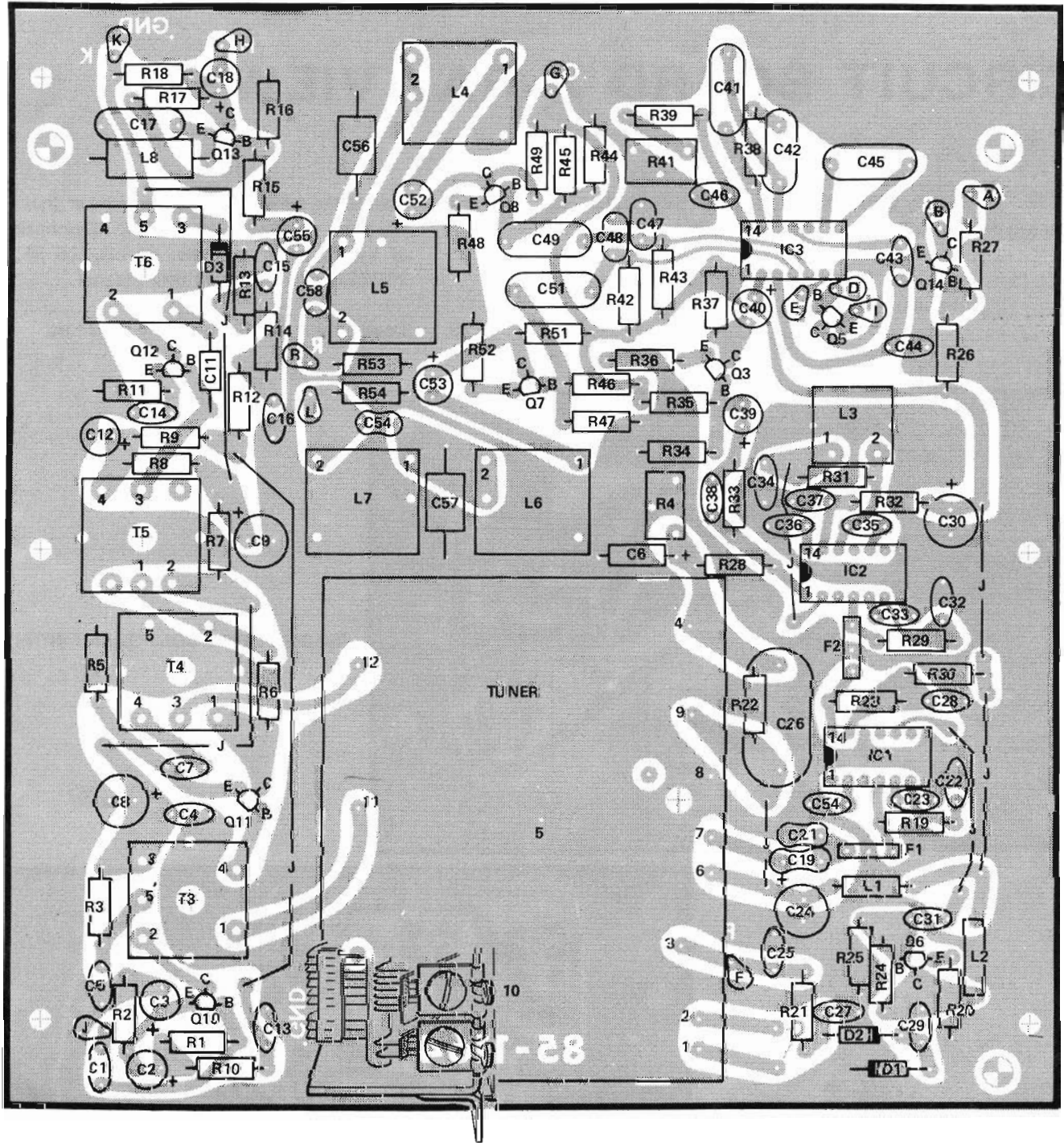

(SHOWN FROM COMPONENT SIDE)

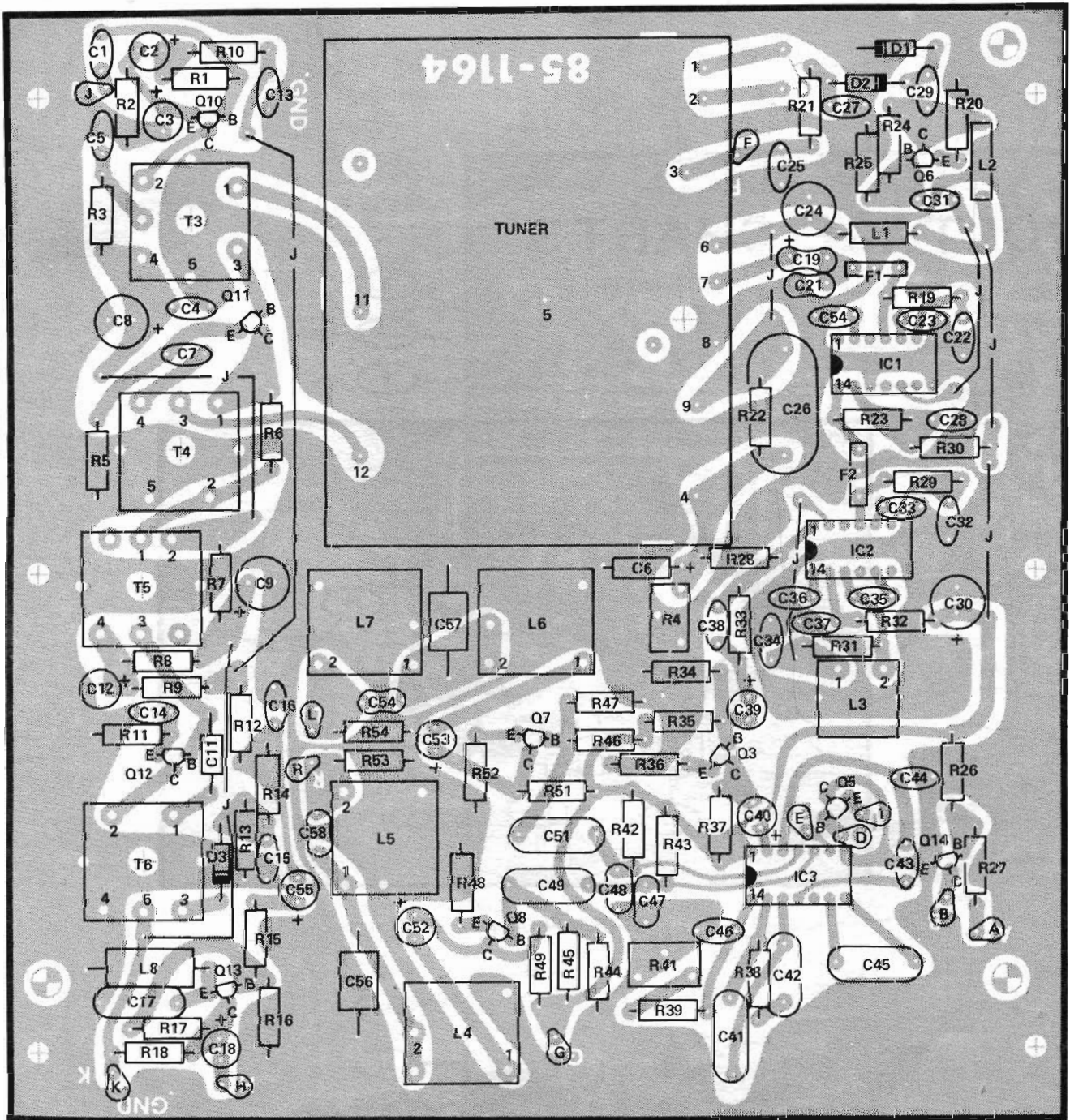

(SHOWN FROM FOIL SIDE)

# VOLTAGE CHARTS

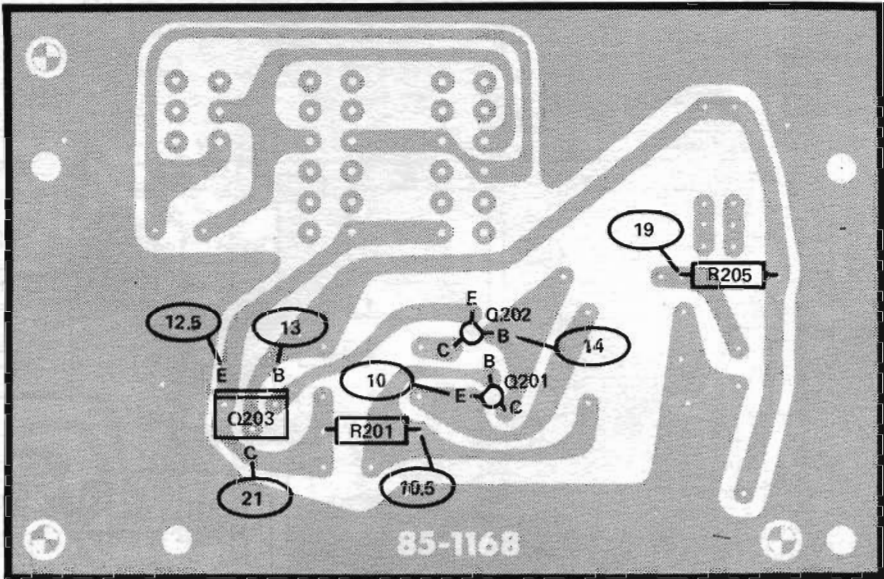

(SHOWN FROM FOIL SIDE)

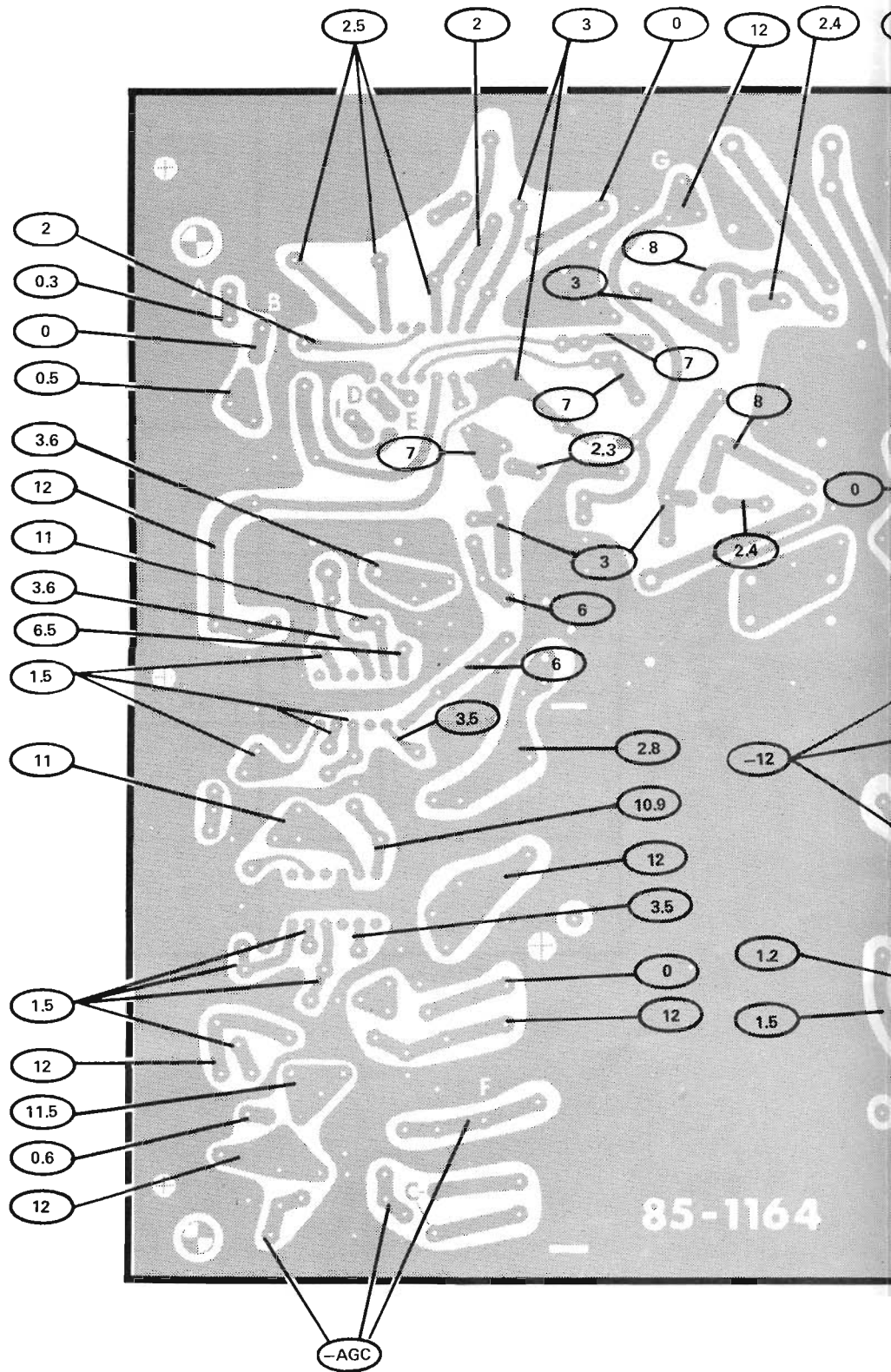

(SHOWN FROM FOIL SIDE)



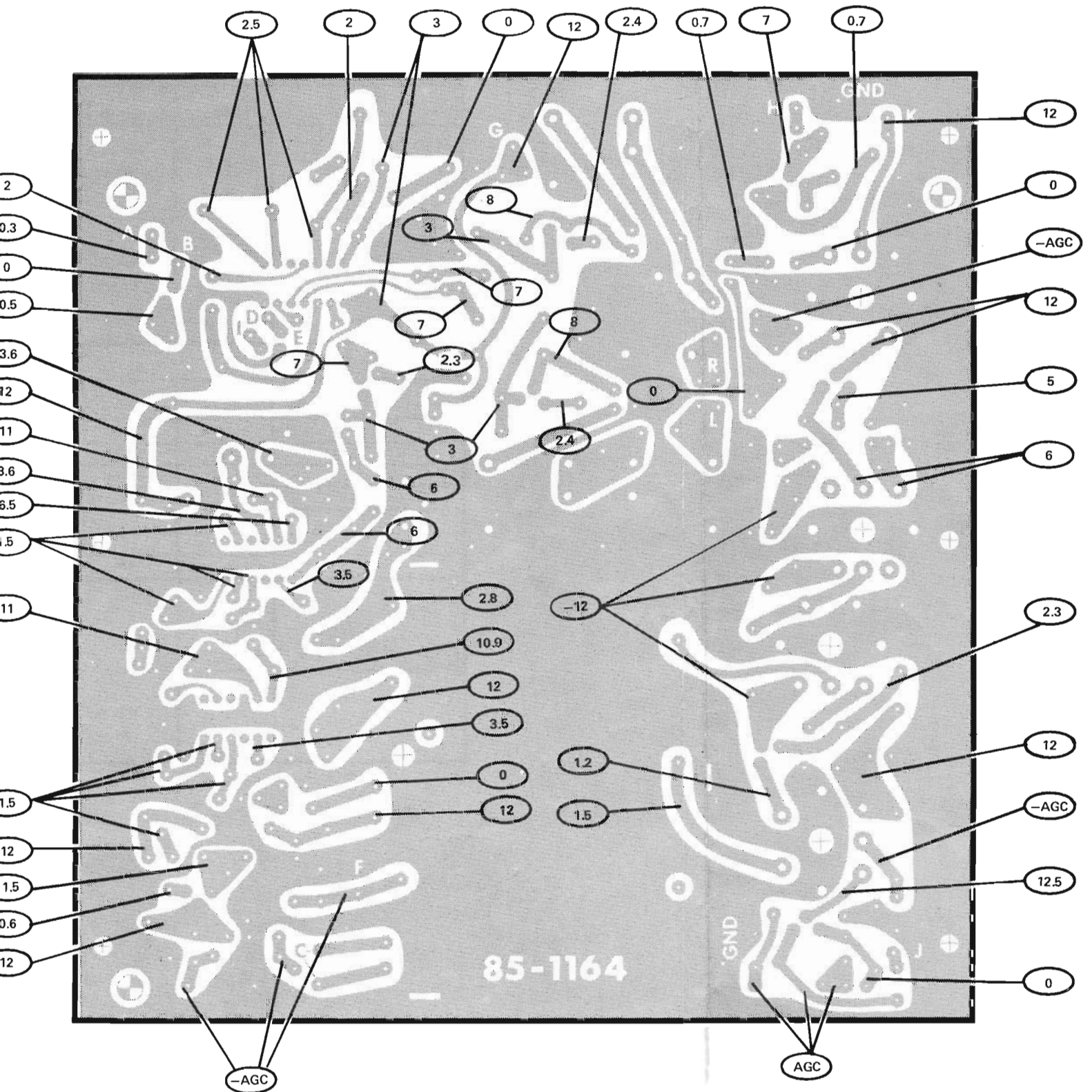

(SHOWN FROM FOIL SIDE)

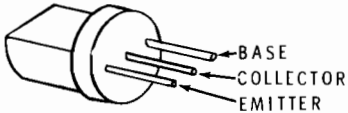
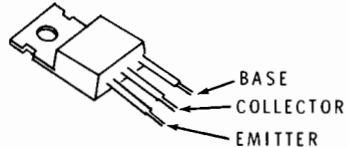
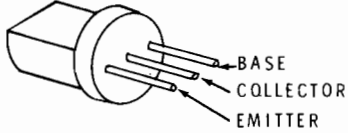
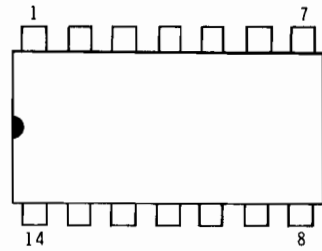
POWER SUPPLY CIRCUIT BOARD			
SCHEMATIC Q NUMBER	HEATH PART NUMBER	MANUFACTURER'S NUMBER	BASING
Q201, Q202	417-118	2N3393	
Q203	417-175	2N5294	
TUNER CIRCUIT BOARD			
SCHEMATIC Q NUMBER OR IC NUMBL	HEATH PART NUMBER	MANUFACTURER'S NUMBER	BASING
Q10	417-83	L842	
Q11	417-84	E843	
Q12	417-85	E844	
Q6, Q13, Q14	417-118	2N3393	
Q7, Q8	417-91	2N5232A	
Q3	417-213	2N5249A	
Q5	417-201	X29A829	
IC3	442-46	MC1310	
IC1, IC2	442-28	MC1357	

**NOTES:**

1. RESISTOR AND CAPACITOR NUMBERS ARE IN THE FOLLOWING GROUPS:
  - 0-99 PARTS ON THE TUNER CIRCUIT BOARD.
  - 200-299 PARTS ON THE POWER SUPPLY CIRCUIT BOARD.
  - 300-399 PARTS IN THE TUNER ASSEMBLY.
  - POWER SUPPLY PARTS MOUNTED ON THE CHASSIS.
2. REFER TO THE CHASSIS PHOTO AND X-RAY VIEWS FOR THE PHYSICAL LOCATION OF PARTS.
3. ALL RESISTORS ARE 1/2 WATT. RESISTOR VALUES ARE IN OHMS (K=1000, M=1,000,000).
4. ALL CAPACITOR VALUES LESS THAN 1 ARE IN  $\mu\text{F}$ . ALL CAPACITOR VALUES OF 1 OR ABOVE ARE IN  $\mu\text{F}$  UNLESS MARKED OTHERWISE.
5. DC VOLTAGE MEASUREMENTS WERE TAKEN WITH A HIGH IMPEDANCE INPUT VOLTMETER FROM THE POINT INDICATED TO THE CHASSIS GROUND. VOLTAGES MAY VARY  $\pm 20\%$ .
6. FM CIRCUIT VOLTAGE READINGS WERE MADE WITH THE FM PUSH-BUTTON IN THE "ON" POSITION. AM CIRCUIT VOLTAGE READINGS WERE MADE WITH THE AM PUSHBUTTON IN THE "ON" POSITION.
7. THIS SYMBOL INDICATES A DC VOLTAGE UNDER NO SIGNAL CONDITIONS.
8. THIS SYMBOL INDICATES CIRCUIT BOARD GROUND.
9. THIS SYMBOL INDICATES CHASSIS GROUND.
10. THIS SYMBOL INDICATES A DIRECT CONNECTION FROM THE TUNER ASSEMBLY TO THE TUNER CIRCUIT BOARD.
11. THIS SYMBOL INDICATES A CONNECTION TO A CIRCUIT BOARD.
12. THIS SYMBOL INDICATES A CONNECTION TO THE TUNER ASSEMBLY.

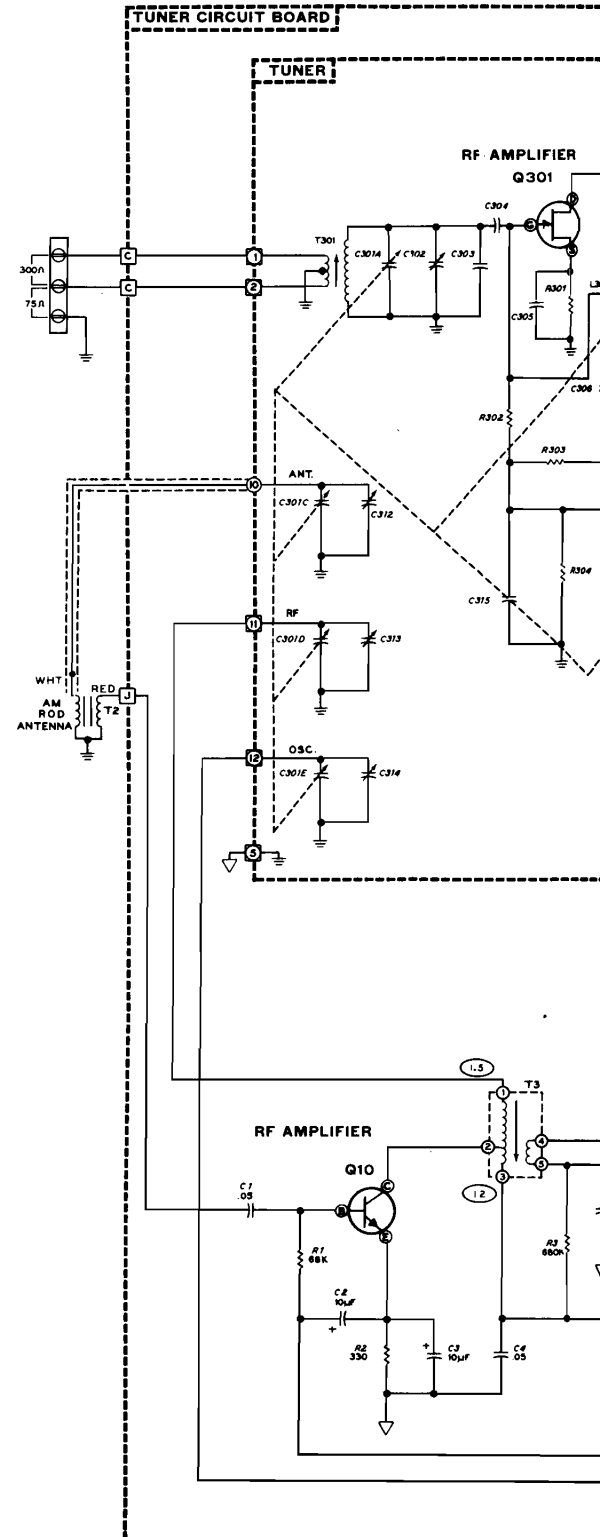

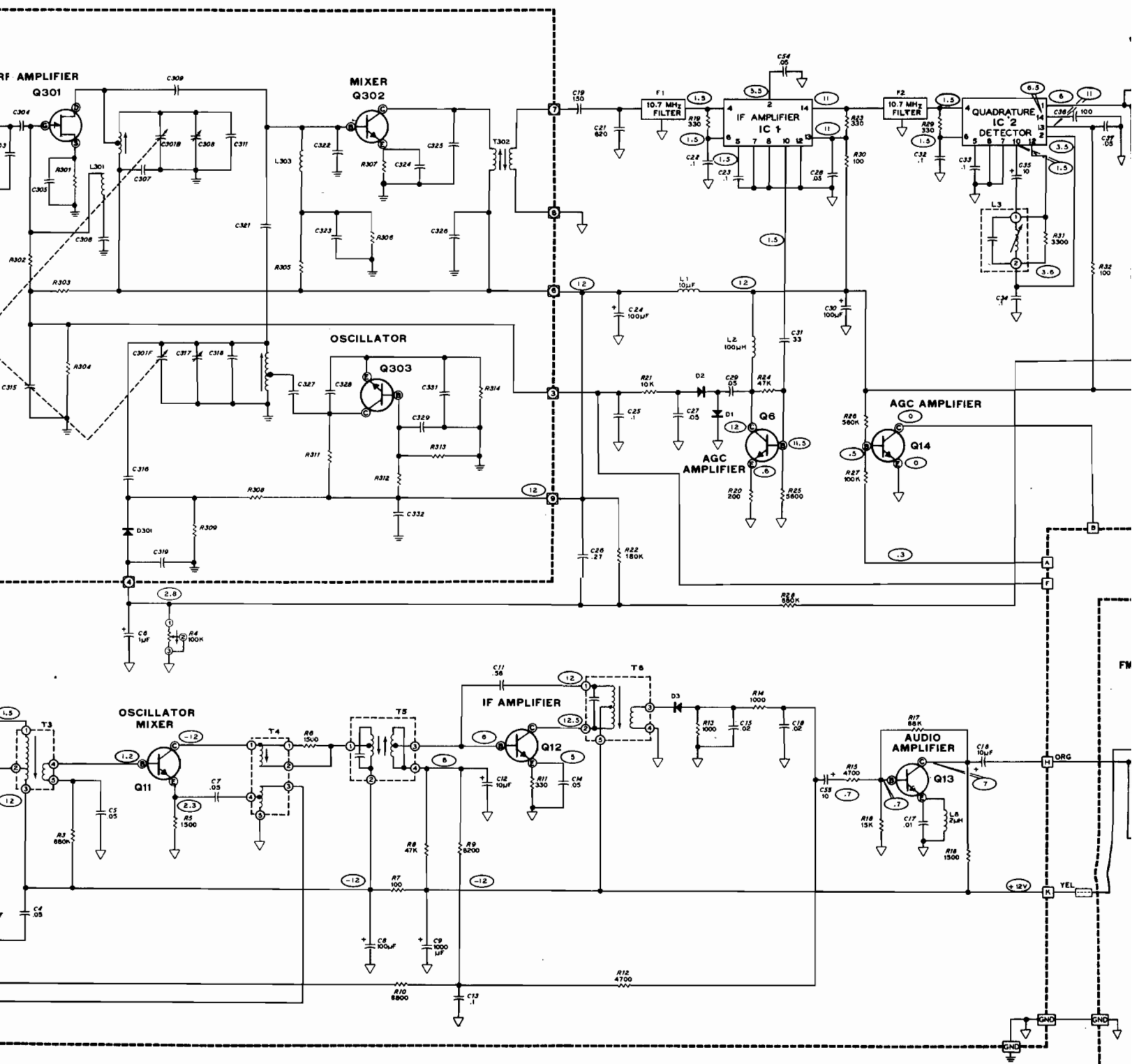

**SCHEMATIC OF THE**  
**HEATHKIT®**  
**AM-FM STEREO TUNER**  
**MODEL AJ-1214**

POWER



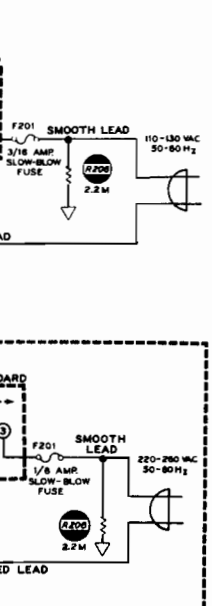
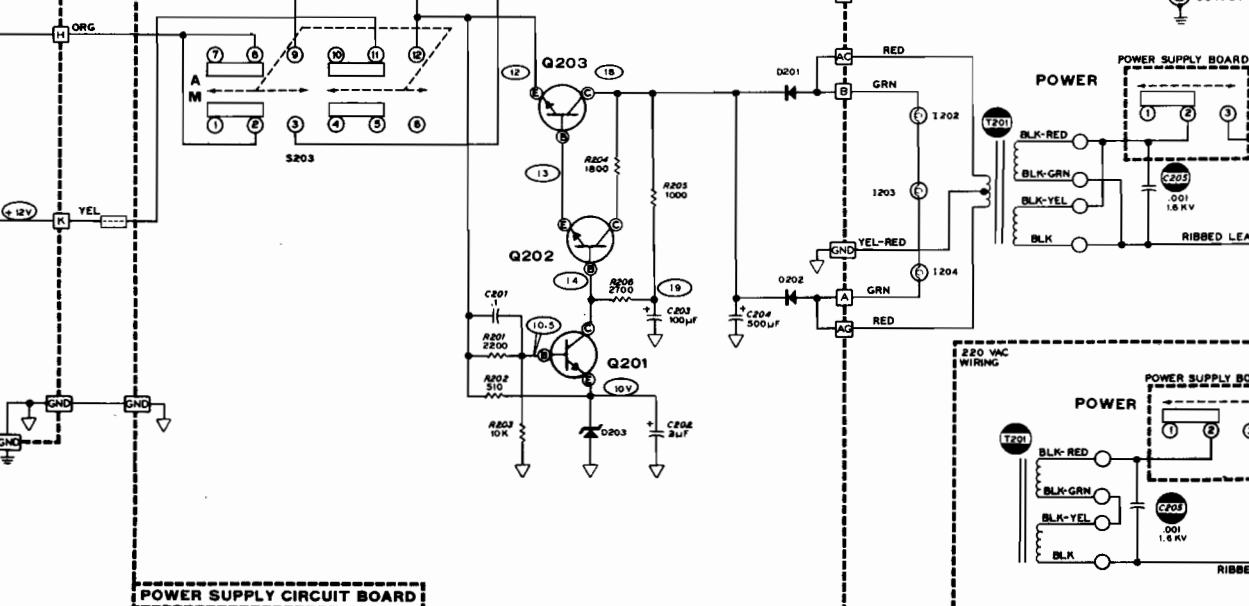
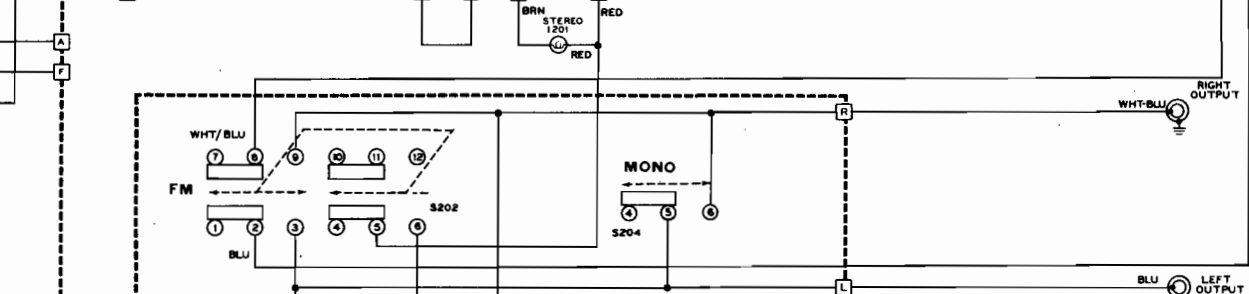
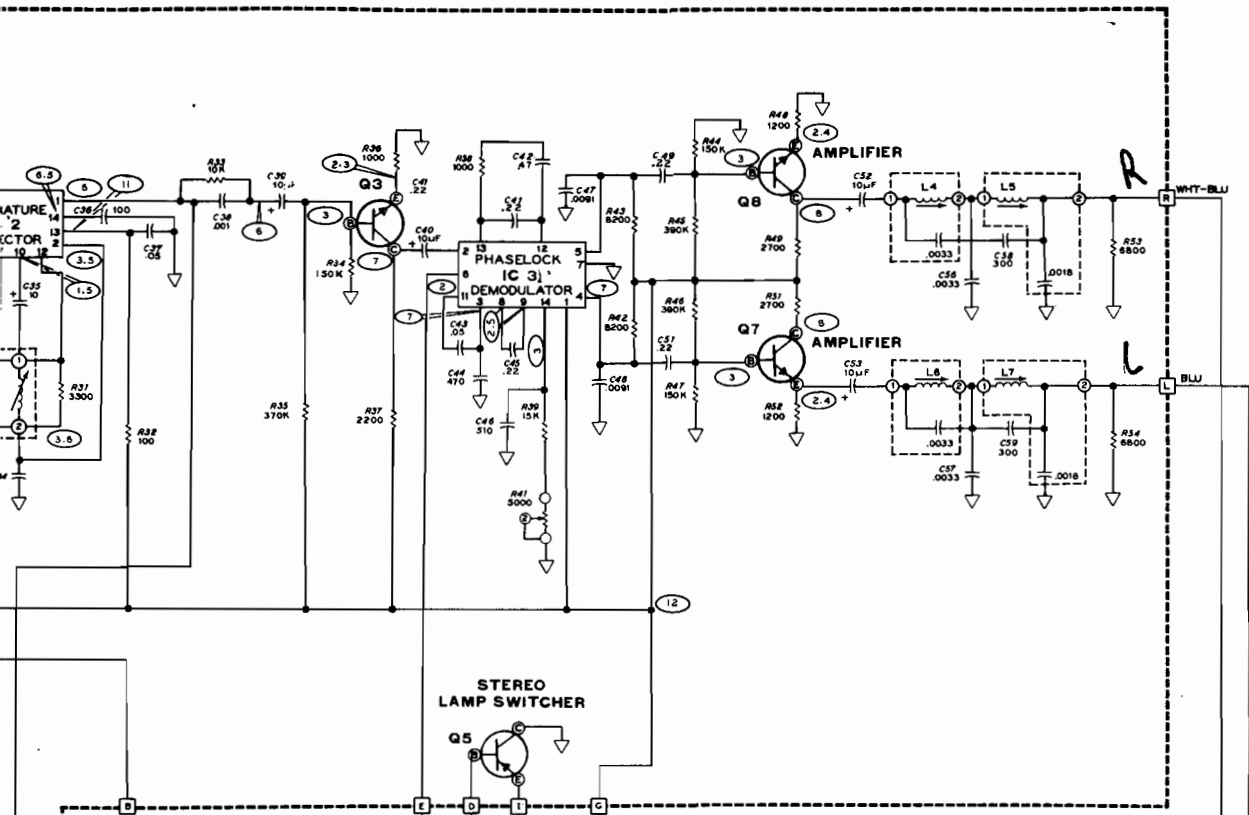

POWER SUPPLY CIRCUIT BOARD

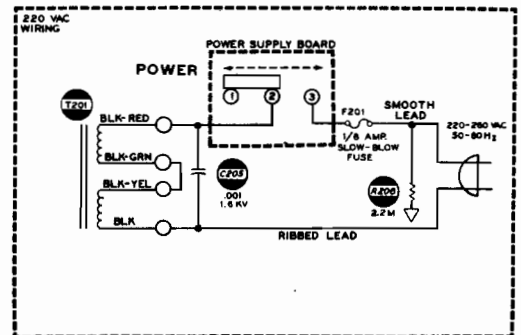

220 VAC WIRING

# CUSTOMER SERVICE

## REPLACEMENT PARTS

If you need a replacement part, please fill in the Parts Order Form that is furnished and mail it to the Heath Company. Or, if you write a letter, include the:

- Part number and description as shown in the Parts List.
- Model number and Series number from the blue and white label.
- Date of purchase.
- Nature of the defect.

Please do not return parts to the factory unless they are requested. Parts that are damaged through carelessness or misuse by the kit builder will not be replaced without cost, and will not be considered in warranty.

Parts are also available at the Heathkit Electronic Centers listed in your catalog. Be sure to provide the Heath part number. Bring in the original part when you request a warranty replacement from a Heathkit Electronic Center.

NOTE: Replacement parts are maintained specifically to repair Heathkit products. Parts sales for other reasons will be declined.

## TECHNICAL CONSULTATION

Need help with your Heathkit? . . . Self-Service? . . . Construction? . . . Operation? . . . Call or write for assistance. You'll find our Technical Consultants eager to help with just about any technical problem except "customizing" for unique applications.

The effectiveness of our consultation service depends on the information you furnish. Be sure to tell us:

- The Model number and Series number from the blue and white label.
- The date of purchase.
- An exact description of the difficulty.
- Everything you have done in attempting to correct the problem.

Also include switch positions, connections to other units, operating procedures, voltage readings, and any other information you think might be helpful.

Please do not send parts for testing, unless this is specifically requested by our Consultants.

Hints: Telephone traffic is lightest at midweek. . . please be sure your Manual and notes are on hand when you call.

Heathkit Electronic Center facilities are also available for telephone or "walk-in" personal assistance.

## REPAIR SERVICE

Service facilities are available, if they are needed, to repair your completed kit. (Kits that have been modified, soldered with paste flux or acid core solder, cannot be accepted for repair.)

If it is convenient, personally deliver your kit to a Heathkit Electronic Center. For warranty parts replacement, supply a copy of the invoice or sales slip.

If you prefer to ship your kit to the factory, attach a letter containing the following information directly to the unit:

- Your name and address.
- Date of purchase.
- Copies of all correspondence relevant to the service of the kit.
- A brief description of the difficulty.
- Authorization to return your kit C.O.D. for the service and shipping charges. (This will reduce the possibility of delay.)

Check the equipment to see that all screws and parts are secured. (Do not include any wooden cabinets or color television picture tubes, as these are easily damaged in shipment.) Place the equipment in a strong carton with at least THREE INCHES of resilient packing material (shredded paper, excelsior, etc.) on all sides. Use additional packing material where there are protrusions (control sticks, large knobs, etc.). If the unit weighs over 15 lbs., place this carton in another one with 3/4" of packing material between the two.

Seal the carton with reinforced gummed tape, tie it with a strong cord, and mark it "Fragile" on at least two sides. Remember, the carrier will not accept liability for shipping damage if the unit is insufficiently packed. Ship by prepaid express, United Parcel Service, or insured Parcel Post to:

Heath Company  
Service Department  
Benton Harbor, Michigan 49022



HEATH

**Schlumberger**

**HEATH COMPANY • BENTON HARBOR, MICHIGAN**  
***THE WORLD'S FINEST ELECTRONIC EQUIPMENT IN KIT FORM***

LITHO IN U.S.A.