

**Fender<sup>®</sup>**

THE SOUND THAT CREATES LEGENDS

'63 Fender Reverb

TYPE: PR 263

**Owner's Manual**

P/N 047980

# Introduction

Back in the days when blonde Showmans and white Jaguars dominated the nation's bandstands (and garages), there also existed a mysterious little box called the Fender Reverb. This was before the reverb we know and love today was "built-in" to Fender amplifiers. This inconspicuous device was responsible for the socking wet surf sound of the early 1960's. Nobody really knew exactly how it worked, but if you stuck it between your guitar and amp, turned all the knobs up about half way, you'd soon be hanging ten on a pipeline tidal wave.

Of all the effects devices produced over the past 40 years, the Fender Reverb has truly established itself as the "industry Standard" for the self-contained, tube driven spring reverb. The Fender Reverb has been used on thousands of recordings and countless live performances since the early 1960's, when the first version appeared on the music scene. Over the years, the Fender Reverb has proven to be incredibly versatile, being used for guitar, keyboards, vocals, accordion, electric violin, and an amazing array of other electrified instruments. Whatever the application, the Fender Reverb has always been able to produce "the right sound".

Your new '63 FENDER REVERB is a faithful reproduction of an original 1963 Fender Reverb (model 6G15 for historical or technical types). Every effort has been made to keep the circuit

exactly like the original. For improved reliability and manufacturing efficiency, a printed circuit board for the components is used in place of the original "Leo board" style phenolic parts panel used in the older Fender amplifiers for many years. The power and reverb transformers used in the '63 FENDER REVERB are built to the original specifications that are still in the Fender R&D department files. Due to the lack of availability, the original 6K6 power tube has been replaced with a modern 6V6. Some components used in this reissue product are different in size and shape from the earlier version, but the component values are identical.

If you compare a new '63 FENDER REVERB with an original model, the two units may sound slightly different. Remember the reverb pan and filter capacitors in the original are probably over 30 years old and their performance has changed over the years.

The built in quality of a Fender electronic product is the result of over four decades of dedication in the combined research and development skills of our engineers and musicians.

That is why we proudly say... **FENDER, *The Sound That Creates Legends.***

**WARNING: No user serviceable parts inside. Refer servicing to qualified personnel only.**

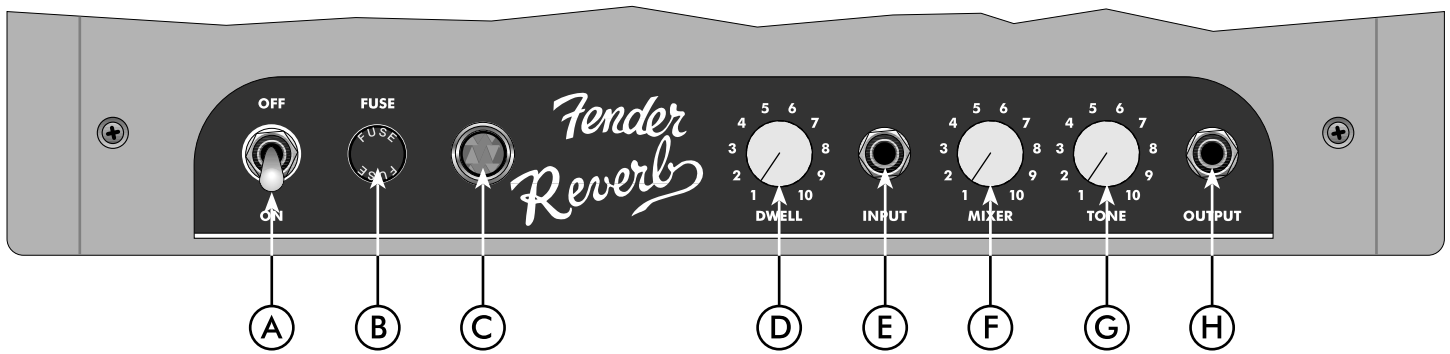

## NOTE: BEFORE ATTEMPTING TO OPERATE YOUR

**'63 FENDER REVERB**, turn the unit around and look inside the back. You will see a metal lever near the back and slightly left of center. This lever, when in the shipping or traveling position, is pushed toward the front of the cabinet and then to the right to lock. This lever pushes the inside of the pan against a soft foam pad and prevents the springs in the pan from being damaged due to excessive movement. To release the lever to the playing position, push the lever slightly forward and then to the left to unlock it. Let the lever come back as far as it can to release the pan.

### '63 Fender Reverb top panel functions

- A. **POWER SWITCH**-Turns the AC power ON and OFF. When the switch is in the OFF position, the unit is completely shut down.
- B. **FUSE**-The fuse is in the AC supply of the amplifier and will help to protect the amplifier and the operator in the event of an electrical fault. If a fuse blows, it should only be replaced with a fuse in accordance with the listing at the fuse holder. If an amplifier repeatedly blows fuses, it should be checked out by a qualified technician. **UNDER NO CIRCUMSTANCES** should a fuse of a different type, higher current rating, or a fuse bypass be used, as this could damage the equipment and present a serious safety hazard.
- C. **PILOT LIGHT**-This lamp is illuminated when the power is on.
- D. **DWELL**-Adjusts the amount of signal sent to the reverb pan. At low Dwell settings (two to four) the reverb sounds much like a guitar played into a large room. At high Dwell settings (above four) the reverb signal will start to sound more "springy" or "twangy".
- E. **INPUT**-A high impedance plug-in connection for instruments.
- F. **MIXER**-The reverb "wet" signal and the "dry" signal are mixed together at this control. The mixer adjusts what percentage of the signal sent to the output jack is from the reverb pan circuit compared to the dry signal. Higher settings equal more reverb.
- G. **TONE**-This control affects only the "wet" portion of the signal and acts much like the treble control on a guitar amplifier. Turning the Tone control up allows more high frequencies through from the reverb to the mixer control.
- H. **OUTPUT**-This is the output jack that is used to send the signal from the reverb unit to the amplifier.

### Using your '63 Fender Reverb

The '63 Fender Reverb is designed to go between a low level instrument (such as a guitar) and a high input impedance amplifier (such as any Fender tube amplifier or the high sensitivity input on any Fender solid-state amplifier). It should be used only with the clean channel of the amplifier as distorted reverb sounds very unnatural. If you want to use the '63 Fender Reverb with high gain or distortion, you may use either a distortion pedal inserted before the Reverb Unit or connect the Reverb Unit in the effects loop of the amplifier and use the high gain/distortion channel of the amplifier. However, since most of the sonic benefits of the '63 Fender Reverb result from the fact that the reverb signal is generated before the tone controls and preamp gain circuitry of the amplifier, we do not recommend using it in the effects loop.

## Troubleshooter's checklist

- Is the power cord properly plugged into an electrical outlet?
- Is there power at the outlet?
- Is the volume control on the instrument turned up?
- Is your instrument properly plugged into the Reverb Unit?
- Does the guitar and amplifier work properly without the Reverb Unit?  
(If so, then eliminate all other effects and try different guitar cords.)
- If, after checking all the above, the system is still not operating properly, consult your authorized Fender Service Dealer.

## '63 Fender Reverb specifications

		Brown W/Tan grille	Black W/Silver grille	Blonde w/Oxblood grille
Part Number:	120V Version:	21-7500	021-7501	021-7502
	230V Version:	21-7560	021-7561	021-7562
Input Impedance:		520k Ohms		
Nominal Gain:		Mixer fully CCW: 1 (With Mixer turned above "1" gain varies from pan to pan and with frequency)		
Power Requirement:	120V Version:	120 Volts AC, 60Hz, 45W Maximum		
	230V Version:	230 Volts AC, 50Hz, 45W Maximum		
Dimensions:	Height:	10 1/2' (26.7 cm)		
	Width:	18 7/8' (47.9 cm)		
	Depth:	7 1/2' (19.0 cm)		
	Weight:	13 Lbs. (5.9 kg)		

## '63 Fender Reverb Block Diagram

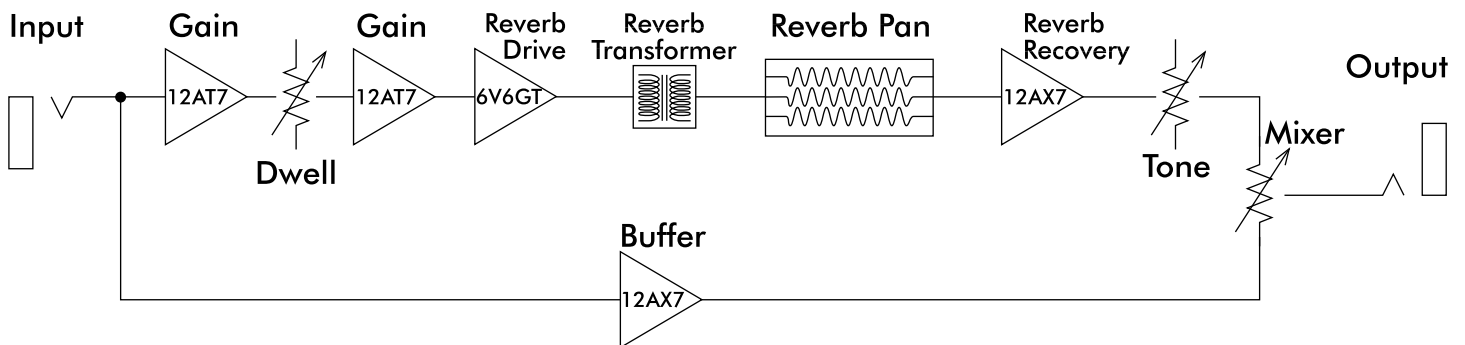

A PRODUCT OF:  
**FENDER MUSICAL INSTRUMENTS CORP.,**  
 CORONA, CA 91720