

Fig. 86. Small public-address amplifier, single-ended 6L6 output, 6 watts (RCA MI-12288B type SA-6A).

15. TYPICAL POWER AMPLIFIERS

In this section a number of tube and transistor amplifiers will be described briefly which employ the principles described in the foregoing sections. Other complete systems will be described in the sections on high-fidelity stereo systems.

15.1. Tube Power Amplifiers. Figure 86 shows the schematic of a small public-address amplifier, employing single-ended class A operation with a 6L6 output tube. This small amplifier has less than 5 per cent distortion at 6 watts output from 400 to 10,000 cycles. At 100 cycles the distortion is 8 per cent. The input transformer is balanced to ground for a 125- to 600-ohm microphone. Volume controls R_1 and R_2 are for microphone and crystal phono inputs, respectively. Negative feedback to the

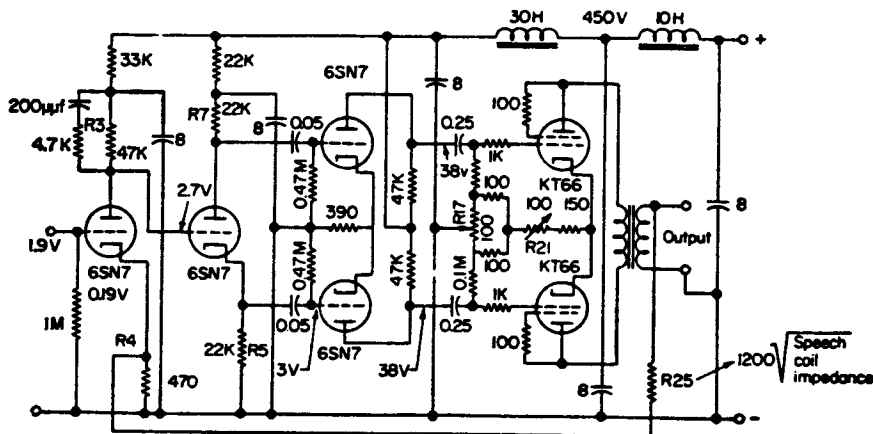

Fig. 87. Williamson high-fidelity amplifier schematic. [From Keith Henney (ed.), "Radio Engineering Handbook," 5th ed., McGraw-Hill Book Company, New York, 1959.]

cathode of the second 6J7 includes network R_{14} , R_8 , C_4 , R_9 , and R_{10} . The tone control R_{10} decreases the high-frequency response as desired.

Figure 87 shows the circuit of an early version of the well-known Williamson amplifier. This was one of the earliest of the truly high-fidelity amplifiers and still exemplifies good design principles. Some of the features of this design are negligible nonlinear distortion up to maximum rated output, linear response from 10 cps to 70 kc, negligible phase shift in the audible range, good transient response, and low output resistance. It is an all-triode power amplifier requiring 2 volts across 1 megohm for 15 watts output. The input 6SN7 is direct-coupled to the phase-splitter 6SN7 grid, whose plate and cathode, in turn, feed the output stage. From the low-impedance loudspeaker terminals 20 db is obtained and applied to the unbypassed cathode resistor R_4 of the input triode. Feedback resistor R_{21} depends on the output transformer connection used. For 1.7 ohms output R_{21} is 1,500 ohms, for 9 ohms it is 3,600 ohms, and for 16 ohms it is 4,800 ohms.

Figure 88 shows the frequency response, with and without feedback, also the phase shift from 1 to 1,000,000 cycles. This amplifier takes negative-feedback voltage around four stages, a severe test of design, and one of the outstanding features of this amplifier.

Preliminary adjustments are made by R_{21} to bring the total plate current of the KT66's to 125 ma, and with no signal input, by connecting a 10-volt d-c meter across

16. ELECTRON-TUBE STEREO AMPLIFIERS

In this section and the next a number of representative stereo systems, both tube and transistor, will be described. These incorporate many of the features which were described in the preceding sections of this chapter, and illustrate modern design techniques.

Stereo amplifiers are an extension of the earlier high-fidelity designs, with the utilization now of two complete channels to provide the stereo effect. By this means, the illusion of sound location is created; greater effectiveness is given to orchestral music by differentiation of the various sections, and an impression of motion can be created. This is accomplished by using two completely separate channels of communication, from microphone to loudspeaker, whether the transmission medium be radio waves or a phonograph recording. In the former either two separate transmissions may be used, e.g., TV and FM simultaneously, or the two channels may be used to provide two forms of modulation on the same carrier, e.g., amplitude and frequency or phase. In the recordings again two modes of reproduction are used, with two distinct groove modulations. The pickup must be specially designed for such reproduction, so that one output will be responsive only to one channel, the other to the second channel. Of course, mono phono operation may be obtained by simply using one channel, or both in parallel.

16.1. Sherwood Stereo Amplifier. The preamplifier portion of this system has already been described in considerable detail (see Sec. 10). This equipment has a rating of 40 watts music from each channel, 36 watts continuous, 72 watts peak on stereo; or on mono 80 watts music power, 72 watts continuous, 144 watts peak, at 1½ per cent intermodulation distortion (60 cps, 7 kc, 4:1).

Figure 101 provides an overall block diagram of the system. Each channel is identical with the other, and consists of input switching to accommodate phono, tape, tuner, or auxiliary inputs; preamplifiers and frequency equalization circuits for the phono and tape inputs; a function selector which interchanges the speakers, allows reproduction of mono programs on both speakers, and permits use of the stereo pickup on monaural recordings; further amplification, with associated filters and tone controls; loudness and balancing controls, driver stages, and push-pull output stages.

Figure 102 shows the schematic of this amplifier, showing both channels. Figure 102a is the same previously shown as Fig. 43 and is repeated here for convenience. Figure 102b shows the output portion. The input switch on the left selects any of the five inputs and connects them to the appropriate amplifier. The phono and tape inputs go to the preamplifier V_1 , whereas the auxiliary and tuner inputs are routed to amplifier V_2 . The RIAA or NAB frequency compensations are accomplished by means of feedback around tube V_2 through capacitors C_3 , C_4 , C_5 and resistors R_9 and R_{10} . The gain control varies the signal applied to amplifier V_2 , through the scratch filter, which may be cut in or out as desired. The tone controls, inserted between tubes V_2 and V_4 , vary the treble or bass response independently. The treble control

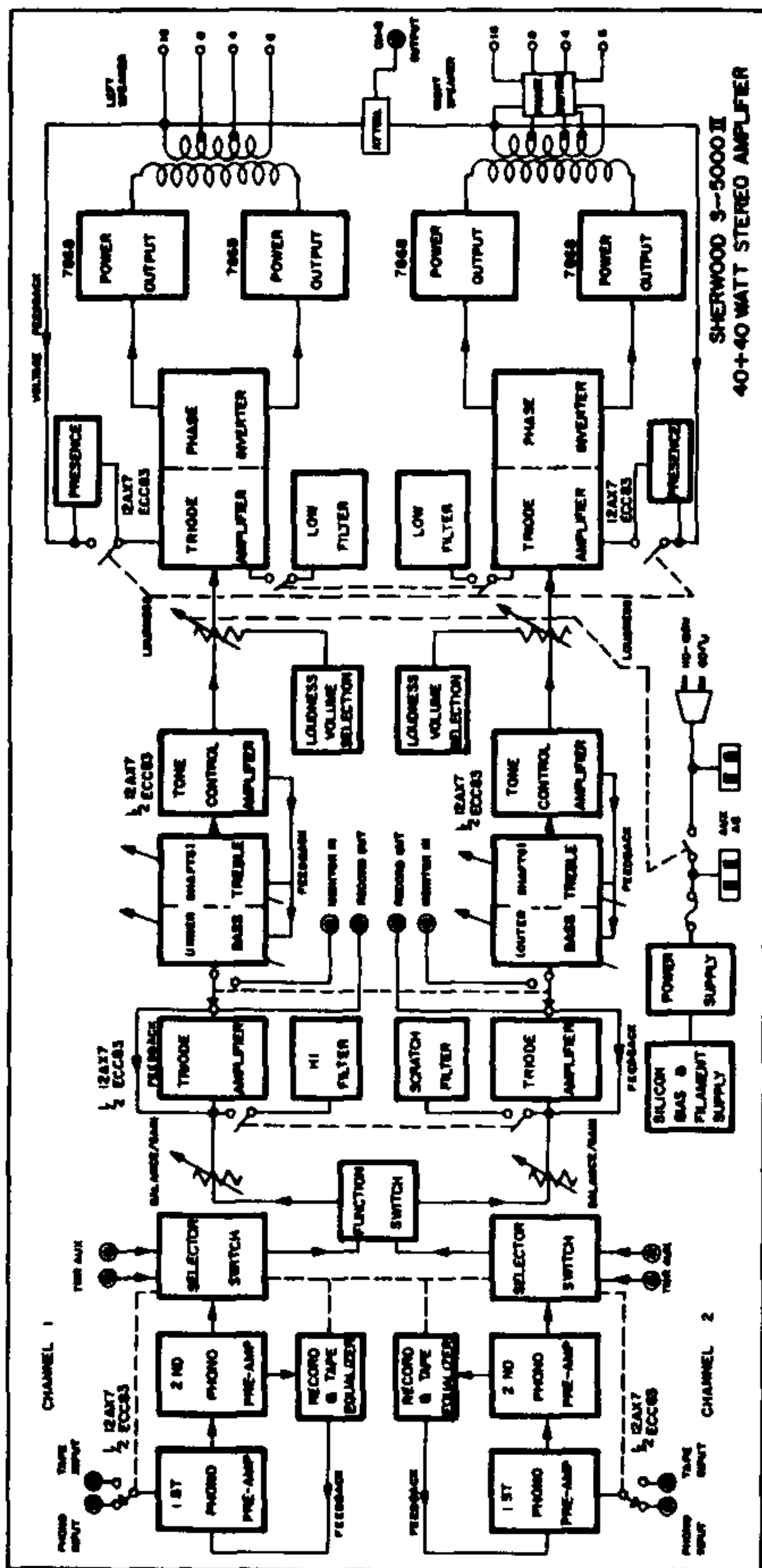

Fig. 101. Block diagram of Sherwood stereo amplifier.

functions either by adding to the high-frequency response when in its extreme left-hand position (on the schematic) by connecting the 180-pf capacitor between the plate of output of V_3 and the grid of V_4 , or by reducing the response by using this capacitor to produce degenerative coupling from the plate of V_4 , in the other extreme position. The bass control similarly varies the coupling to the preceding tube or the feedback from the plate, by varying the input from one 3,300-pf capacitor to the other.

It will be noted that there are separate loudness and gain controls. The loudness control has associated with it an RC network which varies the frequency response as the loudness is varied, thus compensating for the variation in frequency response of the human ear as a function of intensity. In operation the gain control is set at that position which produces relatively loud intensity with the loudness control on full; then the volume is thereafter adjusted with the latter control.

A rumble filter is available, following the loudness control, by means of which rumble due to turntable eccentricity or other causes may be reduced. The driver stages act as phase inverters, to provide the push-pull output for the output tubes, and the balance controls are provided to enable setting the two halves of the push-pull pair to equal outputs. Feedback is provided from the 16-ohm output terminals to the cathode of V_3 .

Figure 103 indicates the harmonic and intermodulation distortion vs. power output, and Fig. 104 shows the frequency response and distortion as a function of frequency at 1 watt and 36 watts output. The effects of loudness and tone controls on frequency response have been shown in the section on preamplifiers (see Figs. 44 and 45).

Figure 105 shows the overall acoustic response using this amplifier and a three-speaker arrangement. The speakers are a 12-in. high-compliance woofer, an 8-in. cone midrange speaker with sealed fiberglass fill backplate, and one 3½-in. specially designed ring-radiator supertweeter, also with sealed fiberglass-fill backplate. Cross-over points are 600 and 3,500 cps with 12 db/octave attenuation.

The performance specifications of this system are:

Power output: Stereo, each channel 40 watts music power (36 watts continuous, 72 watts peak). Mono, 80 watts music power (72 watts continuous, 144 watts peak), at 1½ per cent IM distortion (60 cycles, 7 kc, 4:1).

Outputs: 16-, 8-, and 4-ohm left and right speakers; 2 recording, third channel.

Inverse feedback: 16 db.

Damping factor: 5:1.

Frequency response: (36 watts) 20 cps to 20 kc $\pm \frac{1}{2}$ db.

Tone-control response: Flat setting, 20 cps to 20 kc, $\pm \frac{1}{2}$ db.

Tone-control range: 15 kc, 17-db boost or cut. 40 cps, 16-db boost, 19-db cut.

Rumble filter: 27 cps, 17-db rejection; 70 cps less than 1 db down.

Sensitivity: Radio 0.25 volt, tape 1.4 mv, phono 1.2 mv; all inputs are adjustable with level control.

Maximum input capability: Phono, 200 mv for less than 1 per cent distortion. Radio, adjustable with level control.

Maximum hum and noise: Volume control minimum 100 db (weighted) below rated output. Radio input (controls maximum), 90 db (weighted) below rated output. Phono input (controls flat), 60 db below rated output, 72 db below 10 mv (equivalent to $\frac{1}{2}$ μ v referred to input grid).

Interchannel crosstalk: Less than -50 db at 1 kc.

Power consumption: 110 to 120 volts, 60 cps, 150 watts, 1.3 amp.

Tube complement: four 7868, six 12AX7/ECC83, four silicon rectifiers.

16.2. General Electric Stereo Amplifier. This amplifier is designed to deliver 50 watts music power per channel, and illustrates some of the problems faced by designers in their attempts to balance performance with cost.

The output tubes are the GE type 7355's, used in class AB₁. With 400 volts on the plates, 320 volts on the screens, and a -36-volt bias, two of these tubes can be driven to 50 watts of continuous output power with less than 5 per cent harmonic distortion. The plate-to-plate reflected load is 4,000 ohms. Peak-to-peak drive voltage of 72 volts is required.

Since the output stage operates in class AB₁, there is considerable variation of plate

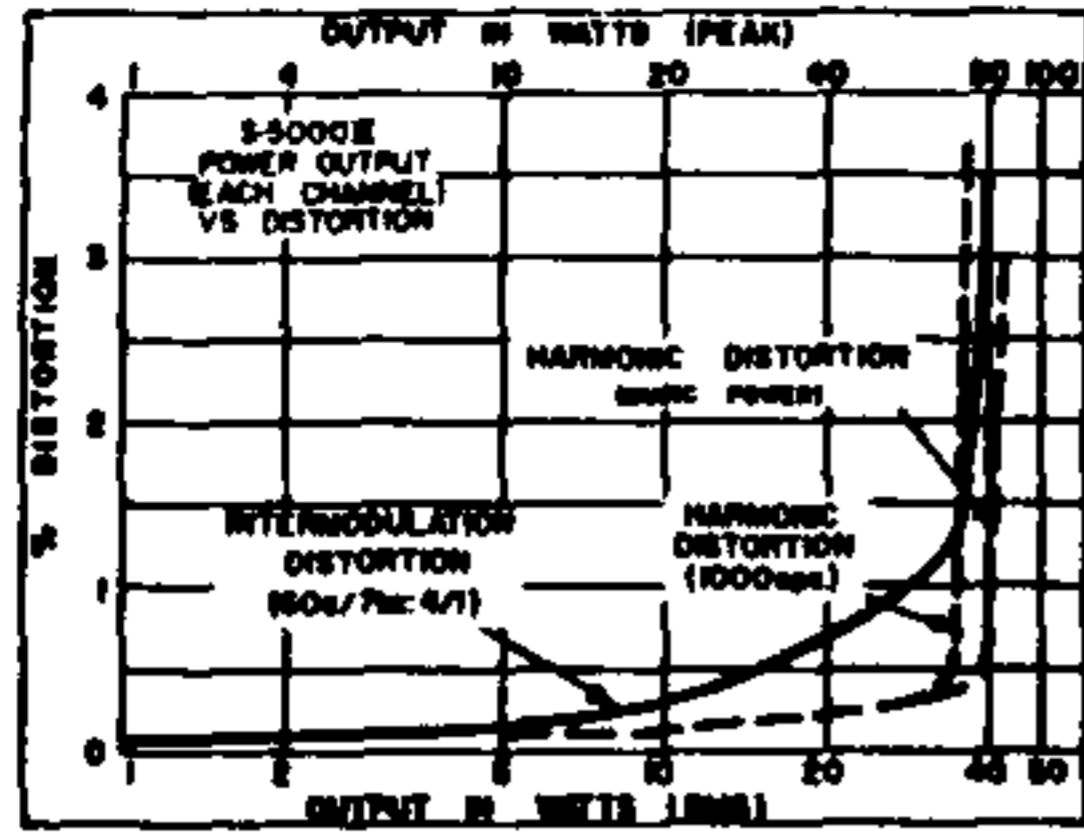

Fig. 103. Distortion vs. power output.

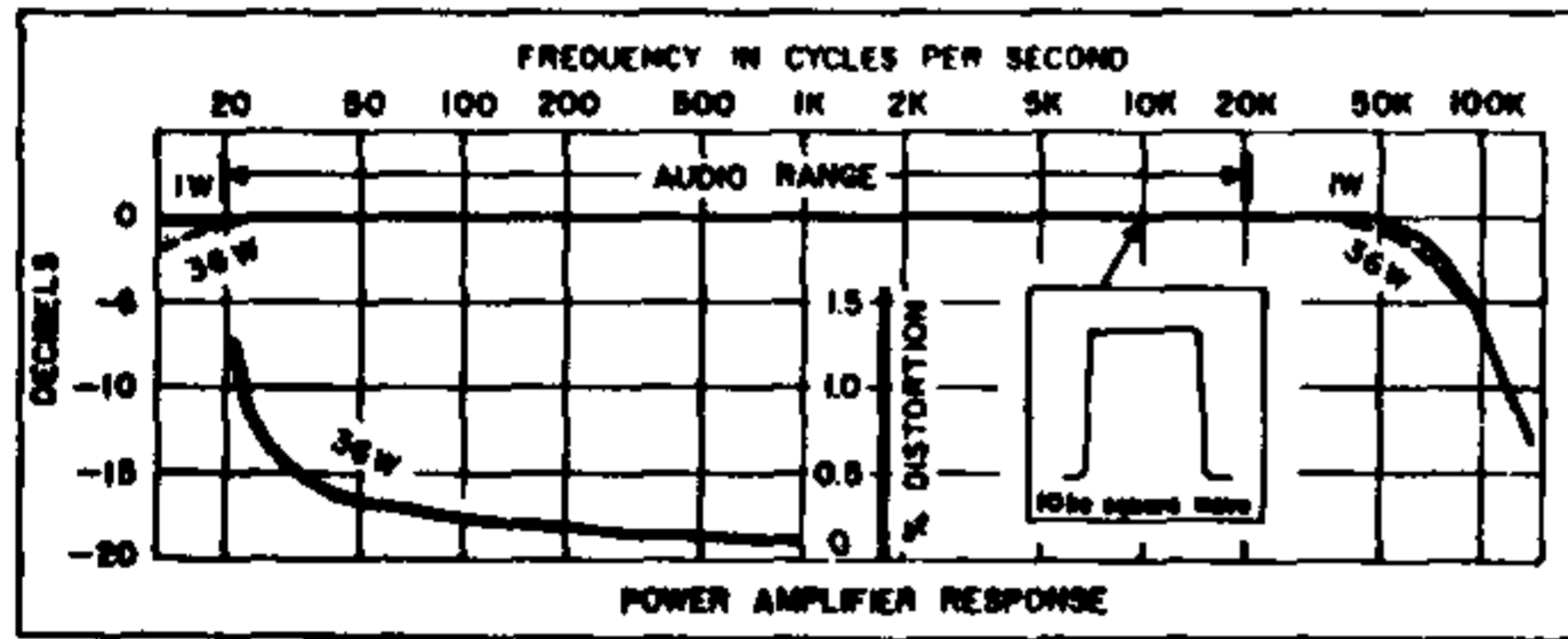

Fig. 104. Frequency response.

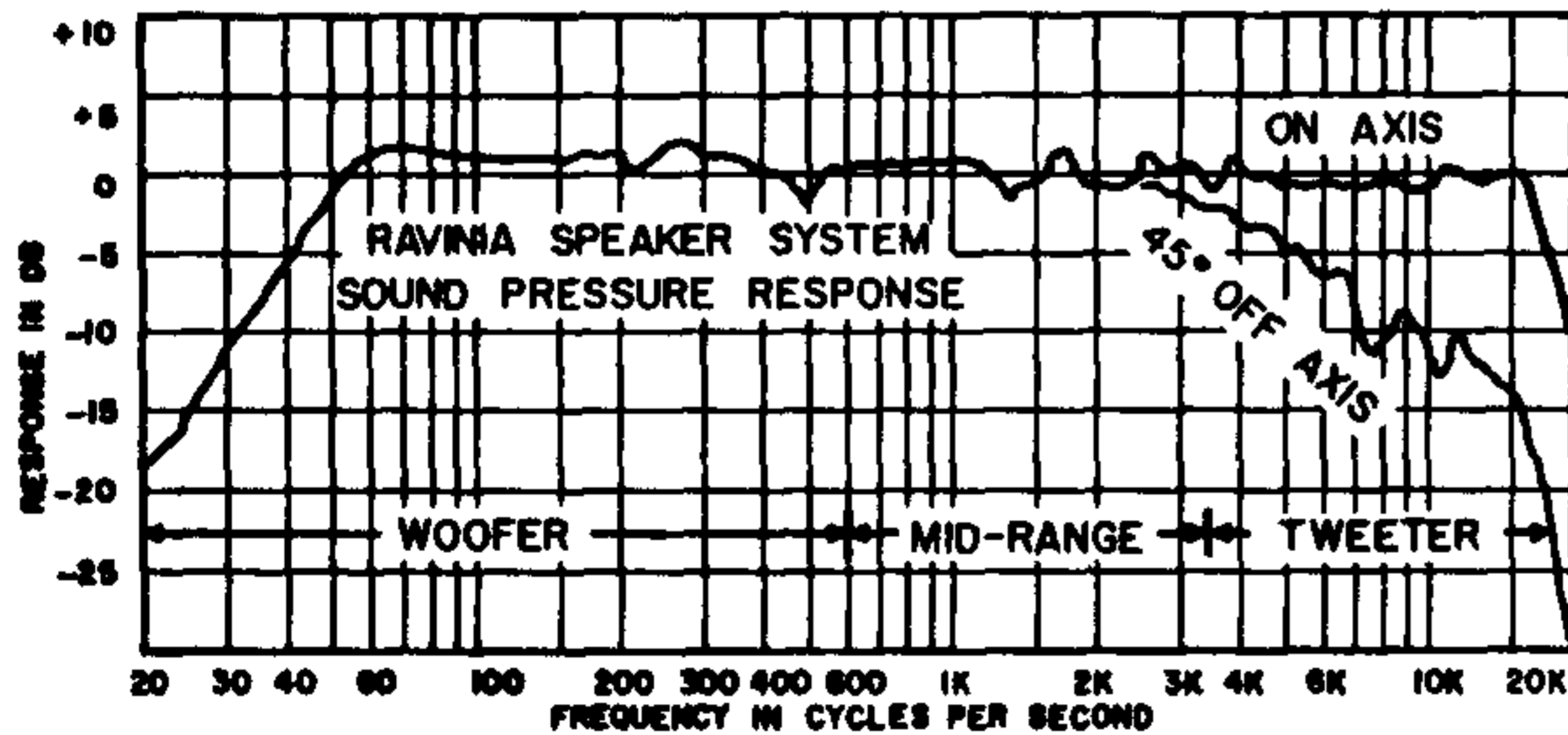

Fig. 105. Sound pressure response, Sherwood stereo system.

and screen current with input signal and hence output power. This poses severe design problems in supplying adequately regulated voltages for the plates and screens. At full continuous output from both channels, the power supply would have to supply 400 ma of plate current and 60 ma of screen current for the output stages. This is illustrated in Fig. 106, which shows this variation for two tubes. These values must be doubled if both channels are working under the same conditions.

If this rating of continuous power output were to be met it would require a very well-regulated power supply for the plate and screen voltages, with the screen requiring a separate supply. The transformer windings would have to be low in resistance and the rectifier diodes would have to have low forward voltage drops. These requirements would add considerably to the overall cost of the system. A study was therefore made of the actual requirements of the system, and it was concluded that continuous ratings of the above values were not actually needed for satisfactory reproduction of music, as long as some means of energy storage was incorporated, such that full power could be maintained for the actual duration of music peaks. This was accomplished by means of heavy storage capacitance on the screens (100 μ f), which produces discharge time constants ranging from 4 sec at zero signal to 0.5 sec at 50 watts output.

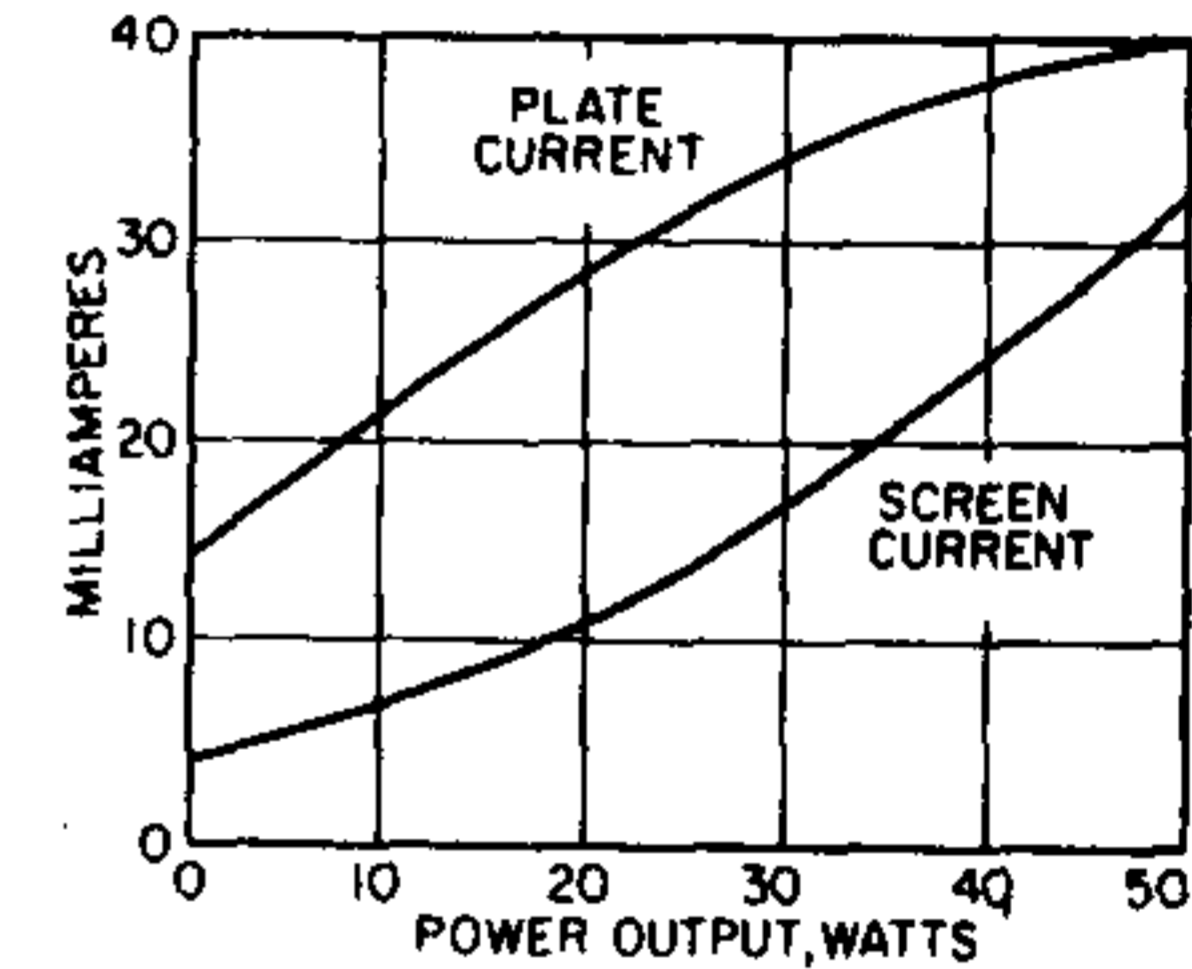

Fig. 106. Plate and screen currents (two tubes) vs. music power output.

This technique has been found entirely satisfactory, as evidenced by listening tests, where it was compared with arrangements with constant voltage supplies.

Figure 107 shows the circuit of the preamplifier portion of this system. The input selector switches from the dual stereo phono cartridge to the stereo FM tuner input. The loudness controls are compensated so that the frequency response is varied with loudness setting, as described previously in the section on preamplifiers. The treble and bass tone controls operate in similar manner to those of the Sherwood amplifier, although negative feedback is not employed here. A scratch filter can also be inserted to improve the reproduction from older records.

Figure 108 shows the schematic of the output portion of the amplifier, including the driver-phase inverters and push-pull output stages. The power supply for this portion of the amplifier is also shown, and the 100- μ f capacitor on the screen supply may be noted. An RC network is connected between the two plates. This was used to avoid an oscillation due to the output transformer primary leakage inductance. Reducing this leakage reactance permits removal of this network and also improves the frequency response. Feedback of 14 db is employed in this design, from the output transformer secondary to the cathode of the driver tube.

Figure 109 shows the output of this amplifier at 5 per cent distortion, as a function of frequency, with the oscillation-suppression network connected, and Fig. 110 without it but with a transformer having a lower leakage inductance. Figure 111 shows the frequency response of the system, including the effects of the tone controls. Figure 112 shows distortion vs. power output.

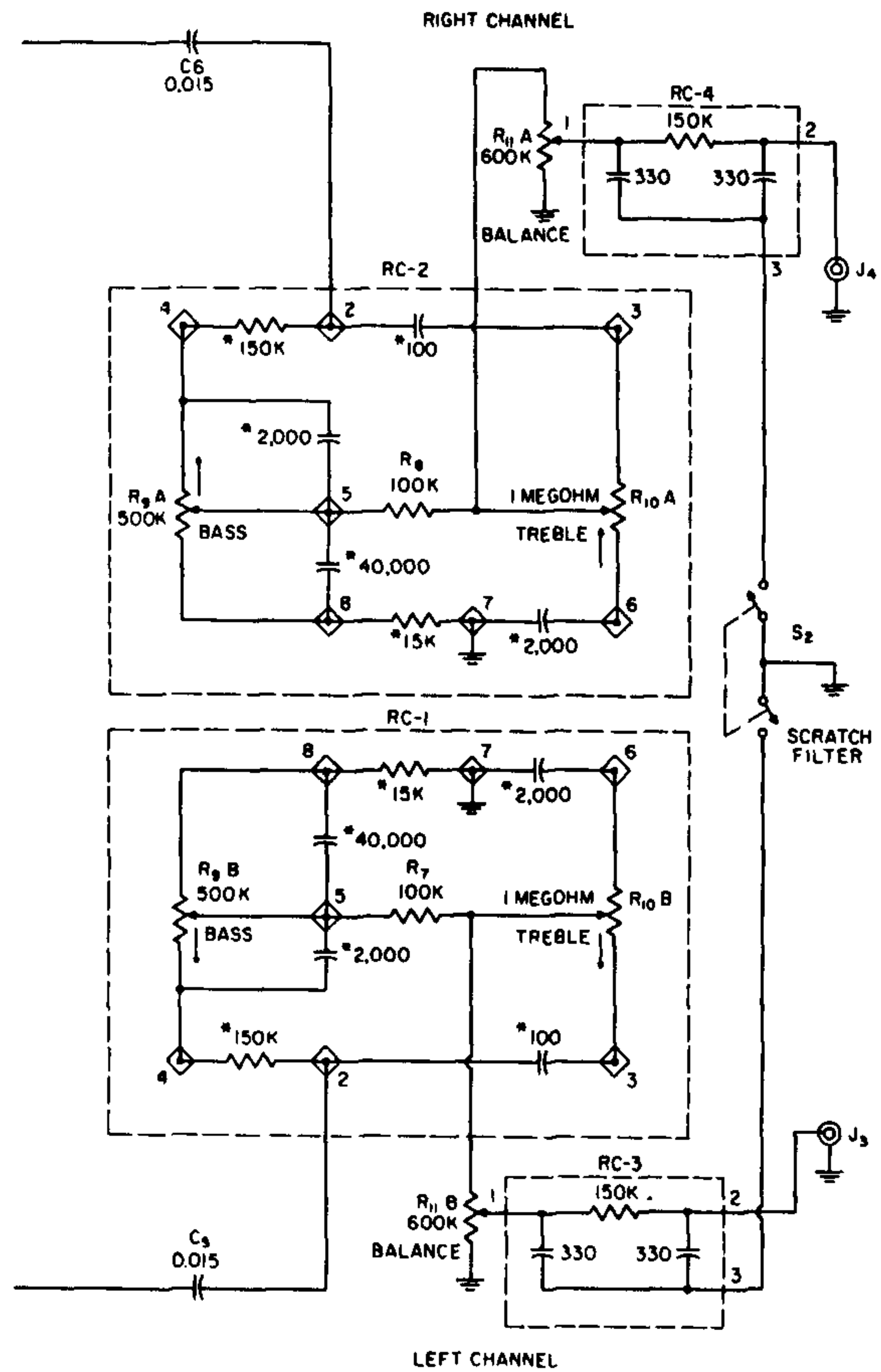
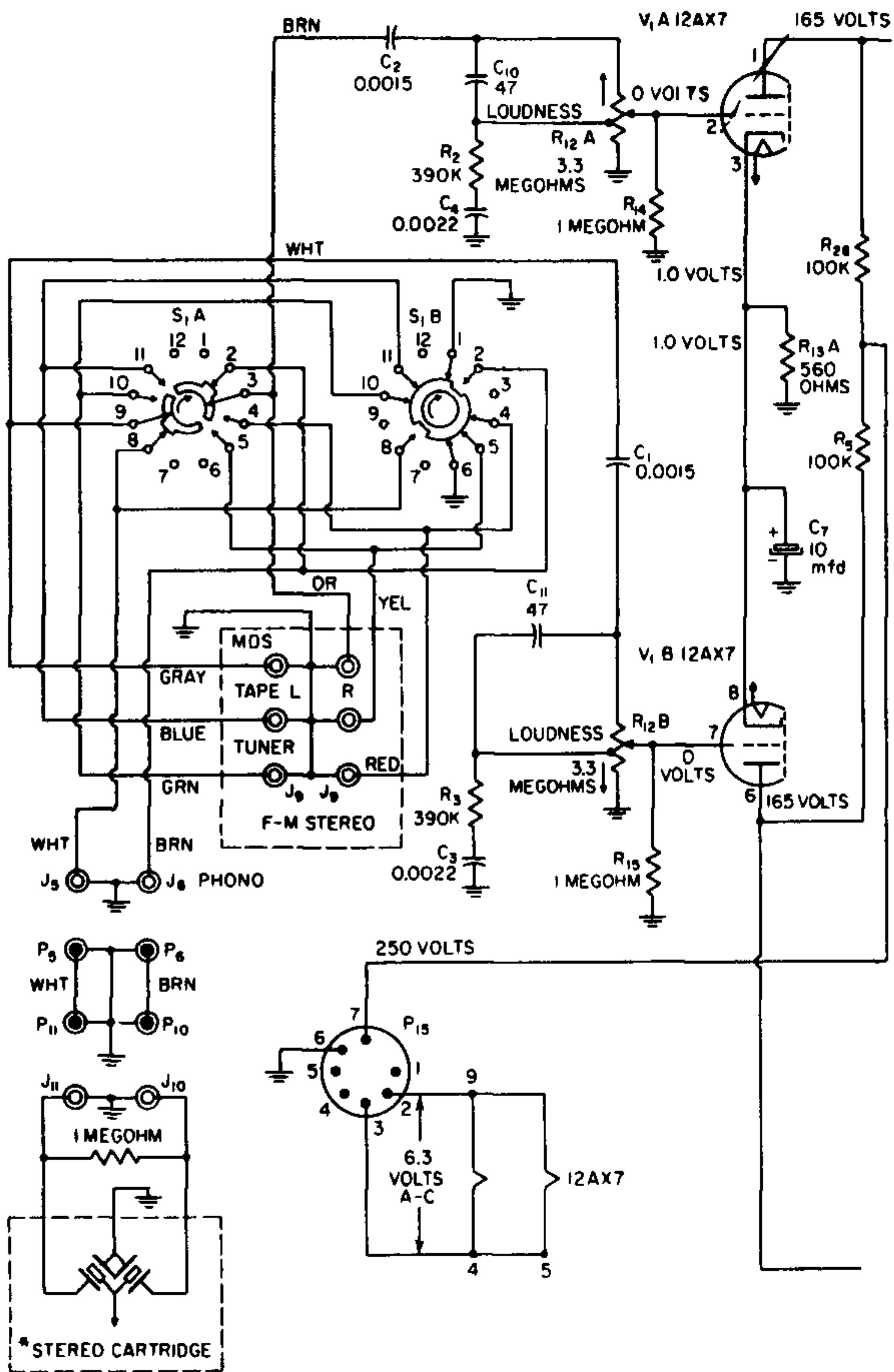

FIG. 107. Schematic of preamplifier for 100-watt stereo amplifier. *Ceramic-type output

0.4 volt from average recording level.

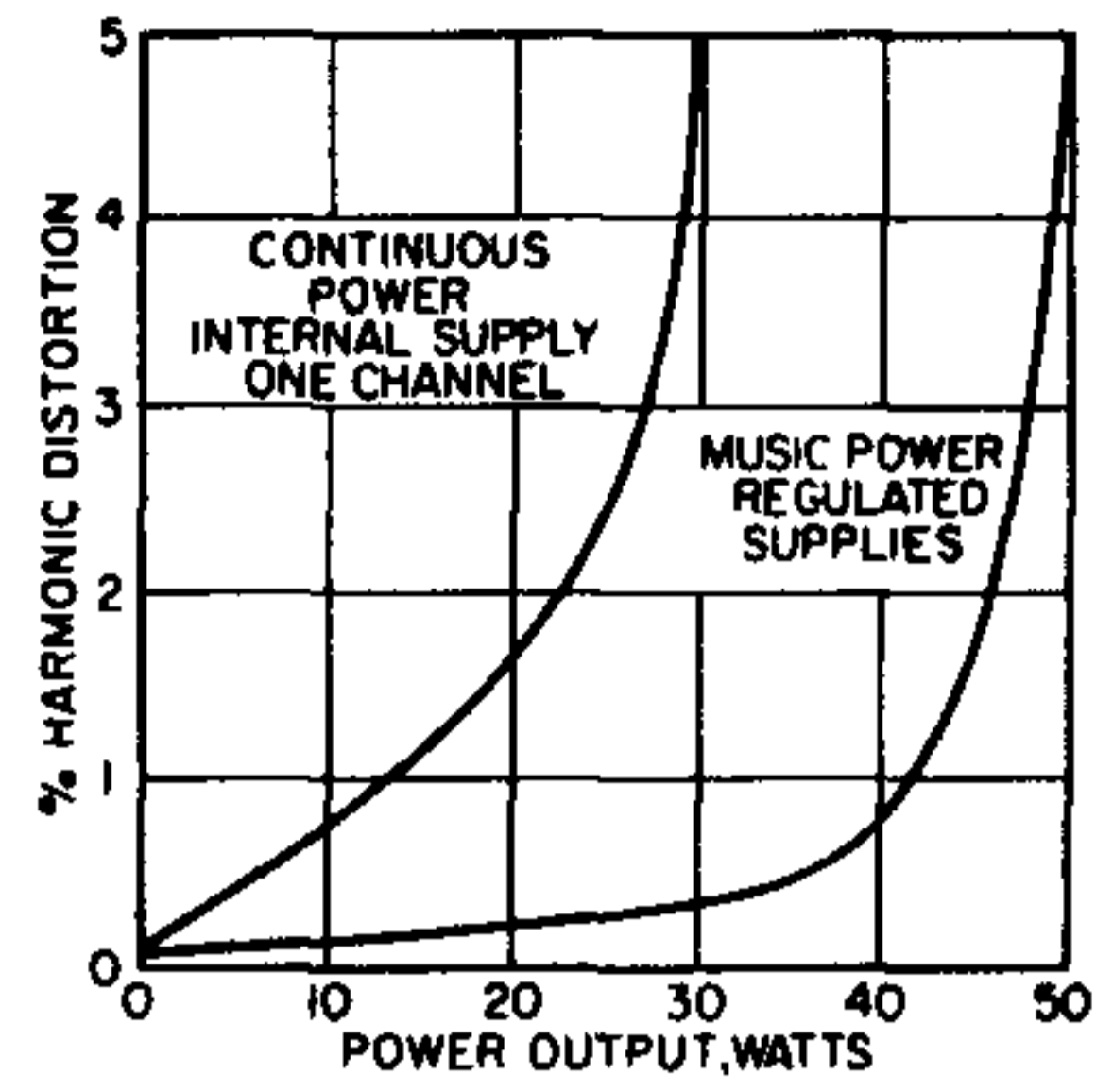

FIG. 112. Distortion vs. power output, 100-watt stereo amplifier.