

HELLO

OPERATING INSTRUCTIONS
for

DYNAMIC
MUTUAL CONDUCTANCE
TUBE TESTER

Model 532

Hickok
Dynamic Mutual
Conductance Tester

Reads Directly in
MICROMHOS

Manufactured by

THE HICKOK ELECTRICAL INSTRUMENT COMPANY

10514 DUPONT AVENUE

CLEVELAND 8 OHIO



Reworked by
PAØPGA

This manual was downloaded from BAMA's
boatanchor site <http://bama.sbc.edu>



OPERATING INSTRUCTIONS
FOR
DYNAMIC MUTUAL CONDUCTANCE TUBE TESTER
MODEL 532

THE HICKOK ELECTRICAL INSTRUMENT COMPANY

10514 Dupont Ave.
Cleveland 8, Ohio



HICKOK MODEL 532 DYNAMIC MUTUAL CONDUCTANCE TUBE TESTER

PACKER'S CHECK

MODEL 532 TUBE TESTER

SERIAL NUMBER _____
INSTRUCTION BOOK, MODEL 532 _____
DATE _____
SIGNED _____

PACKER

NOTE

READ INSTRUCTIONS CAREFULLY BEFORE ATTEMPTING TO OPERATE THIS TUBE TESTER.

SECTION I

DESCRIPTION

1. PURPOSE.

a. The Model 532 Tube Tester is used to test and measure mutual conductance values of vacuum tubes used in radio receivers and transmitting tubes delivering less than 25 watts of power.

b. The Model 532 Tube Tester is fundamentally of the Dynamic Mutual Conductance type designed to provide either REPLACE - GOOD readings or mutual conductance values in micromhos. Provision is made for locating shorts and leakages between tube elements. A sensitive noise test is also provided.

c. Mutual conductance values in three ranges can be measured: 0-3000, 0-6000, and 0-15,000 micromhos. Included in this tube tester is an ENGLISH reading range. By means of this range, a good tube will cause the pointer of the indicating meter to rest in the GREEN (GOOD) sector of the meter scale. A bad tube will read in the RED (REPLACE) or doubtful (?) sector.

d. Gas Test: Provision is made to test amplifying vacuum tubes for gas content. Gassy tubes will ruin the automatic volume control or intermediate stages of a radio receiver.

2. TUBE COMPLEMENT. -- The Model 532 requires one #83 mercury vapor rectifier and one 5Y3GT vacuum rectifier tube for

its operation. These tubes are supplied and installed in the tube tester. The fuse lamp is a standard #81 auto lamp. The neon lamp is a G.E. 1/4 watt, 105-125 volts, candelabra base.

SECTION II

FUNCTIONS OF THE COMPONENTS

3. LINE VOLTAGE ADJUSTMENT. -- The Model 532 Tube Tester operates from A.C. power lines of 105 to 125 volts, 60 cycles. After the power is turned on, press the push switch P7 (LINE ADJ.) which will cause the indicating meter pointer to move up scale. The button P7 is held down and the knob, LINE ADJUST, is turned until the meter pointer rests exactly over the mark, LINE TEST, at 1500 on the meter scale. This establishes standard voltages to the tube elements. This adjustment is made with the control settings properly arranged for the tube being tested and with the tube in its test socket.

4. SELECTORS. -- The row of selector dials across the center of the control panel is for the purpose of conducting proper voltages to the tube's base pins. The operation of setting these dials is similar to DIALING A TELEPHONE NUMBER. On the roll data chart, below the word SELECTORS, appear the dialing numbers. These dialing numbers consist of two letters and five figures. Example: JR-6237-5. Starting at the left, the first dial is turned until the letter "J" appears through the window. The second dial is turned until "R" appears. The

1



Reworked by
PAØPGA

This manual was downloaded from BAMA's
boatanchor site <http://bama.sbc.edu>



third dial indicates 6; the fourth, 2; the fifth, 3; the sixth, 7 and the seventh, 5. The lettered dials control the filament or heater connections. The numbered dials control the GRID, PLATE, SCREEN, CATHODE and SUPPRESSOR in that order. In the example given above the heater terminals are connected to pins 8 and 1. The GRID is connected to pin 6; PLATE, to pin 2; SCREEN, to pin 3; CATHODE, to pin 7 and SUPPRESSOR, to pin 5.

These dial switches are electrically interlocked in such a way that it is impossible to connect two different voltage elements to the same pin. Thus accidental shorts are avoided.

The dialing system is designed so that a minimum of dial setting is required. For example, the heater setting is practically always JR so that these two dials seldom need resetting. It will also be noticed that when testing duo-diode triode tubes the amount of dialing has been reduced to a minimum.

5. **SHORT TEST.**--Turning the SHORTS switch successively through the positions 1-2-3-4-5 connects the various pairs of elements in turn across the test voltage. Tubes having shorted elements will complete the circuit and cause the neon SHORT lamp to glow. Tubes may be tested for shorts, either hot or cold.

A short is indicated by a steady glow of the neon lamp in certain positions of the SHORTS switch. A momentary flash of the lamp as the switch is turned from one position to another should be disregarded. This flashing is caused by the charging of a capacitor in the test circuit. A shorted tube should be discarded without further test.

6. **LOCATING SHORTED ELEMENTS.**-- In the following table (X) under any SHORT switch position indicates that the neon lamp glows in that position.

KIND OF SHORT	1	2	3	4	5
FIL -- CATHODE			X		
FIL -- GRID	X	X			X
FIL -- PLATE	X	X		X	X
FIL -- SCREEN	X		X	X	X
FIL -- SUP		X			
GRID -- CATHODE	X	X	X		X
GRID -- PLATE				X	
GRID -- SCREEN		X	X	X	
GRID -- SUP	X				X
PLATE --- SCREEN		X	X		
PLATE -- SUP	X			X	X
SCREEN -- SUP	X	X	X	X	X

2

7. **NOISE TEST.**--The short test circuit is also used in making noise tests on vacuum tubes. Connections are made from the noise test jacks to the antenna and ground posts of any radio receiver. The tube under test is tapped with the finger as the SHORTS switch is turned through positions 1-2-3-4-5.

Intermittent disturbances which are too brief to register on the neon lamp will be reproduced by the loud speaker as static.

8. **GAS TEST.**--The push switch P5 (Gas 1) and P6 (Gas 2) are used to test an amplifier tube for gas content.

a. The MICROMHO switch is set on 3000.

b. The push switch P5 is pressed and held down while the BIAS dial is turned to cause the pointer of the indicating meter to read 100 micromhos.

c. P5 is held down and P6 is pressed.

d. If the tube contains gas the meter pointer will move up the scale. If the pointer movement is not more than one small division of the scale the gas content is satisfactory.

NOTE

With some tubes, such as the type 45, the micromho reading cannot be brought down to 100 by turning the BIAS dial. In such a case turn the BIAS dial to 100 and test for gas.

Some tubes develop gas after being heated for a period of time. If a tube is suspected, allow it to heat for a few minutes.

9. **DYNAMIC MUTUAL CONDUCTANCE.**--The push switch P4 is used when testing for mutual conductance value. The indicating meter will register the tube's value in MICROMHOS in three ranges: 0-3000, 0-6000 and 0-15,000. The range to be used is controlled by the MICROMHO switch. When measuring micromhos in any of the three ranges listed above, no setting of the ENGLISH dial is required.

The fourth range, ENGLISH, on the MICROMHO switch is used when it is desired to test the tube in terms of GOOD-



SOCKET NUMBERING BOTTOM VIEWS

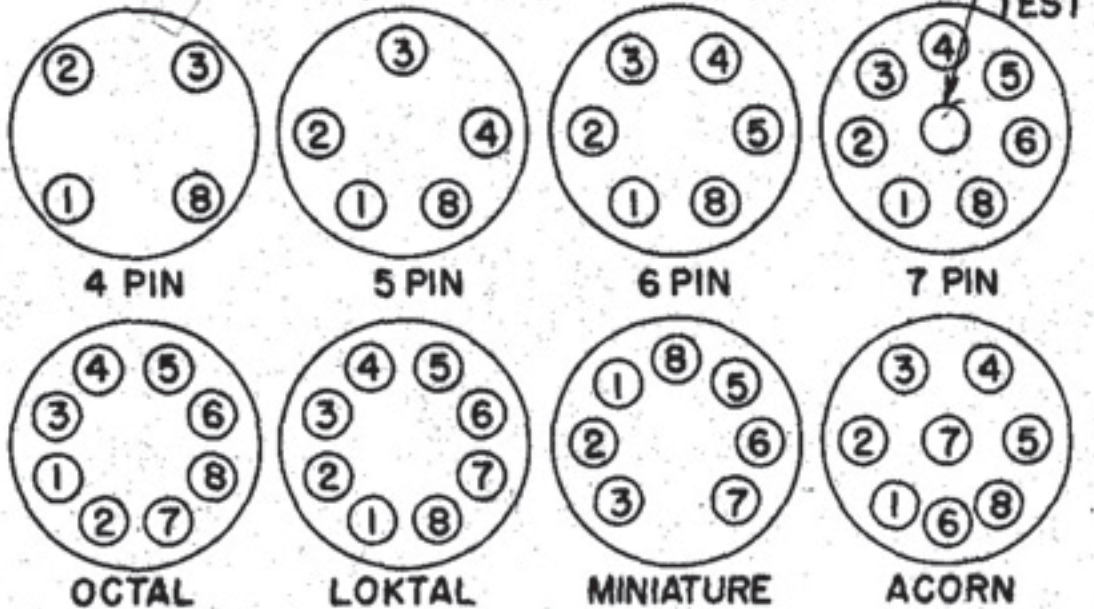

REPLACE. In this case the ENGLISH dial must be set in accordance with the figures given on the data chart under the heading, ENG. When using the ENGLISH range, good tubes will cause the meter pointer to read in the GOOD sector. Worn out tubes will read in the REPLACE sector. Those tubes which read in the sector marked (?) have some useful life but should be replaced soon. The ENGLISH reading scale is also based on Dynamic Mutual Conductance. It is not an emission test.

The Micromho values printed on the data roll are average values. A small variation above or below these average values is to be expected even with new tubes.

The ENGLISH scale is designed to make tubes read at the left edge of the GREEN (GOOD) sector when 20% below average for amplifier tubes and 35% below average for power tubes.

10. RECTIFIER TEST. -- The push switches P1, P2 and P3 are used to test various types of rectifier elements.

a. The push switch P1 is used when testing detector diodes. It applies a low voltage which will not injure the

delicate cathode. Good diodes will cause the meter pointer to read above the mark, DIODES OK.

b. Push switch P2 is used when testing cold cathode rectifiers such as the 0Z4. This applies a voltage sufficiently high to ionize the tube and start conduction. Good tubes will read in the GREEN (GOOD) sector of the meter.

c. Push switch P3 is used when testing ordinary rectifier tubes such as the 5Y3. This switch applies a medium voltage which is best adapted to reveal defects in this type of tube. Good tubes will read in the GREEN (GOOD) sector of the meter.

NOTE

On the data chart a star (*) following P1, P2, and P3 indicates that the MICROMHO switch is to be set on ENGLISH.

11. SOCKET NUMBERING. -- In order to reduce dialing to a minimum, the sockets in the Model 532 Tube Tester are numbered as shown in Plate 1, which shows



the bottom views. The numerical values of the lettered dials are as follows:

0	----	A	----	P
1	----	B	----	R
2	----	C	----	S
3	----	D	----	T
4	----	E	----	U
5	----	F	----	V
6	----	G	----	W
7	----	H	----	X
8	----	J	----	Y
9	----	K	----	Z

The letter "I" was omitted because of its resemblance to the figure "1". The letter "Q" was omitted because of its resemblance to the figure "0".

12. METER REVERSE. -- Directly below the indicating meter is a switch marked REVERSE-NORMAL. With certain tubes such as the 117N7, the meter, when set on NORMAL, will deflect backwards (to the left) when push switch P3 is pressed for rectifier test. In such a case, turn the meter switch to REVERSE which will cause the pointer to move up the scale. After this test has been made, return the switch to NORMAL.

13. TOP CAPS. -- There are two jacks in the upper center of the control panel marked GRID and PLATE. These are used when making connection to the top cap of the tube being tested. On the data chart in the NOTATIONS column opposite tube types having top caps, is the notation CAP=G or CAP=P. G means that the top cap is connected to the GRID and P, to the PLATE jack.

NOTE

The center of the seven pin socket is used to check pilot lamps. Voltages up to 12.6 are available for pilot lamp test. These voltages are controlled by the filament switch. No further switch setting is necessary.

14. SPECIAL NOTES. -- Power line voltage varies with different localities. It may also vary with the different hours of the day.

While a national survey indicates that the average voltage for the USA is about 113 to 115 volts, it does not mean that every locality maintains a constant voltage at that level.

4

Occasionally we have had the complaint that a used tube will test GOOD, but will not work in the radio receiver; but when a NEW tube is substituted, the receiver will operate correctly. The answer is this: Tubes are built to specifications. Our tube testers are designed to test tubes in conformity with these specifications.

The used tube that would not perform in a certain receiver was not receiving its specified filament voltage. The new tube performed because of its initial reserve capacity. The used tube would have performed if it had received its specified filament voltage.

Tube failure frequently occurs in A.C.--D.C. sets where several tubes are connected with their heaters or filaments in series. Sometimes, even though the power line voltage is normal, a series tube with abnormally high filament resistance will rob its companion tube of its normal filament voltage. The robbed tube apparently fails; but when tested under specified conditions, the tube will test GOOD.

15. The wonderful versatility of the Hickok Dynamic Mutual Conductance Tube Tester makes possible a special test that will reveal a tube's ability to perform under adverse conditions as mentioned above. This is possible because the tester measures mutual conductance instead of emission.

THE TEST.

a. Measure the mutual conductance in the ordinary way.

b. Set the MICROMHO range switch on ENGLISH.

c. Press P4 and adjust the ENGLISH dial until the tube reads in the GREEN (GOOD) sector at 2000 on the scale.

d. While holding everything else constant, reduce the FILAMENT voltage and note new reading.

e. If the meter still reads in the GREEN (GOOD) sector, the tube has a large life reserve and will perform satisfactorily.



f. The filament voltage reductions to be made are shown in the following table:

NORMAL FIL. VOLTS	REDUCE TO
1.5	1.1
2.0	1.5
2.5	2.0
3.0	2.5
5.0	4.3
6.3	5.0
7.5	6.3
10.0	7.5
12.6	10.0

16. CONTINUITY TEST.--The Model 532 Tube Tester can be used to test for continuity through resistance up to 200,000 ohms.

- Set SHORTS switch on position 4.
- Connect two leads having prods and pin tips to the jacks marked PLATE and GRID.
- Touch the prods to the terminals through which continuity is to be determined.
- The neon lamp will glow if circuit is continuous.

TO TEST BALLAST TUBES

- Turn Tester on.
- Set filament switch to BLST.
- Set SHORT TEST switch on 1.
- Set first selector switch (lettered A to K) to letter shown in column marked (first selector switch).
- ROTATE second selector switch (lettered P to Z) from P to Z. NEON LAMP SHOULD LIGHT IN POSITIONS NOTED.

TUBE TYPE	First Selector	Neon lamp should light in these positions.					
		R	S	T	U	V	X
1A1-1B1-1C1-1E1-1F1-1G1-1J1-1K1-1L1-1M1-1P1-1Q1-1R1G-1S1G-1T1G-1U1G-1V1-1Y1-1Z1-2	J	R					
2UR224	J			T			X
2LR212	H	R	S		U		
3	J	R					
03G	J			T			
4-5	J	R					
6-133	J			T			
6-6AA	J	R					
7-8-9	J	R					
10A-10AG	J			T			
10AB	J			T			X
K17B-M17C-BM17C	J			T			X
M17HG-M17H	J D	R	S				X
K23B-K23C-KX23B-KX30C	J			T			X
M30H	J D	R	S				X
30A-K30A	J			T			
K30D	J	R		T			X
33A-33AG	J			T			
K34B	J			T			X

5



TUBE TYPE	First Selector	Neon lamp should light in these positions.					
36A	J			T			
K36B-BK36B-L36C-EM-L36C-KX36C	J			T			X
KX36A	J	R					
36D-L36D	J	R		T			X
L36DJ	J	R		T	U		X
K36H-M36H-M36HG	J D	R	S				X
L40S1-L40S2	J	R		T		V	
42A	J			T			
42A1	H				U		
42A2-42B2	H		S		U		
K42B-L42B-M42B-KX42B-LX42B-L42BX-K42C-L42C-M42C	J			T			X
KB42D-K42D-L42D	J	R		T			X
LX42D-L42DX	J	R	S	T			
K42E-L42E	J			T			X
L42F	J D	R					X
42HA-K42HJ-M42H-M42HG	J E	R	S	T			X
KX42C	J			T			X
L42S1	J	R		T		V	
49A-49AJ-K49AJ	J			T			
KX49A	J			T			X
49A1	H				U		
49A2-49B2	H		S		U		
K49B-L49B-M49B-EM49B-K49C-M49C-EM49C-BK49C-K49E-L49E	J			T			X
K49D-BK49D-L49D	J			T			X
L49F	J D	R					X
M49H-M49HG	J D	R	S				X
KZ49B-KZ49C	J	R				V	
K49BJ-L49BJ	J			T	U		X
L49S2	J	R		T		V	
49AJ-K49AJ	J			T			
KX49B-LX49B-LX49C	J			T			X
L49DJ	J	R		T	U		X
L49S3	J	R		T		V	
50A2	J	R		T			
50A2M-50B2	J	R				V	
50X3	J	R					
K52H-M52H	J D	R	S				X



TUBE TYPE	First Selector	Neon lamp should light in these positions.					
K54B	J			T			X
55A-K55A	J			T			
55A1	H				U		
KX55A	J	R					
55B-K55B-M55B-EM55B-L55BQ-LX55B	J			T			X
55A2-55B2	H		S		U		
K55C-L55C-KX55C	J	R		T			
K55CP	J			T		V	X
K55D-L55D	J	R		T			X
L55E-M55E	J			T			X
L55F-M55F-BL55F	J D	R					X
K55H-M55H-M55HQ	J D	R	S				X
L55H1-L55H2	J	R		T		V	X
60R30G	J	R		T			
64.23	J			T			
67A	J			T			
K67B-L67B	J			T			X
L73B-K74B-L74B-CX74C	J			T			X
80A	J			T			
K79B-K80B-M80B-K80C-KX80B-L80B	J			T			X
K80F	J D	R					X
KX87B-LX87B-L90B	J			T			X
K90F-M90F-K92F-M92F	J D	R					X
92A	J			T			
L92B-95K2	J			T			X
L99D	J	R		T			X
100R8	J			T			X
120R	J	R					
120R8-135K1	J			T			X
135K1A	J			T	U		X
140L4-140L8-140R4-140R8	J	R		T			
140R	J	R					
140L44-140R44	J	R	S	T			
165L4-165R4-165R8	J	R		T			
165R	J	R					
165L44-165R44	J	R	S	T			
185L4-185L8-185R4-185R8	J	R		T			
185R	J	R					
185L44-185R44	J	R	S	T			
200R-250R	J	R					
250R8-290L4	J			T			X
300R4-320R4	J			T			X
340	J	R					
808-1	J			T	U		X
E14980-W43357-W4588-3613	J			T			X
3334-3334A	J	R		T			X
8593-8598-8601-8664	J			T			X
3CR248	J	R		T	U		X
3CR241	J	R		T			X



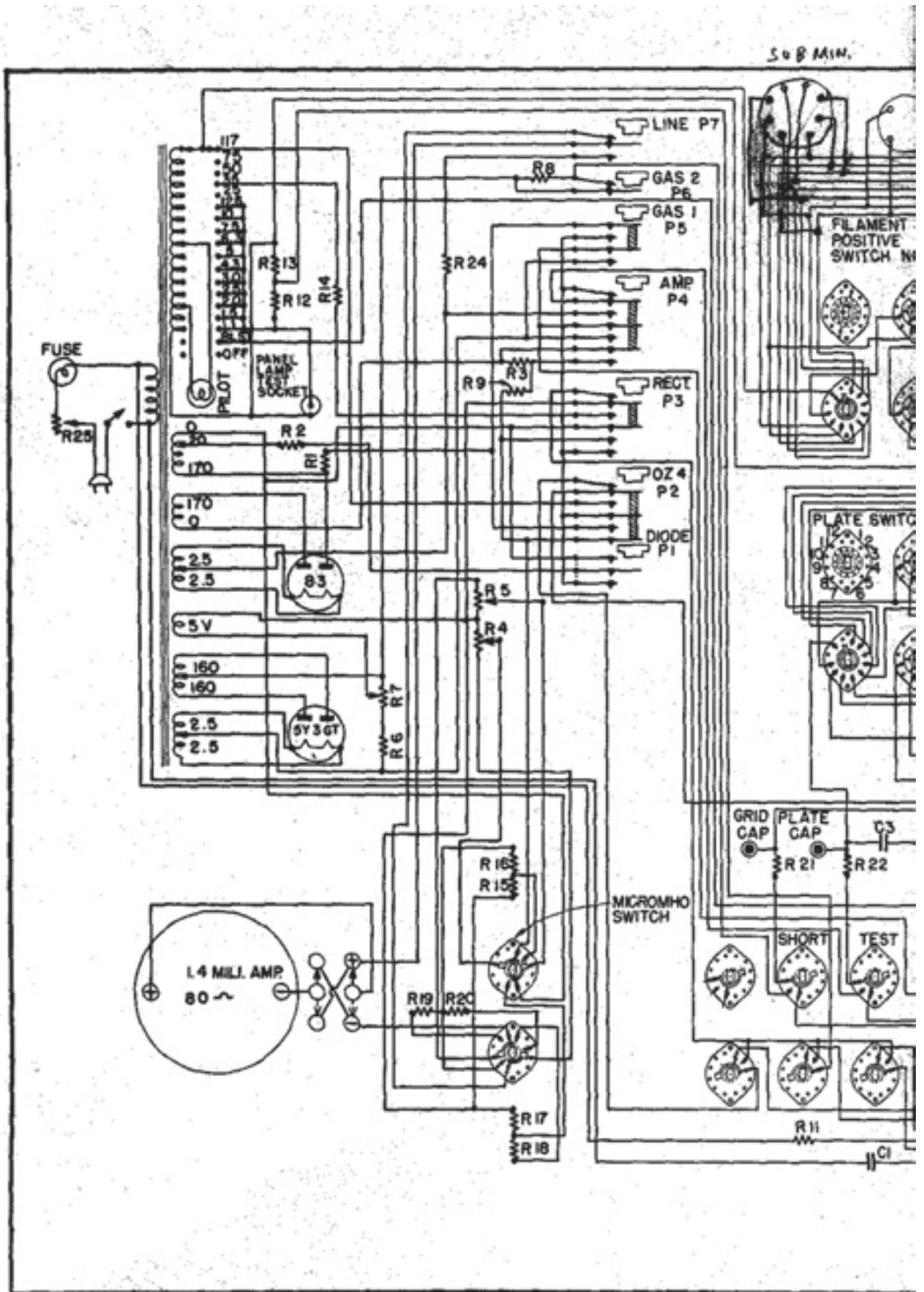

Schematic Drawing of M



DRAWING NUMBER
608 W

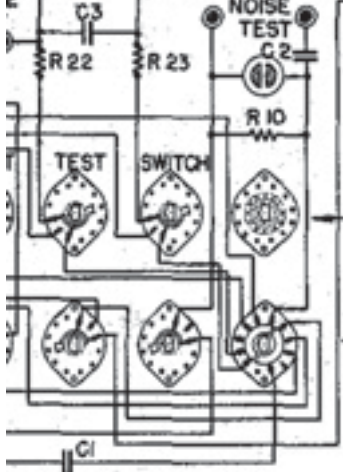
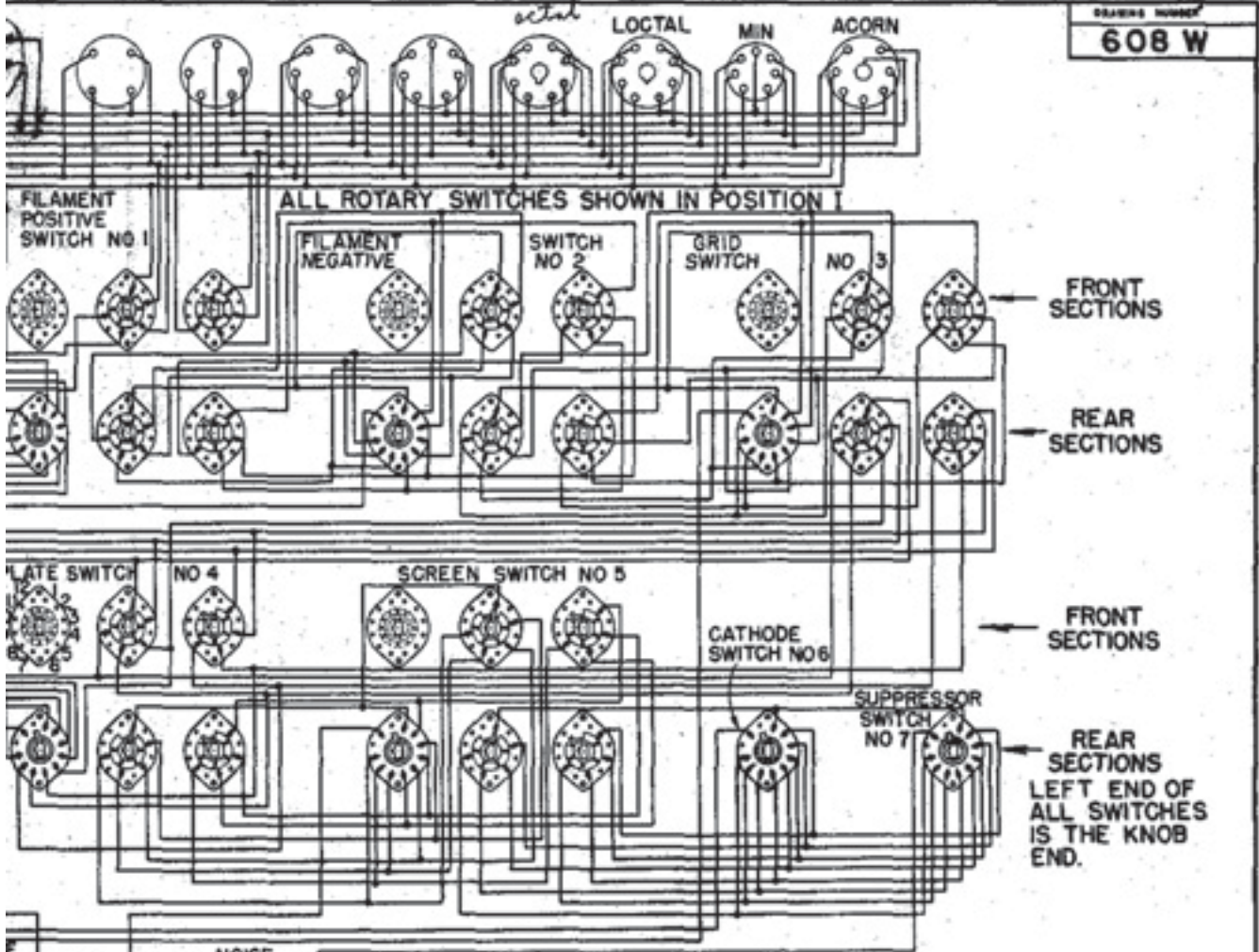

R1	1800 \sim
R2	1200 \sim
R3	15000 \sim
R4	150 \sim
R5	150 \sim DUAL POT
R6	6000 \sim
R7	5000 \sim POT.
R8	180,000 \sim
R9	15 \sim - ADJUST
R10	500,000 \sim
R11	15,000 \sim
R12	50 \sim
R13	50 \sim
R14	150 \sim

R15	41 \sim
R16	109 \sim
R17	41 \sim
R18	109 \sim
R19	70 \sim
R20	17 \sim ADJUST
R21	47 \sim
R22	47 \sim
R23	47 \sim
R24	215,000 \sim
R25	200 \sim
C1	1 MED - 400 VOLT
C2	.0005 - 1000 VOLT
C3	.0005 - 1000 VOLT

SCHEMATIC
MODEL 532 TUBE TESTER
THE HICKOK ELECTRICAL INSTRUMENT CO.
CLEVELAND, OHIO

TITLE SCHEMATIC			
DATE	BY	QA	SCALE
1/15/55	J.S.		
DATE	APPROVED	DATE	NO.
5/5	J.S.	6/15/55	608 W

Fig of Model 532 Tube Tester



Reworked by
PAØPGA

This manual was downloaded from **BAMA's**
boatanchor site <http://bama.sbc.edu>





K4XL's

BAMA

This manual is provided free of charge from the "Boatanchor Manual Archive", as a service to the Boatanchor community. It was uploaded by someone who wanted to help you repair and maintain your equipment.

If you paid anyone other than **BAMA** for this manual, you paid someone who is making a profit from the free labor of others, without asking their permission

You may pass on copies of this manual to anyone who needs it. But do it without charge.

Thousands of files are available without charge from **BAMA**. Visit us at: <http://bama.sbc.edu>

**Real radio's have tubes!
Keep them glowing !!**

File credits:

Ross Stovall

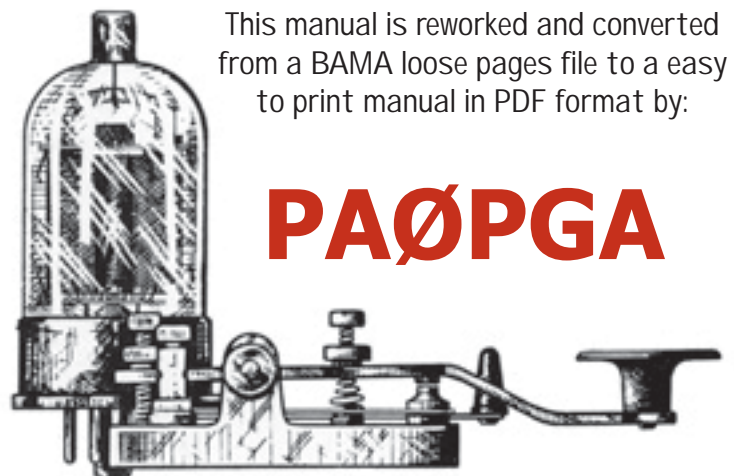

This manual is reworked and converted from a BAMA loose pages file to a easy to print manual in PDF format by:

PAØPGA

