

MAIN SWITCH & ROLL CHART ASSEMBLY

1. Fig. 3. Attach one #6-32 speed-nut to the left and to the right bracket, as shown. Note that one side of the speed-nut is flat; attach it so that the other side lies in the "valley" of the brackets.

2. Fig. 3. Attach the "Line" push-button switch, S27, to the left bracket as shown. Use two #4-40 screws and two #4 lockwashers.

3. Fig. 3. Attach the "Merit" lever switch, S28, to the right bracket as shown. Use one #6-32 screw and one #6 lockwasher for the tapped post, and one #6 self-tapping screw for the hole in the bracket.

4. Fig. 3. Attach the calibrating pots. R7 and R18 as shown. These may either be of the snap-in (blue shaft) or tab mount (black or metallic shaft) type. The snap-in type, as the name implies, is merely snapped into place. The tab mount types are inserted the same way, then the two tabs are bent in snugly toward the shaft.

5. Fig. 3. Attach the selenium rectifier, CR1, to the left bracket as shown. Use one #6 lockwasher and one #6-32 hex nut. Note the polarity shown (the terminal marked + should be away from the calibrating pot.).

6. Fig. 3. Attach the lever switch assembly, SA2, to the brackets as shown. Use 4 #6 lockwashers and 4 #6-32 hex nuts. Make certain that the studs are firmly seated in the slots before tightening the hex nuts.

7. Fig. 3. Attach the push-button switch assembly, SA1, to the brackets as shown. Note that the terminals must face toward SA2. Use two #6-32 screws.

8. Fig. 4. Attach four #6-32 speed nuts to the roll chart bracket as shown. Note that this type of speed nut has one flat side; this side is placed on the bracket so that it faces the mating flat surface (underside of the panel, in this case). The #6-32 speed-nuts are about the same physical size as the #8-32, but accommodate a smaller diameter screw.

9. Fig. 4. Attach the roll chart damper (small U-shaped phosphor-bronze spring) to the roll chart bracket, as shown. Use one #4-40 screw, one #4 lockwasher, and one #4-40 hex nut. The screw can be placed in either of the two holes in the bracket; the other hole accommodates the locating spur on the damper.

10. Fig. 4. Make up two roller assemblies, as shown. Use one roller, (be certain to remove the paper roll chart from one of the rollers) one rod, two drive gears, and two small push-on speed nuts for each. The rod should protrude equally from both ends.

11. Fig. 4. Insert the two roller assemblies into the brackets so that the drive gears mesh on each end.

After installing the roll chart assembly, see P.9 for instructions on attaching the roll chart (save the length of masking tape supplied for this purpose).

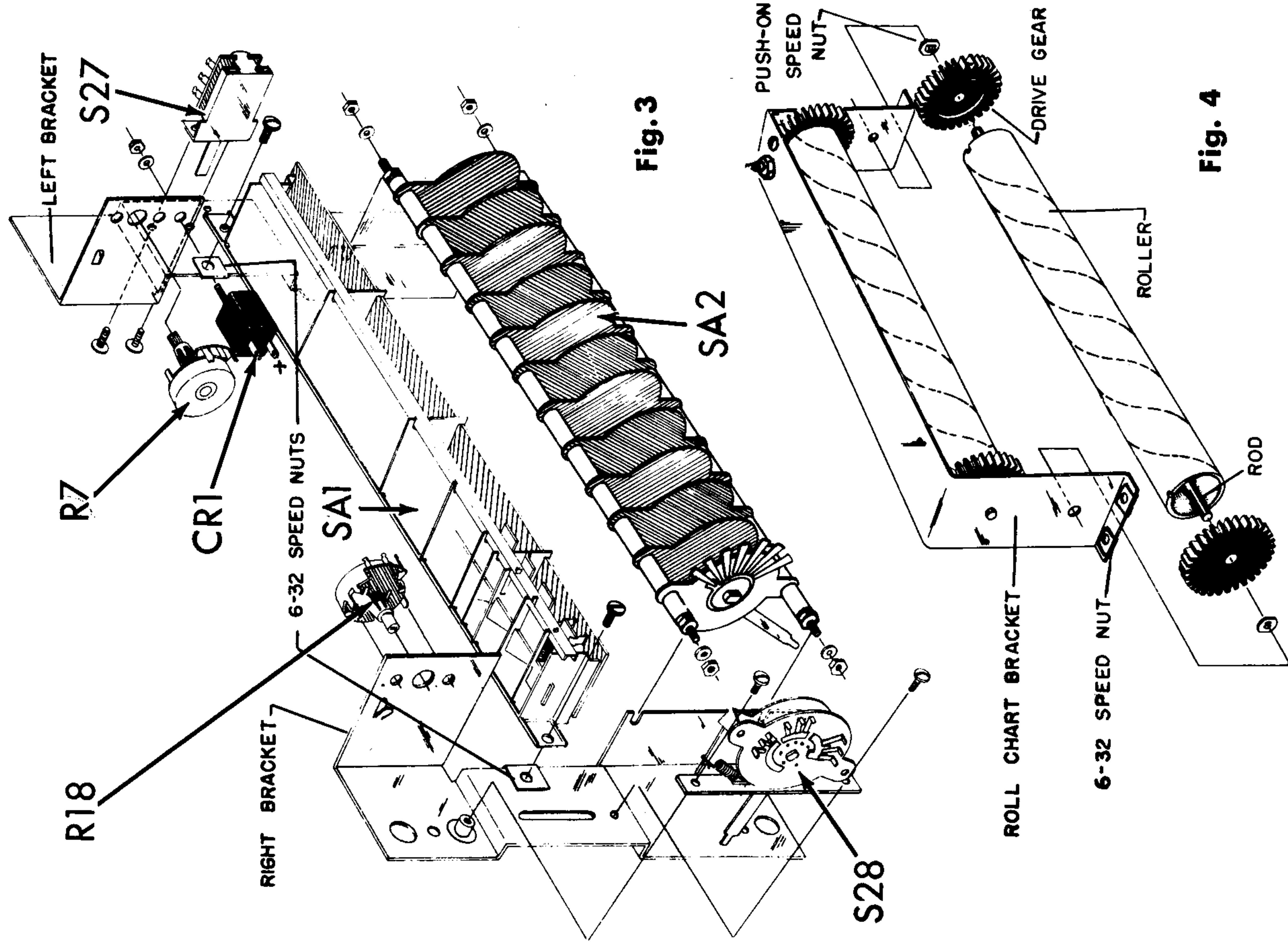

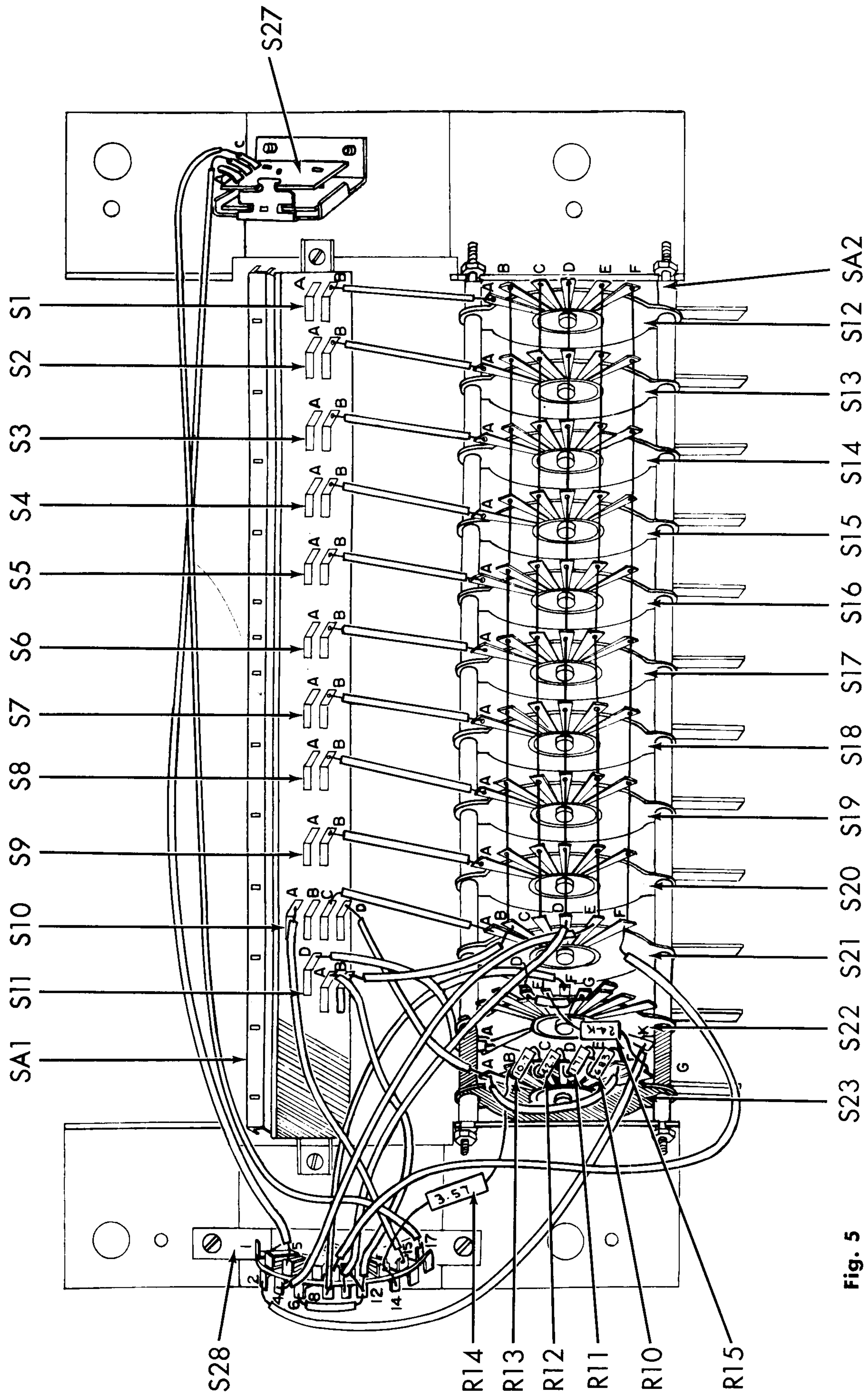

Fig. 5

SUB-ASSEMBLY WIRING

(✓) 1. Fig. 5. Connect short lengths of bare wire, covered with spaghetti, between each of the following pairs of points (solder both ends):

S1-B	to	S12-A
S2-B	to	S13-A
S3-B	to	S14-A
S4-B	to	S15-A
S5-B	to	S16-A
S6-B	to	S17-A
S7-B	to	S18-A
S8-B	to	S19-A
S9-B	to	S20-A
S10-C	to	S21-A

(✓) 2. Fig. 5. Run one end of an 8" length of bare wire thru S12-B. Continue running it thru S13-B, S14-B, etc., finally connecting it to S21-B. Do not solder yet.

(✓) 3. Fig. 5. Repeat the above for S12-C thru S21-C.

(✓) 4. Fig. 5. Repeat the above for S12-D thru S21-D.

(✓) 5. Fig. 5. Repeat the above for S12-E thru S21-E.

(✓) 6. Fig. 5. Repeat the above for S12-F thru S21-F.

Now solder all the connections on S12 to S21 except the following:

S12 - B, C
 S21 - B, D, E, F

(✓) 7. Fig. 5. Connect one end of a 3" red lead to S22-A (S). Connect the other end to the dummy lug, S11-D (C).

(✓) 8. Fig. 5. Connect a short length of bare wire, covered with spaghetti, from S22-D (C) to S22-G (S).

(✓) 9. Fig. 5. Connect a short length of bare wire, covered with spaghetti, from S21-B (S) to S11-B (S).

(✓) 10. Fig. 5. Connect one end of a 3" blue lead from S10-D (S) to S23-A (C).

(✓) 11. Fig. 5. Connect one end of a short bare lead, covered with spaghetti, from S23-A (C) to S23-F (C).

(✓) 12. Fig. 5. Connect the 24K 1W resistor, R15, from S22-E (C) to S23-G (S).

(✓) 13. Fig. 5. Connect the 683 ohm resistor, R10, from S23-F (S) to S23-E (C).

(✓) 14. Fig. 5. Connect the 171 ohm resistor, R11, from S23-E (S) to S23-D (C).

(✓) 15. Fig. 5. Connect the 42.7 ohm resistor, R12, from S23-D (S) to S23-C (C).

(✓) 16. Fig. 5. Connect the 10.7 ohm resistor, R13, from S23-C (S) to S23-B (C).

(✓) 17. Fig. 5. Connect one end of the 3.57 ohm resistor, R14, to S23-B (S). Pass the other end thru S28-13 and connect to S28-14. Solder both points.

(✓) 18. Fig. 5. Connect a 5" violet lead from S10-A (S) to S28-15 (S).

(✓) 19. Fig. 5. Connect a 6" white lead from S21-F (S) to S28-9 (S).

(✓) 20. Fig. 5. Connect a 7" brown lead from S21-E (S) to S28-4 (S).

(✓) 21. Fig. 5. Connect a 6" yellow lead from S21-D (S) to S28-10 (S).

(✓) 22. Fig. 5. Connect a 4" black lead from S11-A (S) to S28-11 (S) and 12 (C).

(✓) 23. Fig. 5. Connect a short length of bare wire covered with spaghetti from S28-6 (S) to S28-12 (S).

(✓) 24. Fig. 5. Connect a 6" orange lead from S22-F (S) to S28-8 (S).

(✓) 25. Fig. 5. Connect a 8" red lead from S22-K (S) to S28-2 (S).

(✓) 26. Fig. 5. Connect a 15" grey lead from S28-17 (S) to S27-C (S).

(✓) 27. Fig. 5. Connect a 14" blue lead from S28-5 (S) to S27-B (S).

PANEL WIRING

Connect the tube sockets according to the following chart (note that the 3-terminal transistor socket is NOT included):

* B/S indicates bare lead covered with spaghetti.

	<u>COLOR</u>	<u>LENGTH</u>	<u>FROM</u>	<u>TO</u>
1.	() Brown	2"	XV1-1 (C)	XV2-1 (C)
2.	() Red	2 1/2	XV1-2 (C)	XV2-2 (C)
3.	() Orange	3	XV1-3 (C)	XV2-3 (C)
4.	() Yellow	3 1/2	XV1-4 (C)	XV2-4 (C)
5.	() Green	5	XV1-5 (C)	XV2-5 (C)
6.	() Blue	4 1/2	XV1-6 (C)	XV2-6 (C)
7.	() Violet	4	XV1-7 (C)	XV2-7 (C)
8.	() Grey	3 1/2	XV1-8 (C)	XV2-8 (C)
9.	() Brown	2	XV2-1 (S)	XV3-1 (C)
10.	() Red	2 1/2	XV2-2 (S)	XV3-2 (C)
11.	() Orange	3	XV2-3 (S)	XV3-3 (C)
12.	() Yellow	3 1/2	XV2-4 (S)	XV3-4 (C)
13.	() Green	5	XV2-5 (S)	XV3-5 (C)
14.	() Blue	4 1/2	XV2-6 (S)	XV3-6 (C)
15.	() Violet	4	XV2-7 (S)	XV3-7 (C)
16.	() Grey	3 1/2	XV2-8 (S)	XV3-8 (C)
17.	() Brown	8 1/2	XV3-1 (S)	XV4-1 (C)
18.	() Red	8 1/2	XV3-2 (S)	XV4-2 (C)
19.	() Orange	8 1/2	XV3-3 (S)	XV4-3 (C)
20.	() Yellow	13	XV3-4 (S)	XV4-4 (C)
21.	() Green	13	XV3-5 (S)	XV4-5 (C)
22.	() Blue	8 1/2	XV3-6 (S)	XV4-6 (C)
23.	() Violet	9 1/2	XV3-7 (S)	XV7-7 (C)
24.	() Grey	12	XV3-8 (S)	XV9-8 (S)
25.	() Brown	3 1/2	XV4-1 (C)	XV5-1 (C)
26.	() Red	4	XV4-2 (C)	XV5-2 (C)
27.	() Orange	5	XV4-3 (C)	XV5-3 (C)
28.	() Yellow	4	XV4-4 (C)	XV5-4 (C)
29.	() Green	3	XV4-5 (C)	XV5-5 (S)
30.	() Brown	3 1/2	XV5-1 (S)	XV6-1 (S)
31.	() Red	4	XV5-2 (S)	XV6-2 (S)
32.	() Orange	5	XV5-3 (S)	XV6-3 (S)
33.	() Yellow	3	XV5-4 (S)	XV6-4 (S)
34.	() Brown	3 1/2	XV4-1 (S)	XV7-1 (C)
35.	() Red	3 1/2	XV4-2 (S)	XV7-2 (C)

36.	() Orange	3 1/2	XV4-3 (S)	XV7-3 (C)
37.	() Yellow	3 1/2	XV4-4 (S)	XV7-4 (C)
38.	() Green	3	XV4-5 (S)	XV7-5 (C)
39.	() Blue	3	XV4-6 (S)	XV7-6 (C)
40.	() Brown	3	XV7-1 (C)	XV8-1 (C)
41.	() Red	5	XV7-2 (C)	XV8-2 (C)
42.	() Orange	4 1/2	XV7-3 (C)	XV8-3 (C)
43.	() Yellow	4	XV7-4 (C)	XV8-4 (C)
44.	() Green	3	XV7-5 (C)	XV8-5 (C)
45.	() Blue	3	XV7-6 (C)	XV8-6 (C)
46.	() Violet	3 1/2	XV7-7 (C)	XV8-7 (C)
47.	() * B/S		XV7-1 (S)	XV9-1 (S)
48.	() * B/S		XV7-2 (S)	XV9-2 (S)
49.	() * B/S		XV7-3 (S)	XV9-3 (S)
50.	() * B/S		XV7-4 (S)	XV9-4 (S)
51.	() * B/S		XV7-5 (S)	XV9-5 (S)
52.	() * B/S		XV7-6 (S)	XV9-6 (S)
53.	() * B/S		XV7-7 (S)	XV9-7 (S)
54.	() * B/S		XV8-1 (S)	XV10-1 (S)
55.	() * B/S		XV8-2 (S)	XV10-2 (S)
56.	() * B/S		XV8-3 (S)	XV10-3 (S)
57.	() * B/S		XV8-4 (S)	XV10-4 (S)
58.	() * B/S		XV8-5 (S)	XV10-5 (S)
59.	() * B/S		XV8-6 (S)	XV10-6 (S)
60.	() * B/S		XV8-7 (S)	XV10-7 (S)
61.	() * B/S		XV3-5 (S)	GND "A" (S)

(See Fig. 8)

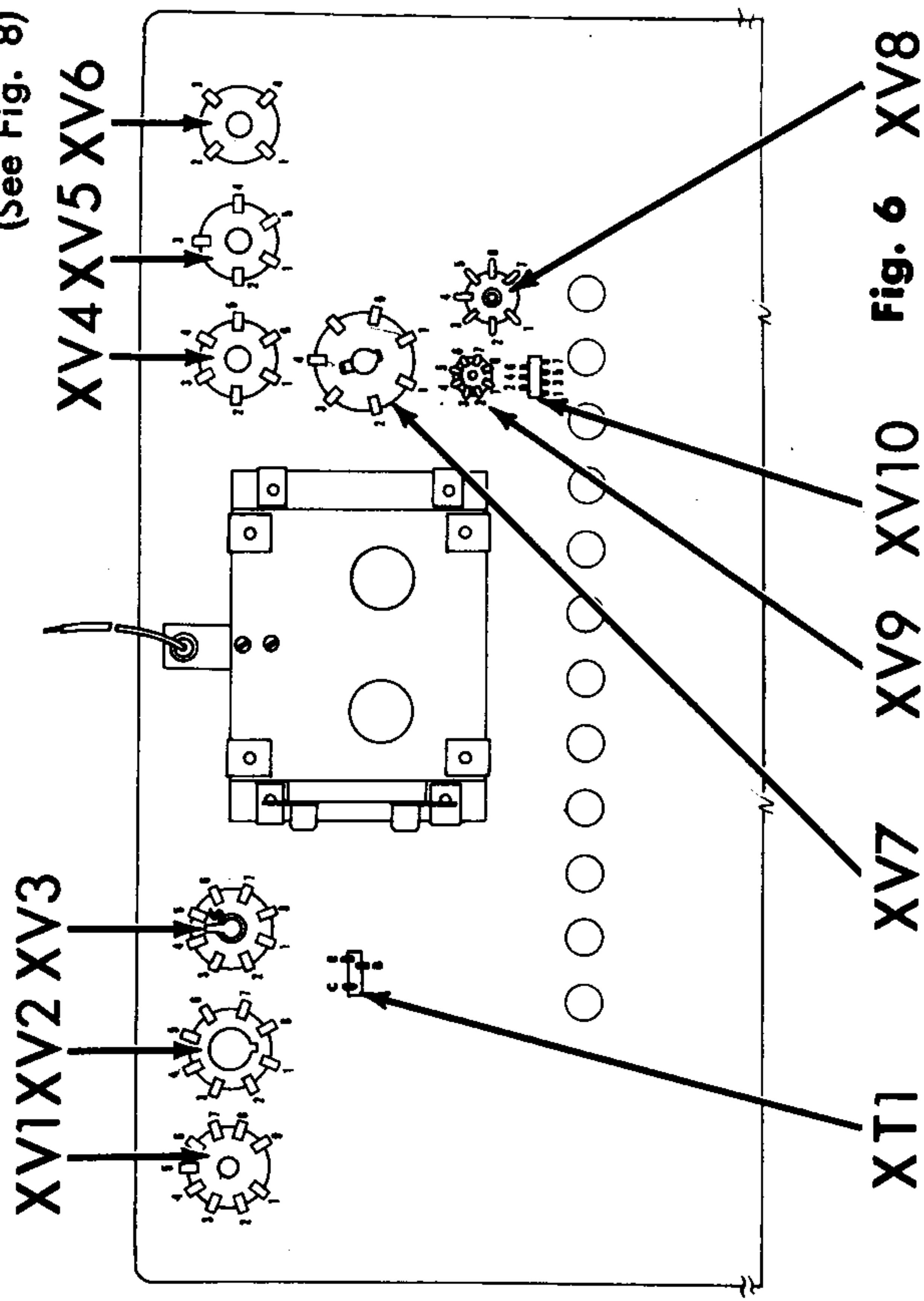

TRANSISTOR SWITCH WIRING

- (✓) 1. Fig. 7. Connect a short length of bare wire, covered with spaghetti, from S25-7A (S) to S25-7B (C).
- (✓) 2. Fig. 7. Connect the 129 ohm resistor, R5, from S25-7B (S) to 25-9B (C).
- (✓) 3. Fig. 7. Connect a short length of bare wire, covered with spaghetti, from S25-9A (C) to S25-9B (C).
- (✓) 4. Fig. 7. Connect the 50 ohm resistor, R6, from S25-8 (S) to S25-9B (S).
- (✓) 5. Fig. 7. Connect the 680 ohm resistor, R2, from S25-9A (C) to S25-2 (C).
- (✓) 6. Fig. 7. Connect the cathode end (identified by a stripe or similar mark) of the 1N48 diode, CR2, to S25-2 (C). Connect the unmarked end to S25-12 (C).
- (✓) 7. Fig. 7. Connect the POSITIVE (+) end of the 10mfd/25 volt capacitor, C2, to S25-2 (S). When soldering this connection, it is advisable to protect the 1N48 diode from overheating. This may be done by holding the lead of the 1N48 going to S25-2 with a pair of pliers, or by fastening an alligator clip or similar device to the lead in order to dissipate as much heat as possible. Use a fairly hot iron, well finned, and solder as quickly as possible. Connect the other end of C2 to S25-9A (C).
- (✓) 8. Fig. 7. Connect one end of a 3" bare lead to S25-9A (S). Leave the other end free.
- (✓) 9. Fig. 7. Connect one end of the 1K resistor, R4, to S25-3 (S) so that 1/2" of lead extends between the resistor and the terminal. Leave the other end free.
- (✓) 10. Fig. 7. Connect one end of the 200K resistor, R3, to S25-4 (S) so that 1" of lead extends between the resistor and the terminal. Leave the other end free.
- (✓) 11. Fig. 7. Connect one end of a 2" bare wire to S25-1 (S). Leave the other end free.
- (✓) 12. Fig. 7. Connect one end of an 11" orange lead to S25-12 (S). A gain, use an alligator clip or similar device between the 1N48 and S25-12. Leave the other end of the orange lead free.

(✓) 13. Fig. 7. Connect one end of a 6" black lead to S25-11 (S). Leave the other end free.

(✓) 14. Fig. 7. Connect one end of a 5" red lead to S25-6 (S). Leave the other end free.

(✓) 15. Fig. 7. Connect and solder a meter mounting lug (packed in the meter box) to one end of a 7" red lead. Connect the other end of the lead to S25-5 (S).

(✓) 16. Fig. 7. Connect and solder the second meter mounting lug to one end of an 8" black lead. Connect the other end of the lead to S25-10 (S).

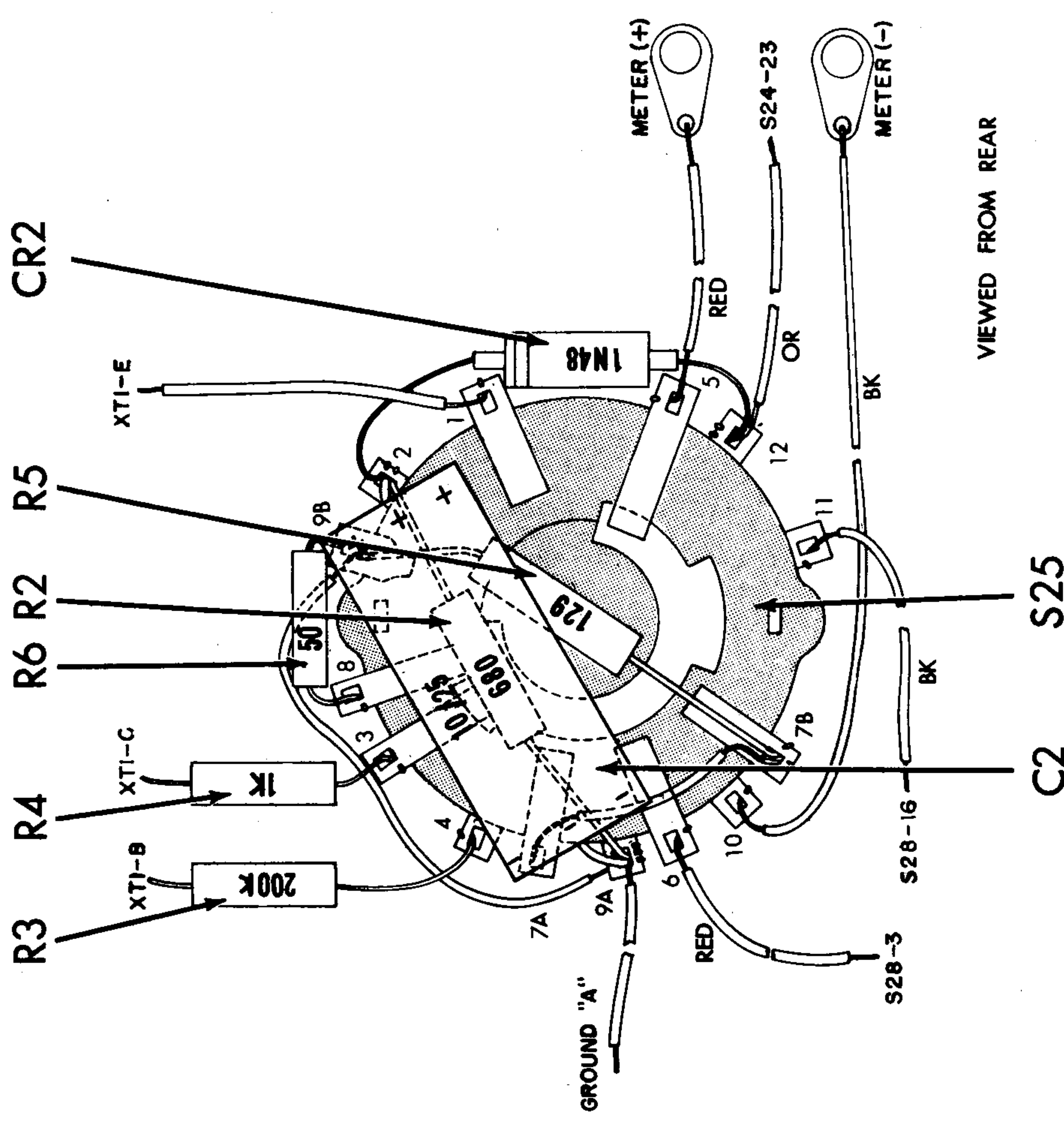

Fig. 7

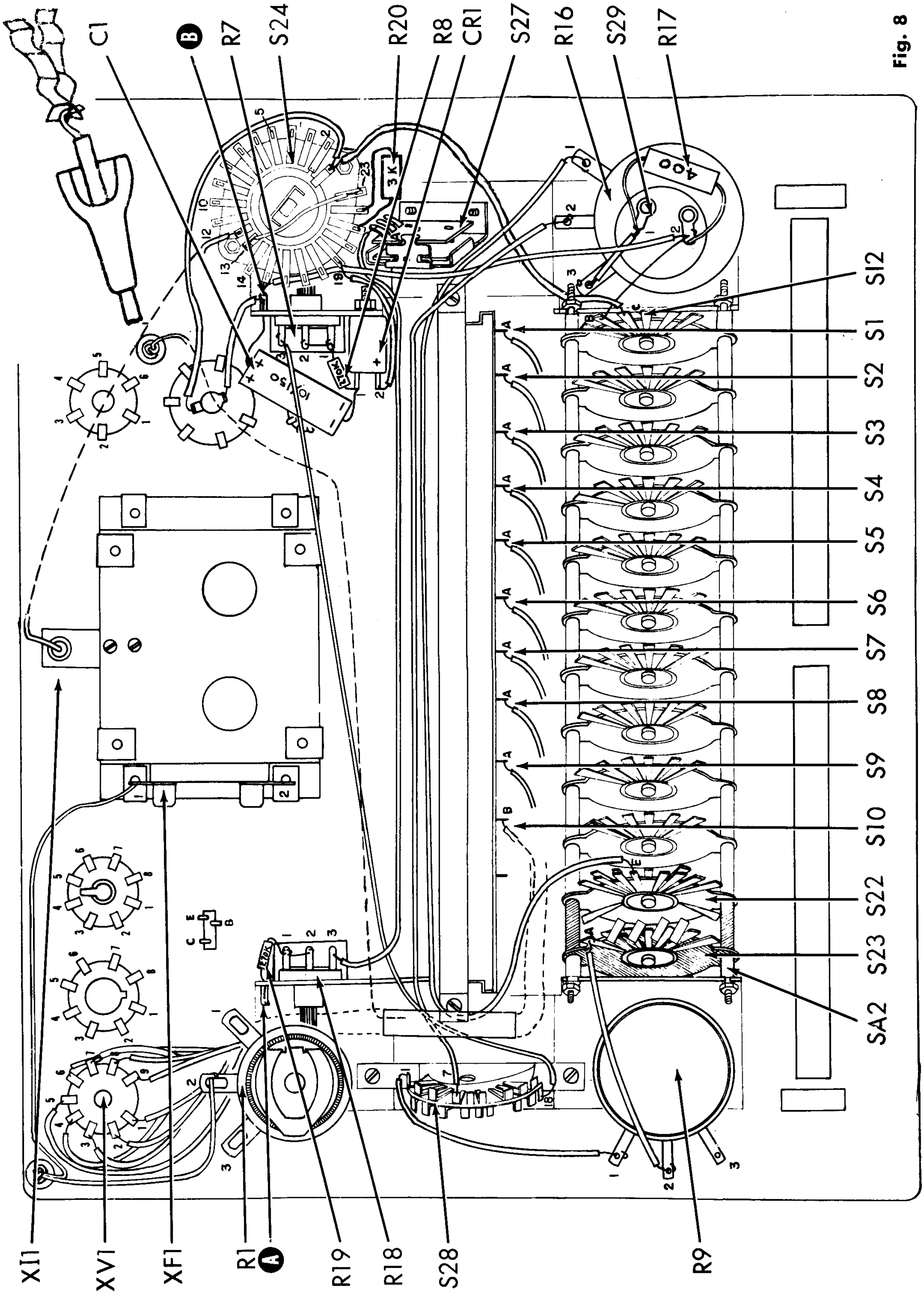

Fig. 8

ASSEMBLY AND WIRING OF SUB-CHASSIS TO PANEL

- (✓) 1. Fig. 8. Set the 12 levers of SA2 to the mid-position and insert the switch sub-assembly into the panel. Note that lever V fits into a shorter slot than the others; position this lever accordingly.
- (✓) 2. Fig. 8. Note that the filament switch, S24, has a small locating key. Place a 3/8" flat washer over the shaft and insert this switch thru the appropriate holes in the bracket and panel so that the key engages the mating hole in the bracket. Fasten it loosely to the panel with a 3/8" nut.
- (✓) 3. Fig. 8. In the same manner, loosely fasten R1, R9, and R16 in their respective holes. Use one 3/8" flat washer and one 3/8" nut with each. Make sure that the locating keys engage the bracket holes properly.
- (✓) 4. Fig. 8. Press a small red knob on the LINE and MERIT switch shafts. Place the small black knobs on the remaining 24 push-button and lever shafts. Check to see that all levers and knobs fit their respective slots and holes, then tighten the panel nuts holding S24, R1, R9, and R16.
- (✓) 5. Fig. 8. Connect the white lead from the pilot light assembly, XI1, to S24-12 (C).
- (✓) 6. Fig. 8. Connect a short piece of bare wire, covered with spaghetti, from S24-13 (C) to S24-23 (C).
- (✓) 7. Fig. 8. Connect the 3K 5W resistor, R20, from S24-21 (C) to S24-22 (S).
- (✓) 8. Fig. 8. Connect a short piece of bare wire, covered with spaghetti, from the terminal connected to the shell of the pilot light base in XV7 (S) to ground "B" (C).
- (✓) 9. Fig. 8. Connect a 6" yellow lead from the center terminal of the pilot light base in XV7 (S) to S24-1 (C).
- (✓) 9a. Fig. 8. Connect a 7" yellow lead from S24-1 (S) to S12-C (S).
- (✓) 10. Fig. 8. Connect one end of a 270K resistor, R8 to R7-1 and 2 (solder both). Connect the other end to CR1-1 (C).
- (✓) 11. Fig. 8. Connect a 4" yellow lead from CR1-2 (S) to S24-19 (C).
- (✓) 12. Fig. 8. Connect the positive (+) end of the 10mfd/150V capacitor, C1, to ground "B" (C). Connect the negative (-) lead to CR1-1 (S).
- (✓) 13. Fig. 8. Connect a 14" red lead from R7-3 (S) to S28-18 (S).

- (✓) 14. Fig. 8. Connect a 14" brown lead from S27-A (S) to R18-3 (S).
- (✓) 15. Fig. 8. Connect one end of the second 270K resistor, R19, to R18-1 and 2 (solder both). Connect the other end to ground "A" (C). *SEE # 61-66*
- (✓) 16. Fig. 8. Connect an 8" black lead from ground "B" (S) to S29-2 (C).
- (✓) 17. Fig. 8. Connect the 400Ω 5W resistor, R17, from S29-1 (C) to S29-2 (C).
- (✓) 18. Fig. 8. Connect a short piece of bare wire, covered with spaghetti, from S29-2 (S) to S12-B (S).
- (✓) 19. Fig. 8. Connect a short piece of bare wire, covered with spaghetti, from R16-3 (S) to S29-1 (C).
- (✓) 20. Fig. 8. Connect a 16" green lead from R16-2 (S) to S28-7 (S).
- (✓) 21. Fig. 8. Connect a 20" yellow lead from R16-1 (S) to S22-E (S).
- (✓) 22. Fig. 8. Connect a 5" green lead from R9-1 (S) to S28-1 (S).
- (✓) 23. Fig. 8. Connect a 4" blue lead from R9-2 (S) to S23-A (S).
- (✓) 24. Fig. 8. Connect and solder one end of the following leads:

LEAD	TO	LEAD	TO
Brown - 17"	S1-A	Yellow - 15 1/2"	S4-A
Red - 16 1/2"	S2-A	Green - 15"	S5-A
Orange - 16"	S3-A	Blue - 14"	S6-A
Connect one end of the black kinkless lead to S10-B.		White - 11"	S9-A
- (✓) 25. Fig. 8. Form the above leads together neatly and pass a 3" length of tubing over the free end. Pass the tubing up so that it protects and binds the leads as they bend around SA1.
- (✓) 26. Fig. 8. Connect and solder the above leads to XV1 as follows: Brown to pin 1, Red to pin 2, Orange to pin 3, Yellow to pin 4, Green to pin 5, Blue to pin 6, Violet to pin 7, Grey to pin 8, and White to pin 9.
- (✓) 27. Fig. 8. Knot the black rubber-covered lead 12" from the free end and pass thru the small grommet. Solder the free end to the plate-and-grid cap.
- (✓) 28. Fig. 8. Pass the line cord thru the large grommet so that the stripped end will be behind the panel. Knot the line cord 6" from the free end. Connect one end to XF1-1 (S) and the other end to R1-2 (S).

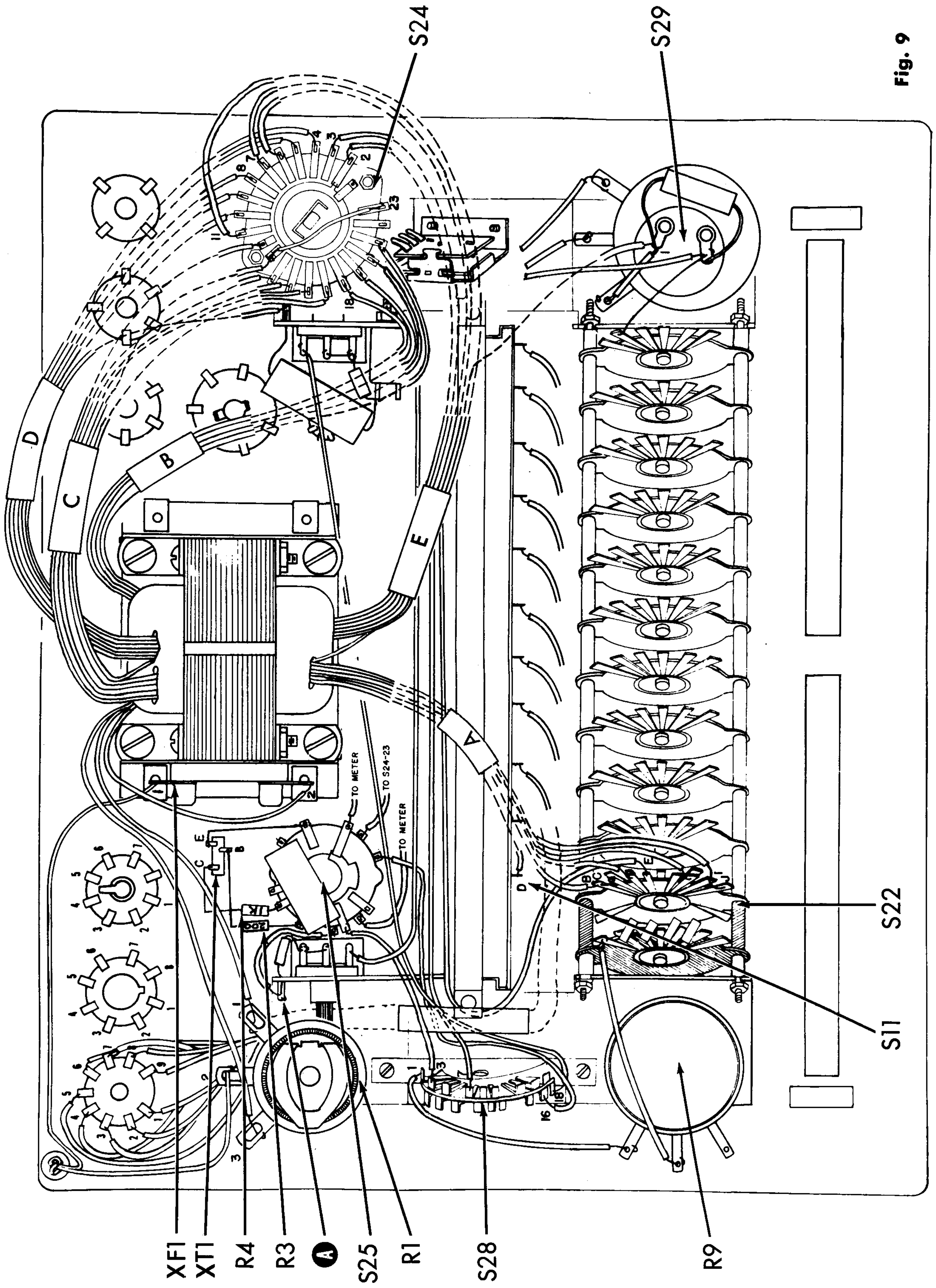

Fig. 9

You have now completed the assembly and wiring of your instrument. When you have completed the following steps your instrument will be ready for use.

- 1) To catch any wiring errors, it is suggested that the entire wiring be checked point-by-point against the wiring instructions (and preferably also against the schematic wiring diagram in order to become more familiar with the component layout and circuitry). While doing so, check for rosin joints, loose lumps of solder, poor lead dress, and accidental shorts or leakage paths arising from the flow of rosin between contacts (remove with a stiff brush dipped in carbon tetrachloride, being careful not to spring contacts when cleaning switches).
- 2) Before connecting to the a-c line, make the following resistance checks across the prongs of the a-c line plug: a) with the LINE ADJUST control set at AC-OFF, the resistance measurement should show an open circuit; b) with the LINE ADJ. turned clockwise from 130 to 105, the resistance should vary between approximately 15 and 75 ohms.

3) Insert the a-c plug in the 105-130 volt, 60 cps line outlet and set up the tester controls as follows: C lever at position 2, all other levers at position 1; LINE ADJUST control set at 115; FILAMENT voltage selector set at zero; TRANSISTOR TEST selector set at "TUBE"; GRID control set at 100; PLATE control set at zero. Clip one lead of an a-c voltmeter to the roll chart bracket (ground) and the other voltmeter lead to the top cap. Keeping the a-c voltmeter always at a higher range than the voltage to be measured, turn the FILAMENT selector clockwise and read the a-c voltage at every position up to 117 on the dial. (Note that since the LINE CAL. and LEAK CAL. potentiometers have not been adjusted as yet, line adjustment has not been made and the voltages read may differ by as much as 25% from their nominal values.) Now move the C level to position 3 (screen), depress push-button C, and read the a-c voltages between the cap lead and ground for every position of the V lever, while holding down the MERIT lever. Do likewise with the C lever set at position 4 (plate), and position 5 (grid). The voltages to be expected are tabulated below. Remember to always set the a-c voltmeter at a range higher than the voltage expected and note the $\pm 25\%$ tolerance in accuracy holds for these measurements also.

		Lever C pos.				
		3	4	5		
Lever V pos.	1	15V	45V	5V		
	2	45	90	15	2.0	
	3	90	180	15	6.0	
	4	90	180	45	15.0	1.0

When done, release the MERIT lever and disconnect the top cap from the voltmeter.

- 4) Check for a dc voltage of -70 volts ($\pm 25\%$) from the negative lead of C1

to ground, and a dc voltage of +6 volts ($\pm 25\%$) from the plus lead of C2 to ground.

5) Measure the dc voltage across the E and C terminals of the transistor test socket XT1, with the plus voltmeter lead going to C, for each position of the TRANSISTOR test selector. There should be no voltage reading at the "TUBE" position and a reading of +6 volts dc at the "N-P-N 1" and "N-P-N 2" positions. With the test leads reversed there should be a reading +6 volts dc at the "P-N-P 1" and "P-N-P 2" positions.

6) If any of the above readings do not check (allowing for a $\pm 25\%$ tolerance), a careful inspection of the wiring should be made. Do not proceed to use the tester before this is done. **IMPORTANT:** The procedures just described constitute only a partial check-out of the tester intended to prevent damage to the instrument. Other wiring errors might still exist. It is up to the kit builder to work carefully and to go over all the wiring to make certain that all the required connections have been made correctly and soldered properly.

7) Before the instrument will operate as intended, the LINE CAL and LEAK CAL potentiometers must be adjusted as described in the MAINTENANCE section (page 8). Make these adjustments and then proceed to the remaining steps below.

8) Install the completed tester in the cabinet, positioning the transformer in the retaining bracket on the bottom of the cabinet. Fasten with 14 self-tapping screws.

9) A matching cover has been provided to protect the instrument. The two prongs inside the cover may be used to store the line cord.

If the instrument fails to operate properly, recheck the wiring for errors or reversed connections, test for continuity, and check individual components for breakdown. If you are still having difficulty, write to our service department listing all possible indications that might be helpful. If desired, you may return the instrument to our factory where it will be placed in operating condition for \$8.50 plus the cost of parts replaced due to their being damaged in the course of construction. This service policy applies only to completed instruments constructed in accordance with the instructions as stated in the manual. Instruments that are not completed or instruments that are modified will not be accepted for repair. Instruments that show evidence of acid core solder or paste fluxes will be returned not repaired. See SERVICE paragraph at the end of the INSTRUCTION section for shipping instructions.

K4XL's **BAMA**

This manual is provided **FREE OF CHARGE** from the "BoatAnchor Manual Archive" as a service to the Boatanchor community.

It was uploaded by someone who wanted to help you repair and maintain your equipment.

If you paid anyone other than BAMA for this manual, you paid someone who is making a profit from the free labor of others without asking their permission.

You may pass on copies of this manual to anyone who needs it. But do it without charge.

Thousands of files are available without charge from BAMA. Visit us at <http://bama.sbc.edu>