

Trainwreck Blues Express Version A5a

This version uses a Triode switch to smooth out the response (which is very harsh in the Pentode mode).

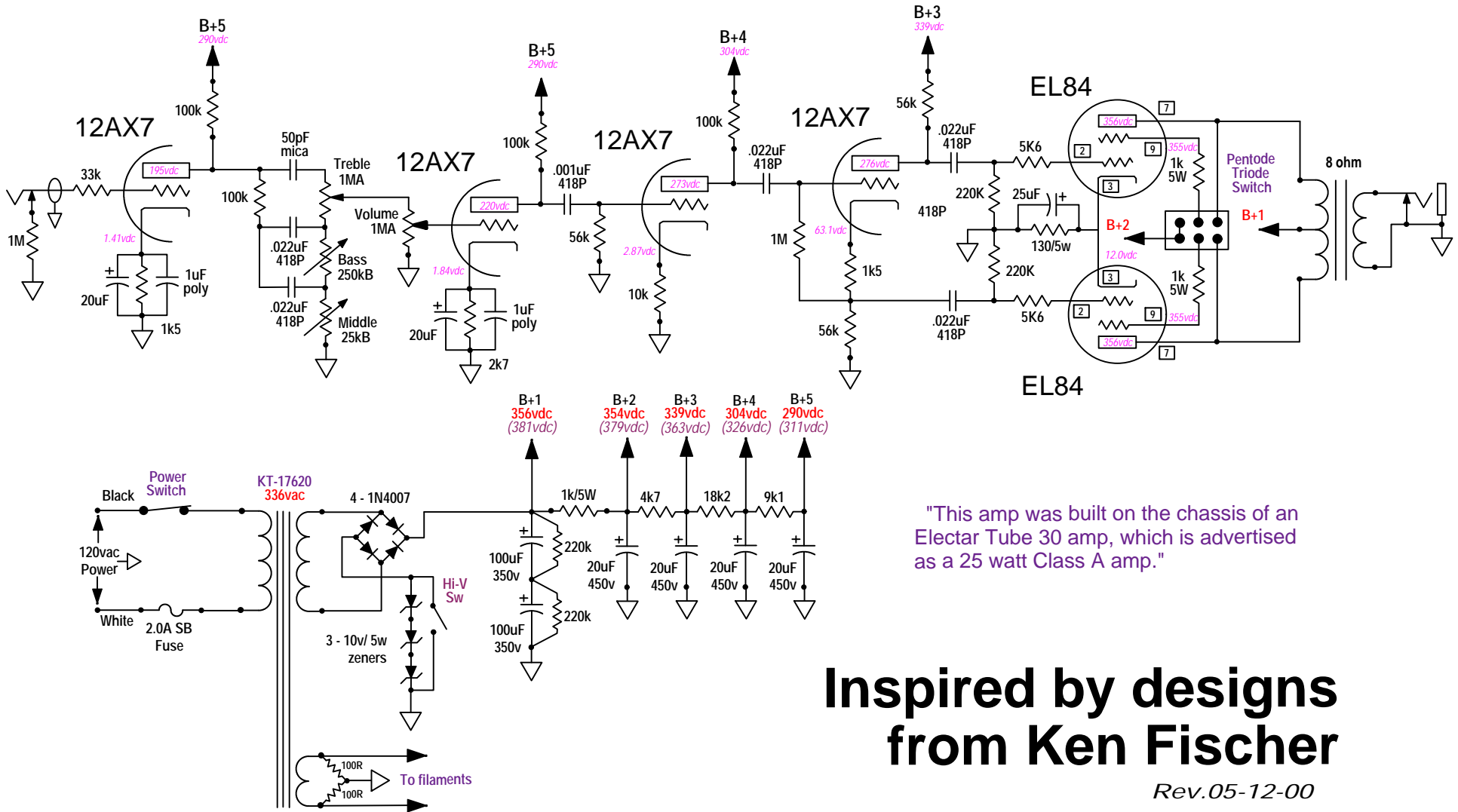

"This amp was built on the chassis of an Electar Tube 30 amp, which is advertised as a 25 watt Class A amp."

Inspired by designs from Ken Fischer

Rev.05-12-00

Trainwreck Blues Express Version A5b

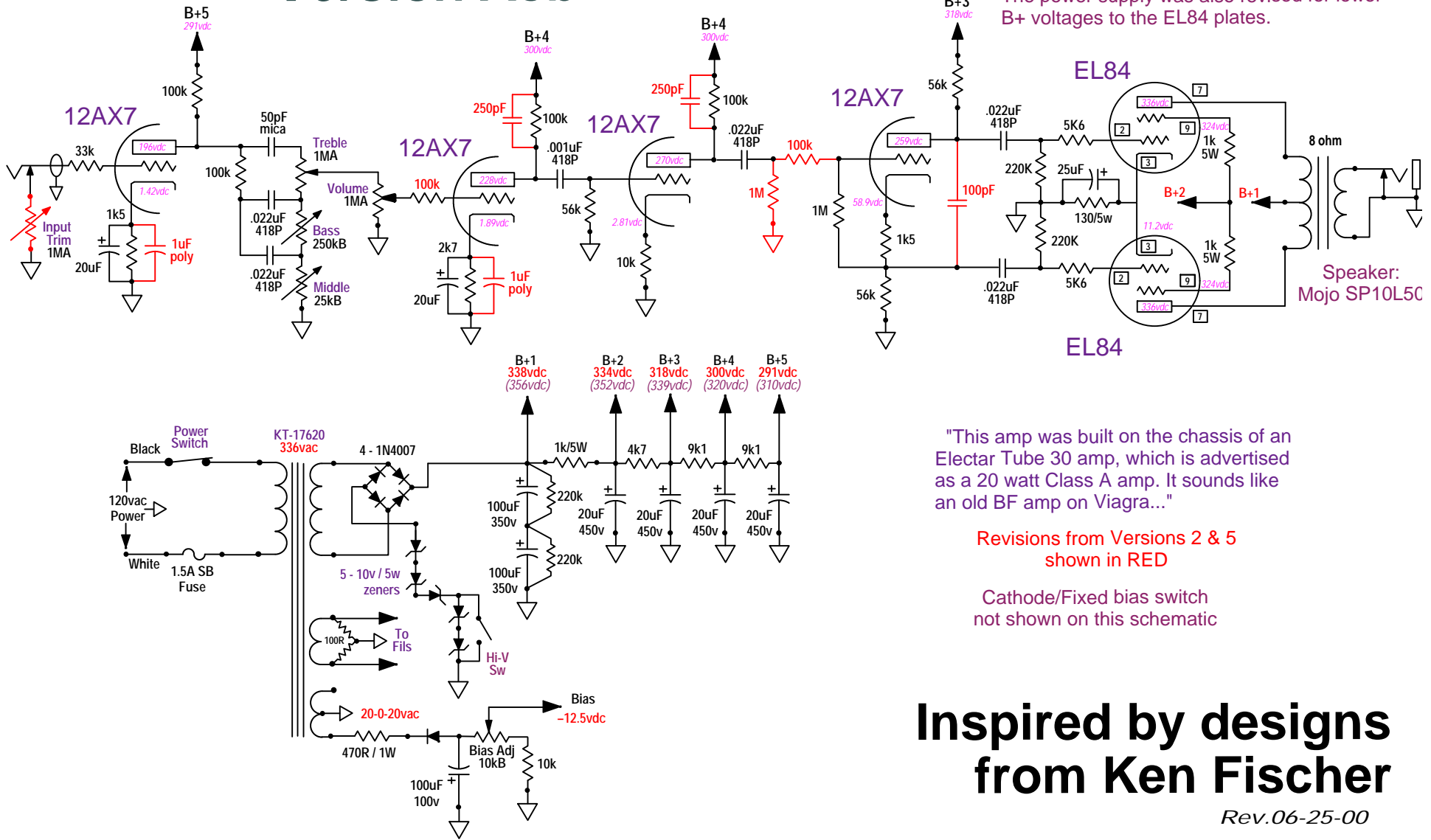

This revision reduced the signal level and treble response in the preamp for a smoother sound in both cathode and fixed bias modes. The power supply was also revised for lower B+ voltages to the EL84 plates.

"This amp was built on the chassis of an Electar Tube 30 amp, which is advertised as a 20 watt Class A amp. It sounds like an old BF amp on Viagra..."

Revisions from Versions 2 & 5 shown in RED

Cathode/Fixed bias switch not shown on this schematic

Inspired by designs from Ken Fischer

Rev.06-25-00

Trainwreck Blues Express Version A5c

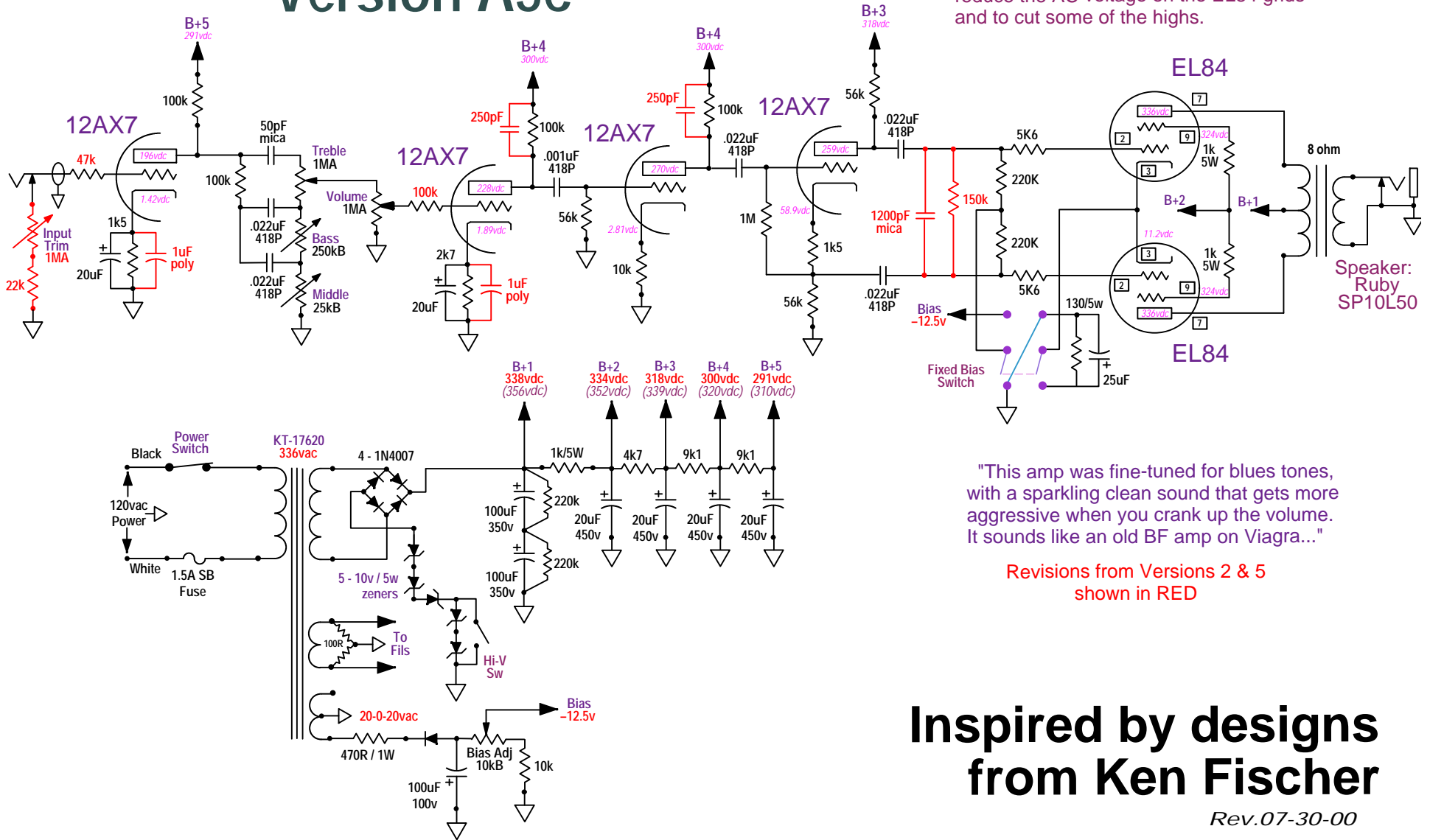

This variation uses a crossline 150k/1200pF RC network after the PI coupling caps to reduce the AC voltage on the EL84 grids and to cut some of the highs.

"This amp was fine-tuned for blues tones, with a sparkling clean sound that gets more aggressive when you crank up the volume. It sounds like an old BF amp on Viagra..."

Revisions from Versions 2 & 5 shown in RED

Inspired by designs from Ken Fischer

Rev.07-30-00

Trainwreck Blues Express Version A5d

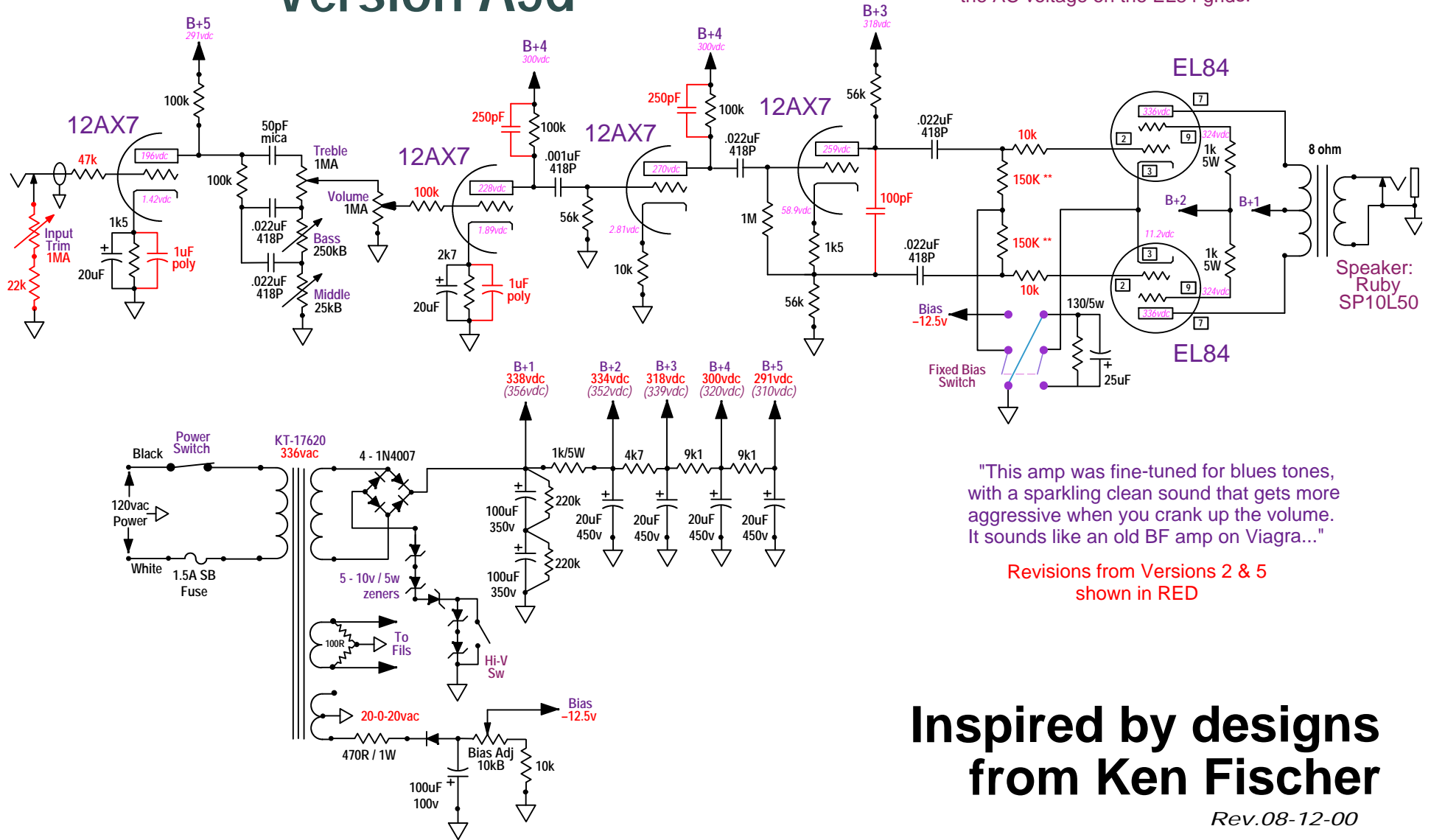

This variation uses 150k ** grid load resistors (instead of 220k) to reduce the AC voltage on the EL84 grids.

"This amp was fine-tuned for blues tones, with a sparkling clean sound that gets more aggressive when you crank up the volume. It sounds like an old BF amp on Viagra..."

Revisions from Versions 2 & 5 shown in RED

Inspired by designs from Ken Fischer

Rev.08-12-00

Trainwreck Blues Express Version A5e

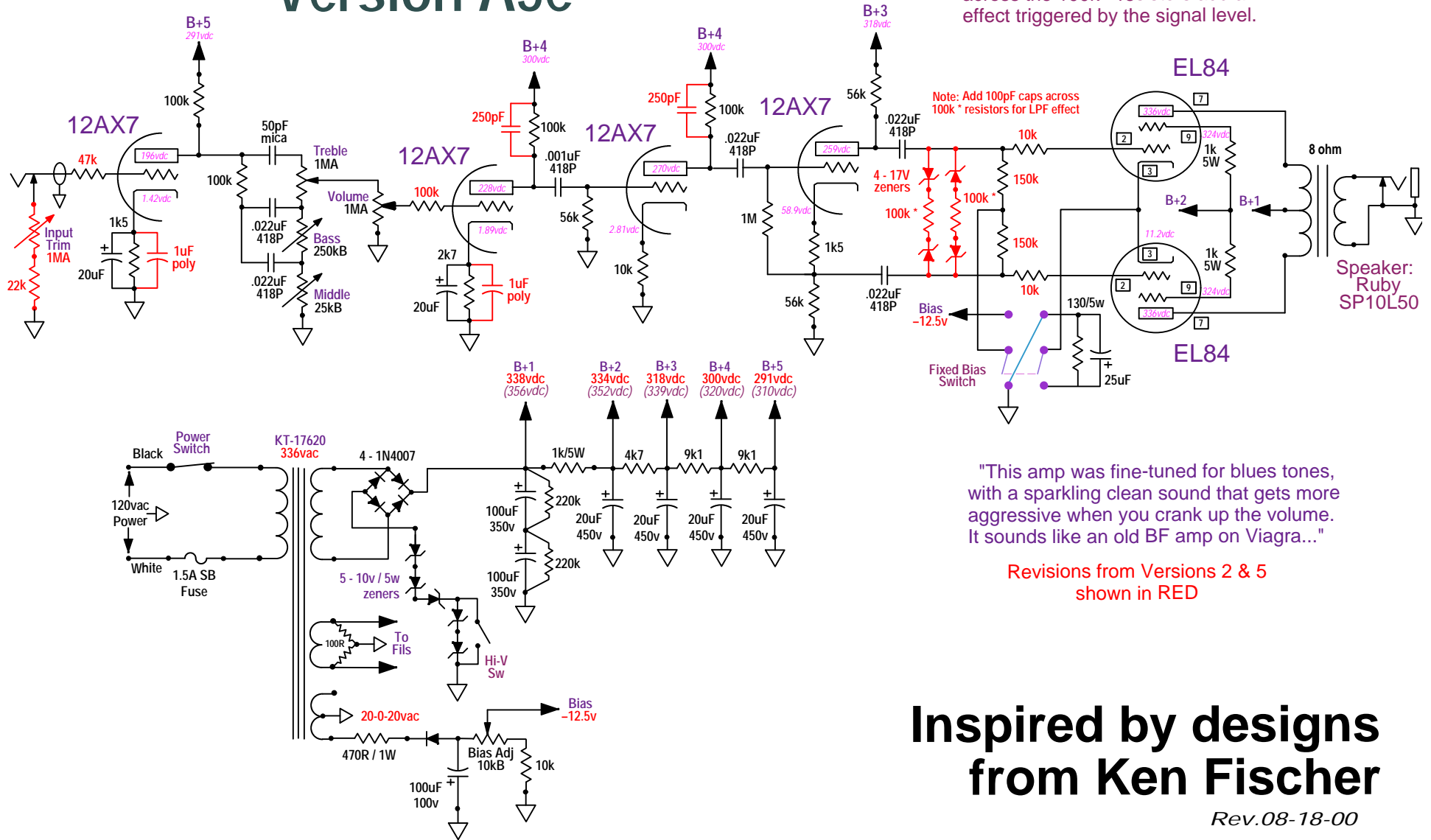

This variation uses zeners across the EL84 grid stoppers to limit the AC voltage on the grids. The optional 100pF caps across the 100k * resistors add an LPF effect triggered by the signal level.

"This amp was fine-tuned for blues tones, with a sparkling clean sound that gets more aggressive when you crank up the volume. It sounds like an old BF amp on Viagra..."

Revisions from Versions 2 & 5 shown in RED

Inspired by designs from Ken Fischer

Rev.08-18-00

Trainwreck Blues Express Version A5f

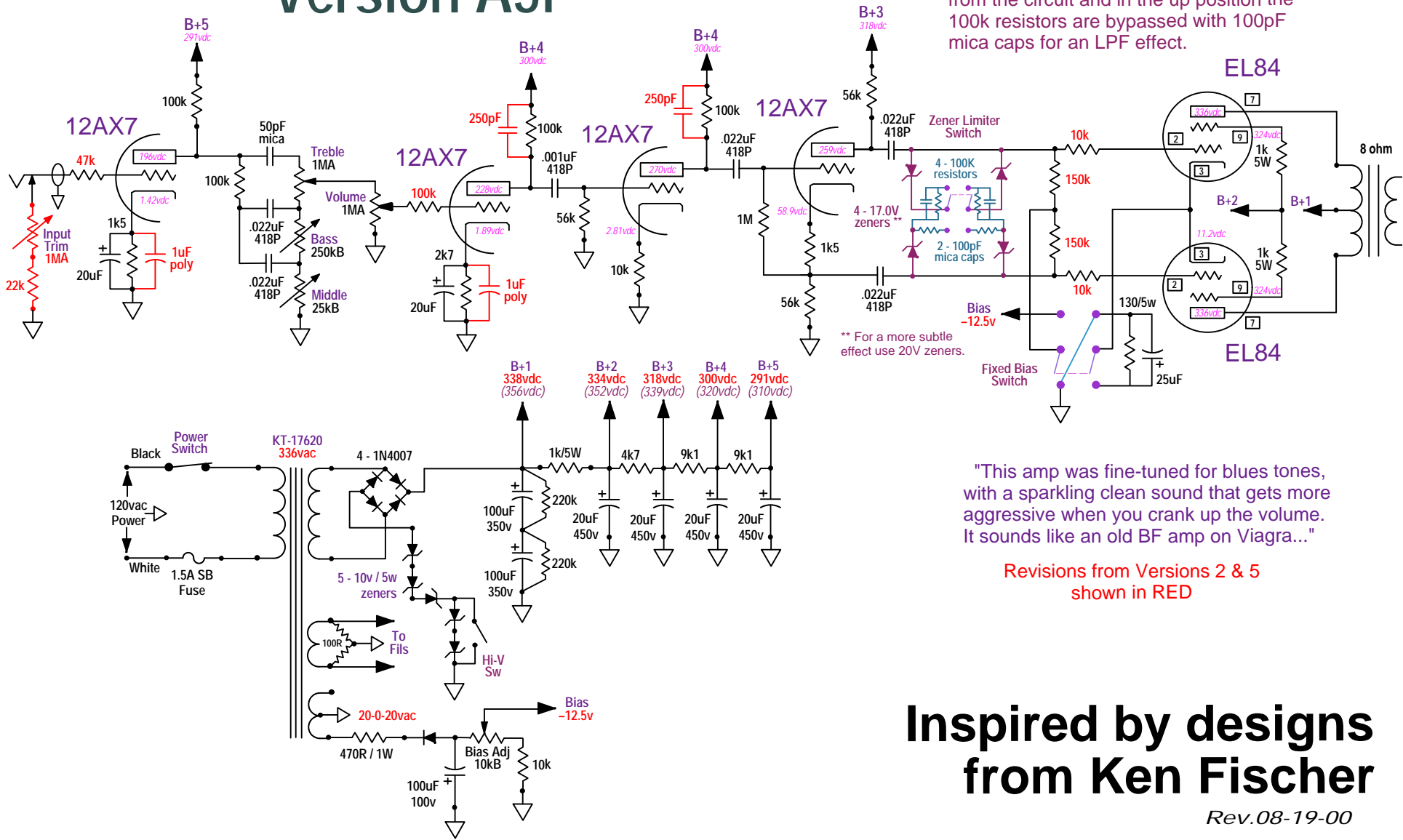

This variation adds a switch to the zener limiting circuit from version A5e. In the center position the zeners are removed from the circuit and in the up position the 100k resistors are bypassed with 100pF mica caps for an LPF effect.

"This amp was fine-tuned for blues tones, with a sparkling clean sound that gets more aggressive when you crank up the volume. It sounds like an old BF amp on Viagra..."

Revisions from Versions 2 & 5 shown in RED

Inspired by designs from Ken Fischer

Rev.08-19-00

Trainwreck Blues Express Version A5g

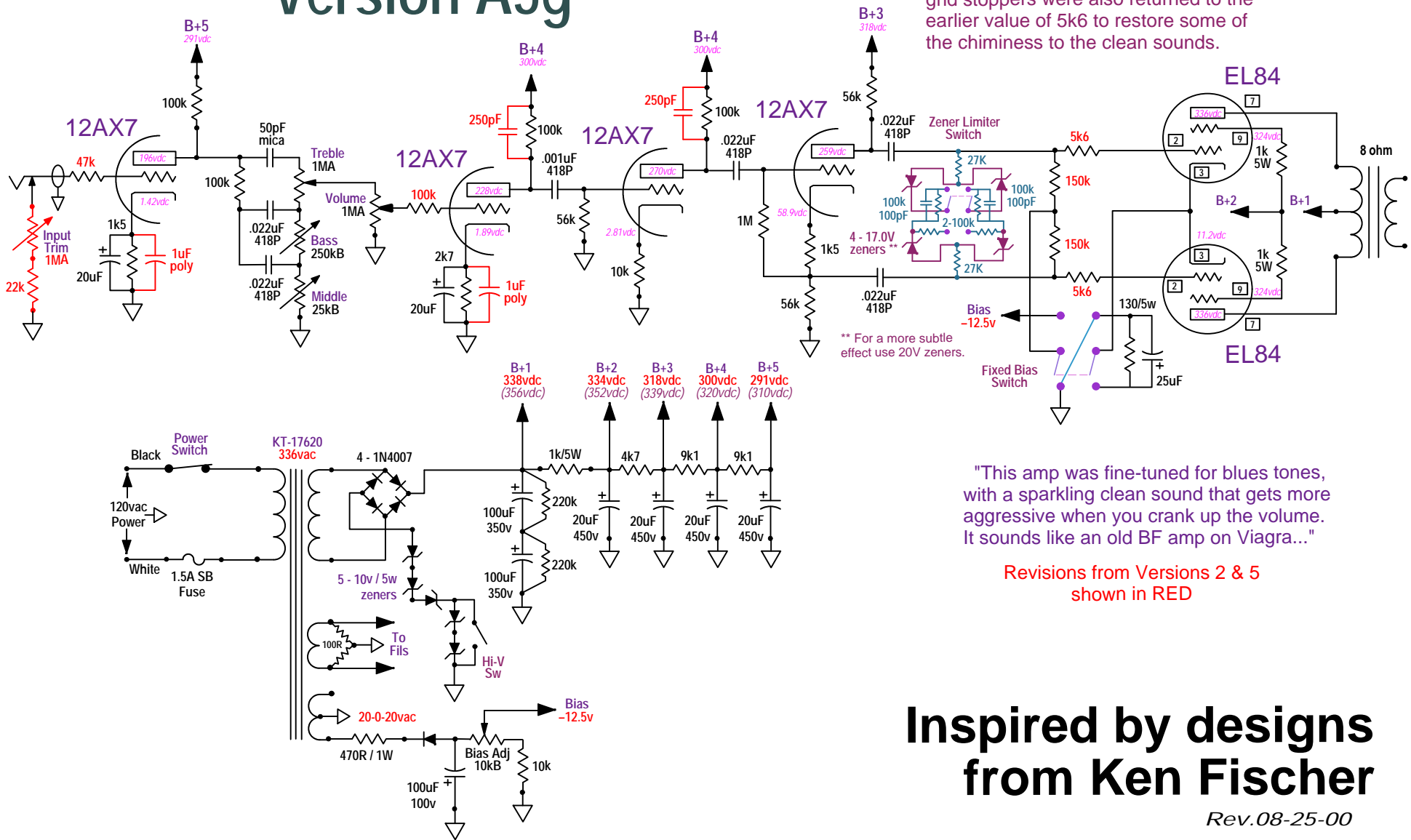

This variation adds two 27k resistors in series with the zener limiting circuit to make the effect more subtle. The EL84 grid stoppers were also returned to the earlier value of 5k6 to restore some of the chiminess to the clean sounds.

"This amp was fine-tuned for blues tones, with a sparkling clean sound that gets more aggressive when you crank up the volume. It sounds like an old BF amp on Viagra..."

Revisions from Versions 2 & 5 shown in RED

Inspired by designs from Ken Fischer

Rev.08-25-00

The Blues Express Version A5h

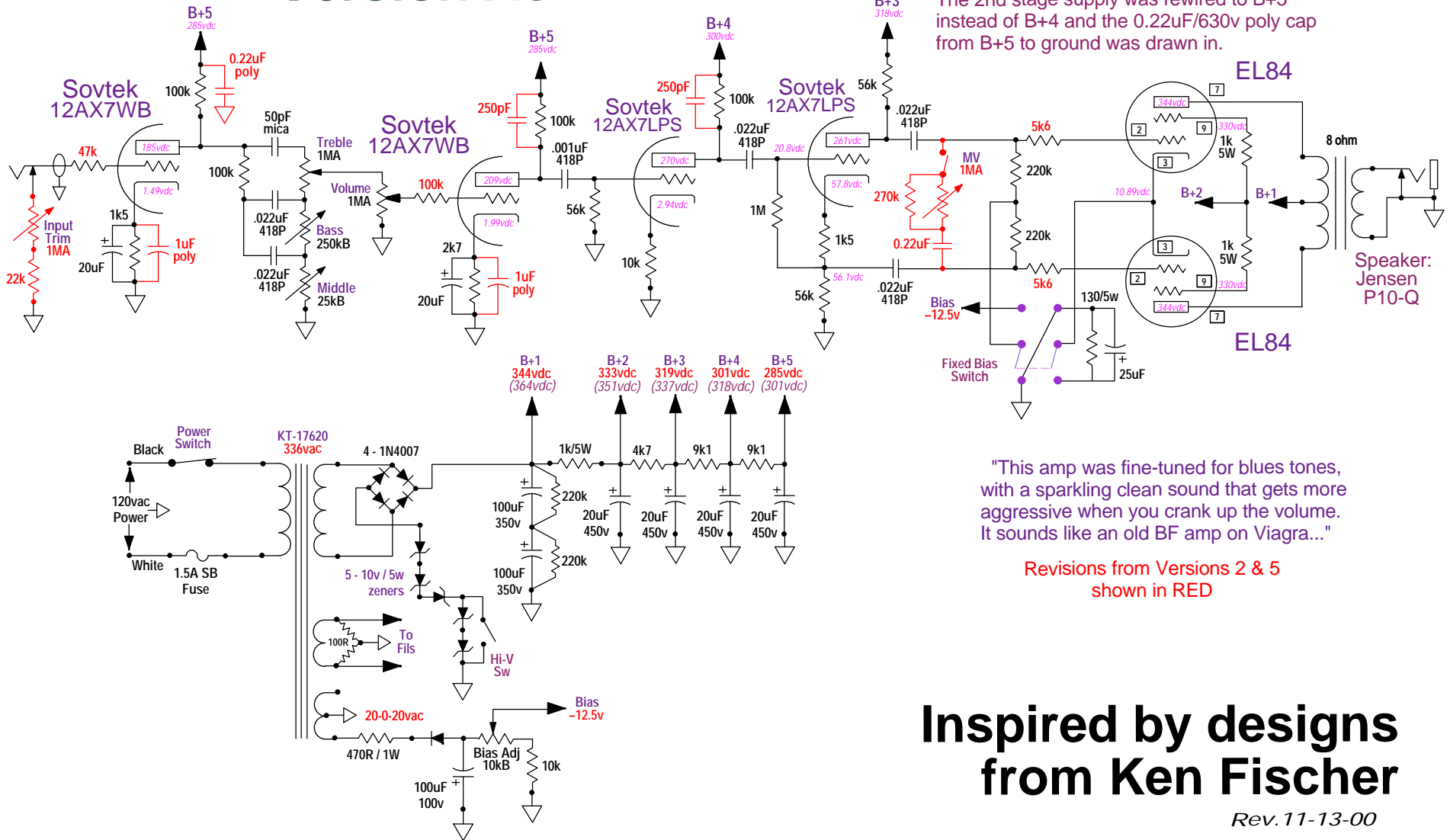

This is the final version of the Blues Express amp. The zener limiting circuit was removed and a modified cross-line MV was installed in its place. The bias/grid load resistors were returned to their original value of 220k. The 2nd stage supply was rewired to B+5 instead of B+4 and the 0.22uF/630v poly cap from B+5 to ground was drawn in.

"This amp was fine-tuned for blues tones, with a sparkling clean sound that gets more aggressive when you crank up the volume. It sounds like an old BF amp on Viagra..."

Revisions from Versions 2 & 5 shown in RED

Inspired by designs from Ken Fischer

Rev. 11-13-00