

101F Vacuum Tube

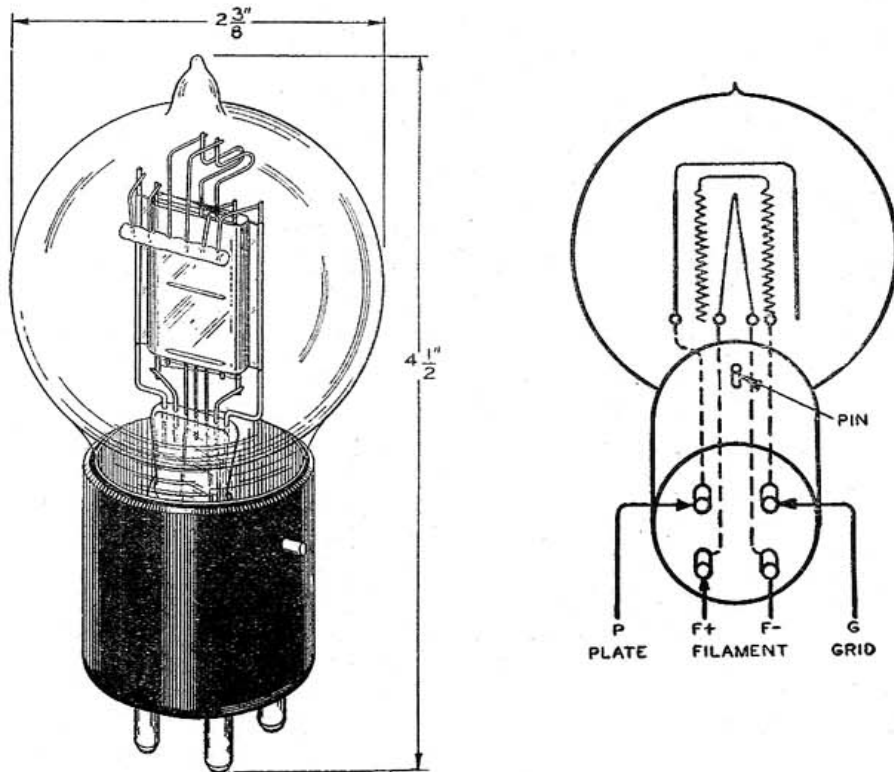

Classification

The No. 101F Vacuum Tube is a three-element filamentary type tube for use where small amounts of output power are required.

Base and Socket

The No. 101F Vacuum Tube employs a four-prong bayonet pin type base suitable for use in a Western Electric No. 100L (front panel mounting), No. 100R (rear panel mounting), or similar type socket.

Rating and Characteristic Data

Filament Current.....				.50 Ampere
Filament Voltage.....				4.1 Volts
Plate Voltage.....	130	130	160	190 Max.
Grid Voltage.....	-8	-8	-12	-16
Average Plate Current—Milliamperes.....	6.0	6.0	6.7	7.5
Average Amplification Factor.....	6.5	6.5	6.5	6.5
Average Plate Resistance—Ohms.....	5900	5900	5600	5400
*Average Power Output—Milliwatts.....	60	55	135	240
Second Harmonic—% of Fundamental.....	5	2	3	4
Third Harmonic—% of Fundamental.....	0.5	0.2	0.3	0.5
Load Resistance—Ohms.....	5900	11800	11200	10800

*Input in peak values is equal to grid voltage.

Approximate Direct Interelectrode Capacities (measured without socket)

Plate to Grid.....	5.9 MMF
Plate to Filament.....	3.7 MMF
Grid to Filament.....	5.2 MMF

Average Static Characteristics

The accompanying curves give the average static characteristics of the No. 101F Vacuum Tube.

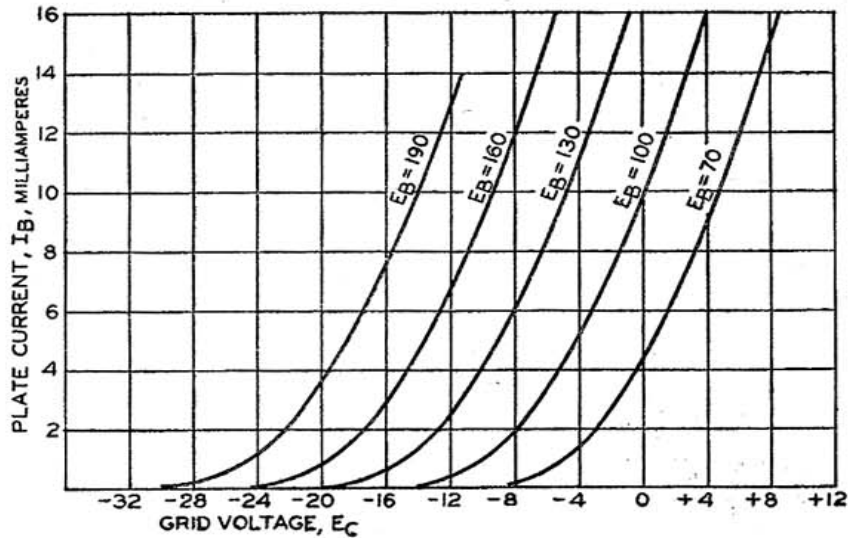

General Features

The No. 101F Vacuum Tube was designed for use where a very long life is essential. This makes it particularly suitable for applications where continuous service is desired. The microphonic response of this tube is low.

The electrical characteristics are such that moderate power outputs are obtainable with small plate currents and with plate voltage under 200 volts.

The characteristics are similar to those of the No. 101D, however, the No. 101F operates at a filament current of 0.5 instead of 1.0 ampere.