



4-POLE VOLTAGE CONTROLLED FILTER

DESCRIPTION

The SSM2044 is a low cost 4-pole voltage controlled filter whose design has been optimized for use as an electronic music lowpass filter. On-chip voltage control of resonance allows direct and easy interfacing with programmers and controllers. A novel filtering technique* provides extended control range, low noise and high control rejection for "pop"-free performance. The filter can also be used as a low distortion sinewave oscillator. No external ladder network is required making the device a real cost and space saver in polyphonic applications.

FEATURES

- Low Cost
- High Control Rejection (36db typical for 1000 to 1 sweep)
- $\pm 18V$ to $\pm 5V$ Supplies
- Minimum External Parts Count
- Stable Resonance Over Frequency Sweep
- No Op Amp Required Between Output and VCA
- 90db Dynamic Range
- 10,000 to 1 Minimum Sweep Range
- On-Chip Resonance Control
- Differential Signal Inputs

*U.S. PATENT # 4,404,529

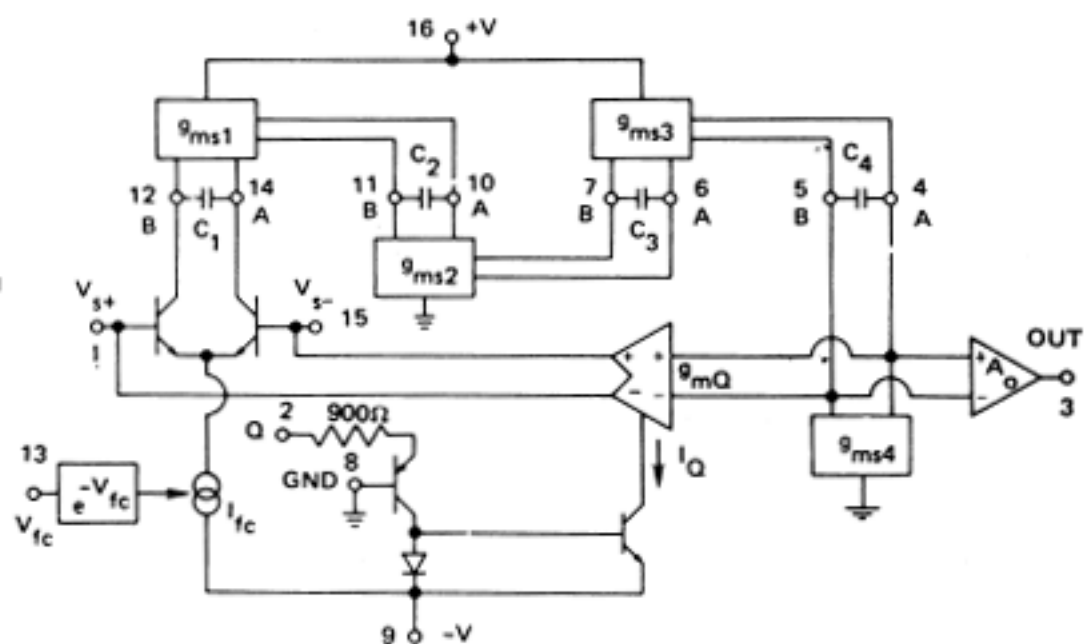
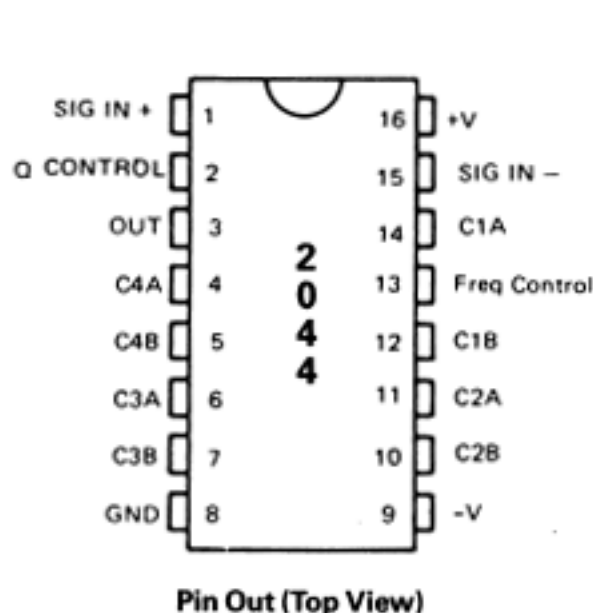

@ $V_s = \pm 15$ and $T_A = 25^\circ\text{C}$ -55°C to $+125^\circ\text{C}$ 0°C to $+70^\circ\text{C}$

PARAMETER	MIN	TYP	MAX	UNITS	CONDITIONS
Positive Supply Range	+5	+15	+18	V	$V_{FC} = \text{GND}$ $V_{FC} = \text{GND}$
Negative Supply Range	-5	-15	-18	V	
Positive Supply Current	1.0	1.4	2.0	mA	
Negative Supply Current	4.5	6.2	8.0	mA	
Frequency Control Range	10,000:1	50,000:1	—		$V_{s^+} = V_{s^-} = \text{GND}$ $-90\text{mV} \leq V_{FC} \leq +90\text{mV}$ $V_{s^+} = V_{s^-} = V_{FC} = \text{GND}$ Untrimmed
Frequency Control Feedthrough	—	-36db	-26db		
Output Offset $I_O/I_{O\text{Max}}$		0.05	0.2		
Frequency Control Offset f/f_{nom}	0.6	1	1.5		
Q Control Input Impedance	675	900	1200	Ω	$V_{QC} \geq 0.7\text{V}$ $-90\text{mV} \leq V_{fc} \leq +90\text{mV}$
Q Current at Oscillation	450	500	550	μA	
Q Control Feedthrough	—	-30db	-20db		
Q Control Threshold Voltage	400	500		mV	
Max Available Control Current	1.25	1.7	2.2	mA	$V_{\text{PIN } 13} = -120\text{mV}$ RE: 30mV_{pp} (Pin 1 or 15)
Freq. Control Input Range	-120	—	+180	mV	
Max Output Signal Current $I_{O\text{Max}}$	± 300	± 400	± 520	μA	
Signal to Noise	—	70db	—		

Figure 1 below shows the amplitude vs frequency response for the 2044 at different Q or resonance settings. The solid curve is the response of the filter at minimum Q which is a gradual rolloff approaching -24db/octave at high frequencies. As Q is increased, low frequency components are suppressed and components near the cutoff frequency are emphasized. For all Q settings below oscillation the final rolloff at high frequencies is -24db/octave. At high Q settings the filter will oscillate with a pure sinewave at the cutoff frequency. This waveform can be used as a tone source if the design procedures given below are followed.

The second figure below shows Q or resonance of a four-pole lowpass filter as a function of feedback or Q control current. The function changes very slowly with control current at the low end but increases very rapidly as oscillation is approached. In general, this type of filter causes a problem when designing a Q panel control that has the right feel. The optimum control pot would have the reciprocal of this response; a requirement approximated by an audio pot connected in reverse of its normal configuration: a "reverse audio" pot. To obtain maximum resolution from the pot, a resistor that is one-third of its value can be connected in series to ground. This will discard the lower 25% of the Q response curve where almost nothing happens. Figure 4.

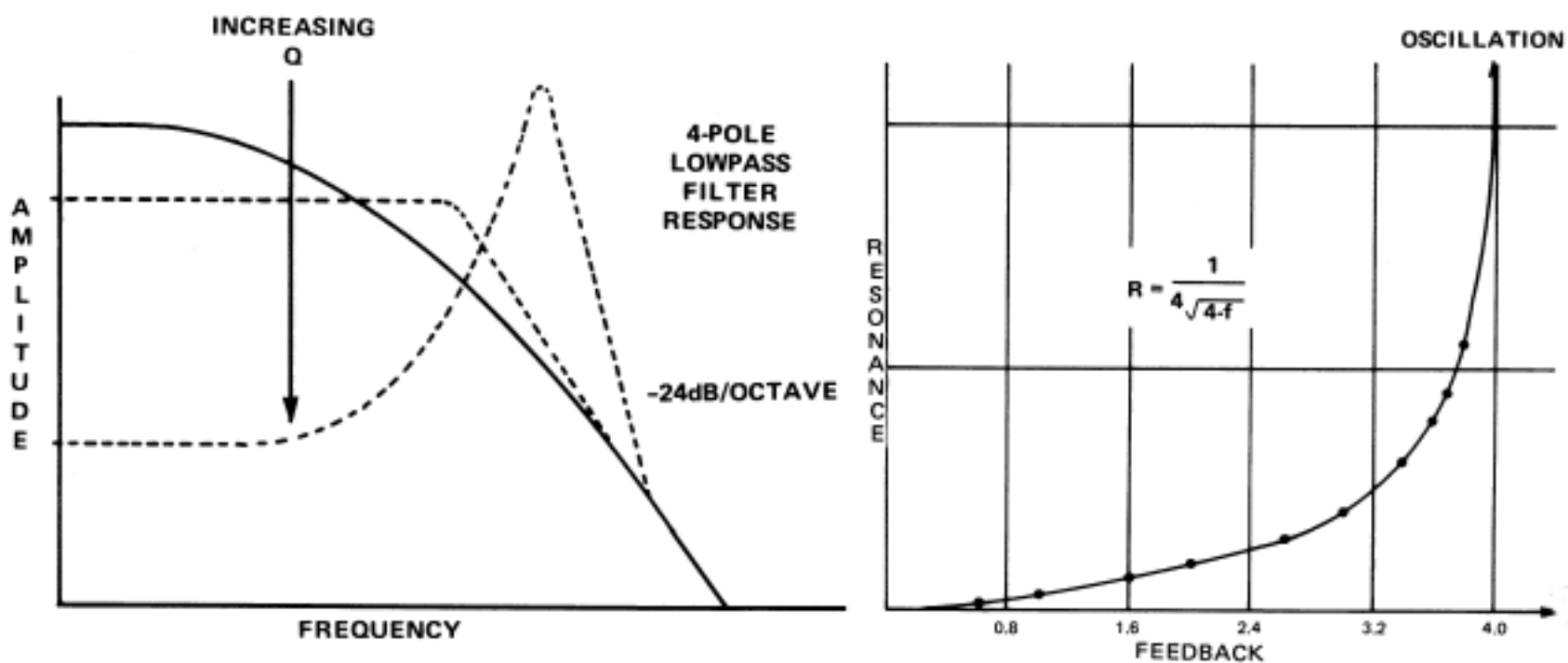

Figure 1

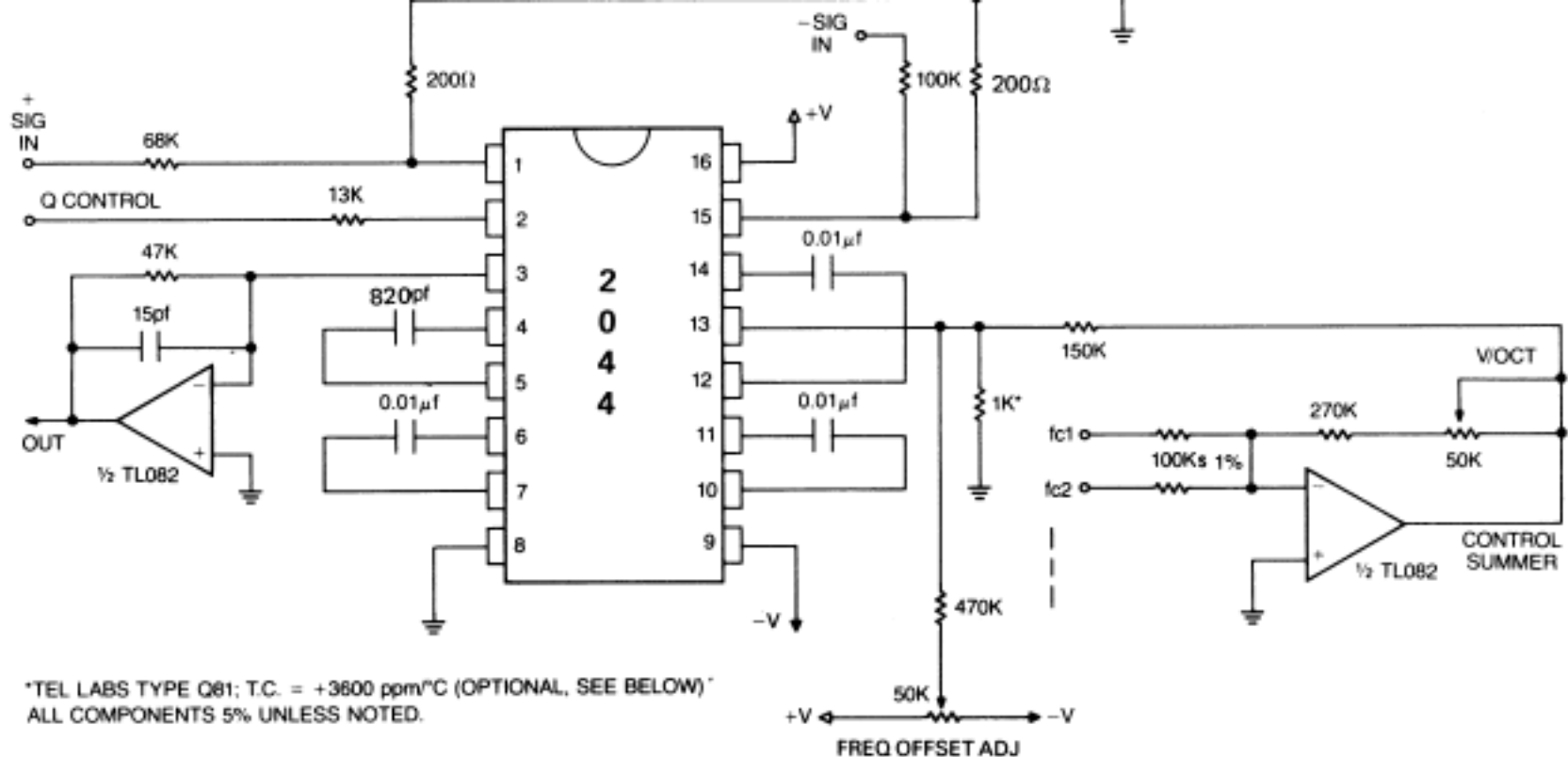

Figure 3—Typical Connection

The figure above shows the typical connection of the 2044 as a four-pole lowpass electronic music filter. The differential signal inputs will accept any signal(s) up to $\pm 18V$ peak-to-peak. If two oscillators are used in a voice, the output of the second should go to the opposite filter input from the first with a 3db signal level difference. This can be accomplished by scaling the input attenuators as shown, thus preventing cancellation as the oscillators phase with each other.

The sense of the Q control is from GND up with minimum resonance at GND. Oscillation will occur when the current into the Q pin reaches approximately $425 \mu A$. With the input resistor shown this corresponds to +7.5V.

The control summer adds the voltages from various control sources such as the f_c panel control, transient generator, LFO etc. Any number of signals can be summed by applying them through resistors to the summing node of the op amp. The frequency offset adjust is required in polyphonic and programmable systems to make the filter(s) sound the same for an identical input control voltage. For best control rejection, the control summer and input attenuator should be designed so that the maximum swing at the 2044 control pin corresponds to the extremes of the intended sweep range when the control summer is driven to the supplies. With the values shown, one will obtain $\pm 90mV$ at the input pin which corresponds to a 1000-to-1 sweep range for $\pm 15V$ supplies.

The V/octave trim and the Tel Labs temperature compensating resistor are required in applications where the filter has to produce accurate musical intervals when in oscillation. If this is not necessary the control op amp feedback network and the Tel Labs resistor can be replaced by 1% 300K and 1 K resistors respectively.

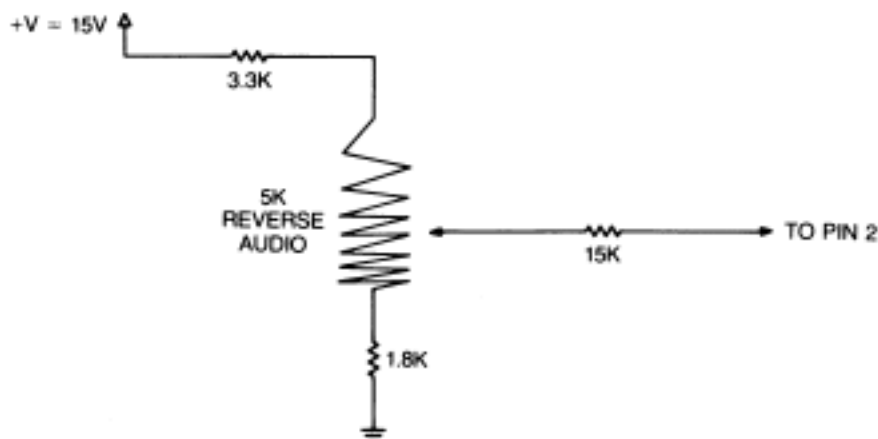

Figure 4

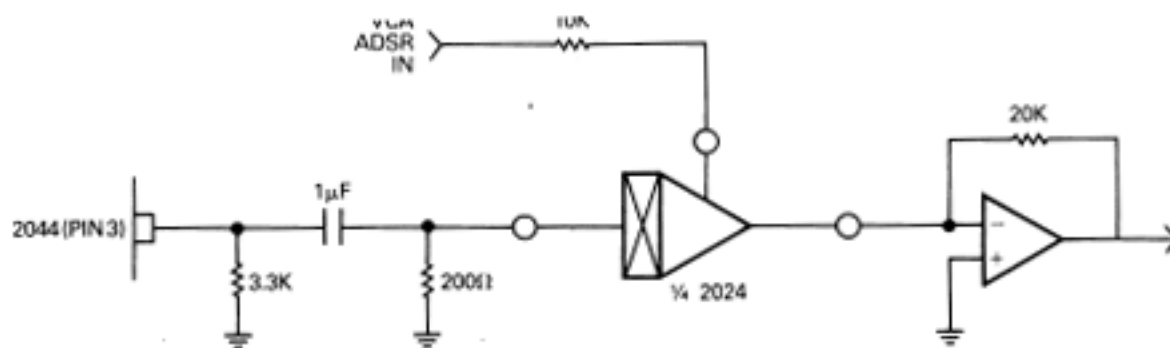

Figure 5: 2044 to VCA Interface

Figure 5 above shows a circuit that will drive a VCA input from the output of the 2044 without an intervening op amp. The 1µF cap provides a D.C. block so that the 2044 offset will not affect the D.C. balance of the 2024 VCA. With this connection, an offset adjustment is not required to guarantee a worst case 30db VCA control rejection.

The SSM 2024 QUAD VCA is an excellent companion product to the 2044. Its channel specs offer excellent performance as voltage controlled waveform and control mixers as well as a voicing VCA.

Solid State Micro



Technology
for Music